

PROGRAMMABLE CONTROLLERS



MELSEC iQ-F
series



MELSEC iQ-F FX5U Series
User's Manual [Hardware]

SAFETY PRECAUTIONS

(Read these precautions before use.)

Before using this product, please read this manual and the relevant manuals introduced in this manual carefully and pay full attention to safety in order to handle the product correctly.

This manual classifies the safety precautions into two categories: [ WARNING] and [ CAUTION].

 WARNING	Indicates that incorrect handling may cause hazardous conditions, resulting in death or severe injury.
 CAUTION	Indicates that incorrect handling may cause hazardous conditions, resulting in minor or moderate injury or property damage.

Depending on the circumstances, procedures indicated by [ CAUTION] may also cause severe injury.

It is important to follow all precautions for personal safety.

Store this manual in a safe place so that it can be read whenever necessary. Always forward it to the end user.

[DESIGN PRECAUTIONS]

WARNING

- Make sure to set up the following safety circuits outside the PLC to ensure safe system operation even during external power supply problems or PLC failure. Otherwise, malfunctions may cause serious accidents.
 - Most importantly, set up the following: an emergency stop circuit, a protection circuit, an interlock circuit for opposite movements (such as forward vs. reverse rotation), and an interlock circuit to prevent damage to the equipment at the upper and lower positioning limits.
 - Note that when the CPU module detects an error, such as a watchdog timer error, during self-diagnosis, all outputs are turned off. Also, when an error that cannot be detected by the CPU module occurs in an input/output control block, output control may be disabled. External circuits and mechanisms should be designed to ensure safe machine operation in such a case.
 - Note that the output current of the 24 V DC service power supply varies depending on the model and the absence/presence of extension modules. If an overload occurs, the voltage automatically drops, inputs in the PLC are disabled, and all outputs are turned off. External circuits and mechanisms should be designed to ensure safe machine operation in such a case.
 - Note that when an error occurs in a relay or transistor of an output circuit, the output might stay on or off. For output signals that may lead to serious accidents, external circuits and mechanisms should be designed to ensure safe machine operation.
 - Construct an interlock circuit in the program to ensure safe operation for the whole system when executing control (for data change) of the PLC in operation.

Read the manual thoroughly and ensure complete safety before executing other controls (for program change, parameter change, forced output and operation status change) of the PLC in operation. Otherwise, the machine may be damaged and accidents may occur due to erroneous operations.
 - In an output circuit, when a load current exceeding the current rating or an overcurrent caused by a load short-circuit flows for a long time, it may cause smoke and fire. To prevent this, configure an external safety circuit, such as a fuse.
 - For the operating status of each station after a communication failure of the network, refer to relevant manuals for the network. Incorrect output or malfunction may result in an accident.
-

[DESIGN PRECAUTIONS]

CAUTION

- When an inductive load such as a lamp, heater, or solenoid valve is controlled, a large current (approximately ten times greater than normal) may flow when the output is turned from off to on. Take proper measures so that the flowing current does not exceed the value corresponding to the maximum load specification of the resistance load.
 - After the CPU module is powered on or is reset, the time taken to enter the RUN status varies depending on the system configuration, parameter settings, and/or program size.
Design circuits so that the entire system will always operate safely, regardless of this variation in time.
 - Simultaneously turn on and off the power supplies of the CPU module and extension modules.
 - If a long-time power failure or an abnormal voltage drop occurs, the PLC stops, and output is turned off. When the power supply is restored, it will automatically restart (when the RUN/STOP/RESET switch is on RUN).
-

[INSTALLATION PRECAUTIONS]

WARNING

- Make sure to cut off all phases of the power supply externally before attempting installation or wiring work. Failure to do so may cause electric shock or damage to the product.
 - Use the product within the generic environment specifications described in  Page 19 Generic Specifications of this manual.
Never use the product in areas with excessive dust, oily smoke, conductive dusts, corrosive gas (salt air, Cl₂, H₂S, SO₂ or NO₂), flammable gas, vibration or impacts, or expose it to high temperature, condensation, or rain and wind.
If the product is used in such conditions, electric shock, fire, malfunctions, deterioration or damage may occur.
-

[INSTALLATION PRECAUTIONS]

CAUTION

- Do not touch the conductive parts of the product directly. Doing so may cause device failures or malfunctions.
 - When drilling screw holes or wiring, make sure that cutting and wiring debris do not enter the ventilation slits of the PLC. Failure to do so may cause fire, equipment failures or malfunctions.
 - For product supplied together with a dust proof sheet, the sheet should be affixed to the ventilation slits before the installation and wiring work in order to block foreign objects such as cutting and wiring debris.
However, when the installation work is completed, make sure to remove the sheet to provide adequate ventilation. Failure to do so may cause fire, equipment failures or malfunctions.
 - Install the product on a flat surface. If the mounting surface is rough, undue force will be applied to the PC board, thereby causing nonconformities.
 - Install the product securely using a DIN rail or mounting screws.
 - Connect the expansion board and expansion adapter securely to their designated connectors. Loose connections may cause malfunctions.
 - Make sure to affix the expansion board with tapping screws. Tightening torque should follow the specifications in the manual. If the screws are tightened outside of the specified torque range, poor connections may cause malfunctions.
 - Work carefully when using a screwdriver during product installation. Failure to do so may cause damage to the product or accidents.
 - Connect the extension cables, peripheral device cables, input/output cables and battery connecting cable securely to their designated connectors. Loose connections may cause malfunctions.
 - When using an SD memory card, insert it into the SD memory card slot. Check that it is inserted completely. Poor contact may cause malfunction.
 - Turn off the power to the PLC before attaching or detaching the following devices. Failure to do so may cause device failures or malfunctions.
 - Peripheral devices, expansion board and expansion adapter
 - Extension modules and bus conversion module
 - Battery
-

[WIRING PRECAUTIONS]

WARNING

- Make sure to cut off all phases of the power supply externally before attempting installation or wiring work. Failure to do so may cause electric shock or damage to the product.
 - Make sure to attach the terminal cover, provided as an accessory, before turning on the power or initiating operation after installation or wiring work. Failure to do so may cause electric shock.
 - The temperature rating of the cable should be 80°C or more.
 - Make sure to wire the screw terminal block in accordance with the following precautions. Failure to do so may cause electric shock, equipment failures, a short-circuit, wire breakage, malfunctions, or damage to the product.
 - Wire terminals should follow the dimensions described in the manual.
 - Tightening torque should follow the specifications in the manual.
 - Tighten the screws using a Phillips-head screwdriver No. 2 (shaft diameter 6 mm (0.24") or less). Make sure that the screwdriver does not touch the partition part of the terminal block.
 - Make sure to wire the terminal block (European type) in accordance with the following precautions. Failure to do so may cause electric shock, equipment failures, a short-circuit, wire breakage, malfunctions, or damage to the product.
 - Wire terminals should follow the dimensions described in the manual.
 - Tightening torque should follow the specifications in the manual.
 - Twist the ends of stranded wires and make sure that there are no loose wires.
 - Do not solder-plate the electric wire ends.
 - Do not connect more than the specified number of wires or electric wires of unspecified size.
 - Affix the electric wires so that neither the terminal block nor the connected parts are directly stressed.
-

[WIRING PRECAUTIONS]

CAUTION

- Do not supply power to the [24+] and [24V] terminals (24 V DC service power supply) on the CPU module or extension modules. Doing so may cause damage to the product.
 - Perform class D grounding (grounding resistance: 100 Ω or less) of the grounding terminal on the CPU module and extension modules with a wire 2 mm² or thicker.
However, do not use common grounding (refer to  Page 79 Grounding) with heavy electrical systems.
 - Connect the power supply wiring to the dedicated terminals described in this manual. If an AC power supply is connected to a DC input/output terminal or DC power supply terminal, the PLC will burn out.
 - Do not wire vacant terminals externally. Doing so may cause damage to the product.
 - Install module so that excessive force will not be applied to terminal blocks, power connectors, I/O connectors, communication connectors, or communication cables. Failure to do so may result in wire damage/breakage or PLC failure.
-

CAUTION

- Make sure to observe the following precautions in order to prevent any damage to the machinery or accidents due to malfunction of the PLC caused by abnormal data written to the PLC due to the effects of noise.
 - Do not bundle the power line, control line and communication cables together with or lay them close to the main circuit, high-voltage line, load line or power line. As a guideline, lay the power line, control line and connection cables at least 100 mm (3.94") away from the main circuit, high-voltage line, load line or power line.
 - Ground the shield of the shield wire or shielded cable at one point on the PLC. However, do not use common grounding with heavy electrical systems.
 - Ground the shield of the analog input/output cable at one point on the signal receiving side. Do not use common grounding with heavy electrical systems.

[STARTUP AND MAINTENANCE PRECAUTIONS]

WARNING

- Do not touch any terminal while the PLC's power is on. Doing so may cause electric shock or malfunctions.
 - Before cleaning or retightening terminals, cut off all phases of the power supply externally. Failure to do so may cause electric shock.
 - Before modifying the program in mid-operation, forcing output, running or stopping the PLC, read through this manual carefully, and ensure complete safety. An operation error may damage the machinery or cause accidents.
 - Do not change the program in the PLC from two or more peripheral equipment devices at the same time. (i.e. from an engineering tool and a GOT) Doing so may cause destruction or malfunction of the PLC program.
 - Use the battery for memory backup in conformance to this manual.
 - Use the battery for the specified purpose only.
 - Connect the battery correctly.
 - Do not charge, disassemble, heat, put in fire, short-circuit, connect reversely, weld, swallow or burn the battery, or apply excessive force (vibration, impact, drop, etc.) to the battery.
 - Do not store or use the battery at high temperatures or expose to direct sunlight.
 - Do not expose to water, bring near fire or touch liquid leakage or other contents directly.
- Incorrect handling of the battery may cause excessive heat, bursting, ignition, liquid leakage or deformation, and lead to injury, fire or failures and malfunction of facilities and other equipment.
-

[STARTUP AND MAINTENANCE PRECAUTIONS]

CAUTION

- Do not disassemble or modify the PLC. Doing so may cause fire, equipment failures, or malfunctions.
*For repair, contact your local Mitsubishi Electric representative.
 - After the first use of the SD memory card, do not insert/remove the memory card more than 500 times. Insertion/removal 500 times or more may cause malfunction.
 - Turn off the power to the PLC before connecting or disconnecting any extension cable. Failure to do so may cause device failures or malfunctions.
 - Turn off the power to the PLC before attaching or detaching the following devices. Failure to do so may cause device failures or malfunctions.
 - Peripheral devices, expansion board and expansion adapter
 - Extension modules and bus conversion module
 - Battery
-

[OPERATION PRECAUTIONS]

CAUTION

- Construct an interlock circuit in the program to ensure safe operation for the whole system when executing control (for data change) of the PLC in operation. Read the manual thoroughly and ensure complete safety before executing other controls (for program change, parameter change, forced output and operation status change) of the PLC in operation. Otherwise, the machine may be damaged and accidents may occur by erroneous operations.
-



[DISPOSAL PRECAUTIONS]

CAUTION

- Please contact a certified electronic waste disposal company for the environmentally safe recycling and disposal of your device.
 - When disposing of batteries, separate them from other waste according to local regulations. For details on the Battery Directive in EU countries, refer to  Page 136 Handling of Batteries and Devices with Built-in Batteries in EU Member States.
-

[TRANSPORTATION PRECAUTIONS]

CAUTION

- When transporting the PLC with the optional battery, turn on the PLC before shipment, confirm that the battery mode is set in PLC parameters and the BAT LED is OFF, and check the battery life. If the PLC is transported with the BAT LED on or the battery exhausted, the battery-backed data may be lost during transportation.
 - The PLC is a precision instrument. During transportation, avoid impacts larger than those specified in the general specifications ( Page 19 Generic Specifications) by using dedicated packaging boxes and shock-absorbing pallettes. Failure to do so may cause failures in the PLC. After transportation, verify operation of the PLC and check for damage of the mounting part, etc.
 - When transporting lithium batteries, follow required transportation regulations. For details on the regulated products, refer to  Page 136 Handling of Batteries and Devices with Built-in Batteries in EU Member States.
 - Fumigants that contain halogen materials such as fluorine, chlorine, bromine, and iodine used for disinfecting and protecting wooden packaging from insects will cause malfunction in Mitsubishi products. Please take necessary precautions to ensure that residual fumigants do not enter the product, or treat packaging with methods other than fumigation (heat method). Additionally, disinfect and protect wood from insects before packing.
-

INTRODUCTION

This manual contains text, diagrams and explanations which will guide the reader in the correct installation, safe use and operation of the FX5U Series Programmable Controllers and should be read and understood before attempting to install or use the module.

Always forward it to the end user.

Regarding use of this product

- This product has been manufactured as a general-purpose part for general industries, and has not been designed or manufactured to be incorporated in a device or system used in purposes related to human life.
- Before using the product for special purposes such as nuclear power, electric power, aerospace, medicine or passenger movement vehicles, consult Mitsubishi Electric.
- This product has been manufactured under strict quality control. However when installing the product where major accidents or losses could occur if the product fails, install appropriate backup or failsafe functions in the system.

Note

- If in doubt at any stage during the installation of the product, always consult a professional electrical engineer who is qualified and trained in the local and national standards. If in doubt about the operation or use, please consult the nearest Mitsubishi Electric representative.
- Since the examples indicated by this manual, technical bulletin, catalog, etc. are used as a reference, please use it after confirming the function and safety of the equipment and system. Mitsubishi Electric will accept no responsibility for actual use of the product based on these illustrative examples.
- This manual content, specification etc. may be changed, without a notice, for improvement.
- The information in this manual has been carefully checked and is believed to be accurate; however, if you notice a doubtful point, an error, etc., please contact the nearest Mitsubishi Electric representative. When doing so, please provide the manual number given at the end of this manual.

MEMO

CONTENTS

SAFETY PRECAUTIONS	1
INTRODUCTION	8
RELEVANT MANUALS	14
TERMS	14
CHAPTER 1 OUTLINE	16
1.1 Part Names	16
Front panel	16
Side	18
CHAPTER 2 SPECIFICATIONS	19
2.1 Generic Specifications	19
2.2 Power Supply Specifications	20
AC power supply	20
2.3 Input Specifications	21
24 V DC Input (sink/source)	21
2.4 Output Specifications	23
Relay output	23
Transistor output	24
2.5 Input/Output Derating Curve	24
2.6 Performance Specifications	25
2.7 Built-in Analog Specifications	27
Analog input	27
Analog output	27
2.8 Communication Specifications	28
Built-in Ethernet communication	28
Built-in RS-485 communication	28
2.9 External Dimensions	29
FX5U-32M□	29
FX5U-64M□, FX5U-80M□	29
2.10 Terminal Layout	30
CHAPTER 3 PRODUCT LIST	33
3.1 Overall Configuration	33
3.2 CPU Module	34
3.3 I/O Module	35
3.4 Intelligent Function Module	36
FX5 series	36
FX3 series	36
3.5 Expansion Board	37
3.6 Expansion Adapter	37
3.7 Extension Power Supply Module	38
FX5 series	38
FX3 series	38
3.8 Bus Conversion Module	38
3.9 SD Memory Card	38
3.10 Battery	38
3.11 Communication Cable	39

3.12	Engineering Tool	39
CHAPTER 4 SYSTEM CONFIGURATION		40
4.1	Rules of System Configuration	41
4.2	Limitations on the Number of Connected Extension Devices	43
	Number of connected expansion boards	43
	Number of connected expansion adapters	43
	Number of connected extension modules	43
4.3	Limitation on the Number of Input/Output Points	46
	Total number of I/O points and remote I/O points	46
	Calculation of number of input/output points	47
	Calculation of number of remote I/O points	48
4.4	Limitation on Current Consumption	49
	Power supply check from the CPU module (current consumption calculation)	49
	Power supply check from the powered input/output module (current consumption calculation)	50
	Power supply check from extension power supply module (current consumption calculation)	52
4.5	Rules of System Configuration and Examples of Reconfiguration	54
	System configuration example	54
	System reconfiguration example	58
4.6	Numbers and Assignment in System	63
	Module input/output number	63
	Module number of Extension modules	63
CHAPTER 5 INSTALLATION		64
5.1	Installation Location	64
	Installation location in enclosure	64
	Spaces in enclosure	64
	Layout in enclosure	64
5.2	Examination for Installation Method in Enclosure	65
5.3	Procedures for Installing on and Detaching from DIN Rail	66
	Preparation for installation	66
	Installation of CPU module	66
	Installation of extension module	67
	Removal of CPU module	67
5.4	Procedures for Installing Directly (with M4 Screws)	68
	Hole pitches for direct mounting	68
	Hole pitches when extension module connected	70
	Installation of CPU module	70
	Installation of extension module	71
5.5	Connection Methods for CPU Module and Extension Devices	72
	Connection of extension devices	72
	Connection method A - connection of an expansion board	72
	Connection method B - connection of an expansion adapter	73
	Connection method C - connection of an extension module to the CPU module	73
	Connection method D - connection between extension modules	74
	Connection method E - connection of an extension module to the bus conversion module	74
CHAPTER 6 WIRING		75
6.1	Wiring Preparations	75
	Wiring procedure	75

	Removal and installation of removable terminal block	76
6.2	Cable Connecting Procedure	77
	Screw terminal block	77
	European-type terminal block	78
6.3	Grounding	79
6.4	Power Supply Wiring	80
	Examples of AC power supply wiring	80
6.5	Input Wiring	84
	24 V DC input (Sink and source input type)	84
	Input wiring example	88
6.6	Output Wiring	90
	Relay output	90
	Transistor output	93
	Output wiring example	96
6.7	Analog Wiring	99
6.8	Examples of Wiring for Various Uses	100
	Built-in positioning function	100
	Communication function	100
	High-speed counter	101
	Interruption	105
CHAPTER 7 OPERATION ADJUSTMENT		106
7.1	Preparation for Operation	106
	Preliminary inspection	106
	Procedure until operation	107
	Connection with a personal computer	108
7.2	Operation and Test	109
	Self-diagnostic function	109
	Monitoring and debugging	109
7.3	Running, Stopping, and Resetting	110
	Methods of running, stopping, and resetting	110
CHAPTER 8 MAINTENANCE AND INSPECTION		111
8.1	Daily Inspection	111
8.2	Periodic Inspection	111
8.3	Battery	112
	Part names	112
	Specifications	112
	Battery attachment	112
	Battery replacement	114
	Special relay for low battery voltage	115
CHAPTER 9 TROUBLESHOOTING		116
9.1	Troubleshooting Procedure	116
9.2	Checking with LEDs	116
	Checking the PWR LED	116
	Checking the BAT LED	116
	Checking the ERR LED	117
	Checking the P.RUN LED	117
9.3	Error Status and Operations on Occurrence of an Error	117

9.4	Backing Up the Data	118
9.5	Canceling Errors	119
9.6	Troubleshooting for Each Symptom	119
	I/O operation (CPU module, I/O module)	119
	PLC write, PLC read	120
	Boot operation	120
APPENDIX		121
Appendix 1 How to Check the Date of Manufacture		121
Appendix 2 Standards		122
	Certification of UL, cUL standards	122
	Compliance with EC directive (CE Marking)	122
	Requirement for compliance with EMC directive	122
	Requirement for compliance with LVD directive	123
	Caution for compliance with EC Directive	123
Appendix 3 I/O Module		124
	Product configuration	124
	Product list	124
	Specifications	125
	External dimensions and component names	130
	Terminal layout	132
Appendix 4 SD Memory Card		133
	Part names	133
	Specifications	133
	Insertion and removal of the SD memory card	134
Appendix 5 Precautions for Battery Transportation		135
	Control-subject product	135
	Precautions for transportation	135
Appendix 6 Handling of Batteries and Devices with Built-in Batteries in EU Member States		136
	Disposal precautions	136
	Exportation precautions	136
INDEX		137
REVISIONS		138
WARRANTY		139
TRADEMARKS		140

RELEVANT MANUALS

User's manuals for the applicable modules

Manual name <manual number>	Description
FX5U Series Hardware Manual <JY997D53401>	Describes the details of input/output specifications, wiring and installation of the FX5U series CPU module from MELSEC iQ-F FX5U Series User's Manual [Hardware].
MELSEC iQ-F FX5 Series User's Manual [Startup] <JY997D58201>	Performance specifications, procedures before operation, and troubleshooting of the CPU module.
MELSEC iQ-F FX5U Series User's Manual [Hardware] <JY997D55301> (This manual)	Describes the details of hardware of the FX5U series CPU module, including input/output specifications, wiring, installation, and maintenance.
MELSEC iQ-F FX5 Series User's Manual [Application] <JY997D55401>	Describes basic knowledge required for program design, functions of the CPU module, devices/labels, and parameters.
MELSEC iQ-F FX5 Series Programming Manual [Program Design] <JY997D55701>	Describes specifications of ladders, ST, and other programs and labels.
MELSEC iQ-F FX5 Series Programming Manual [Instructions, Standard Functions/Function Blocks] <JY997D55801>	Describes specifications of instructions and functions that can be used in programs.
MELSEC iQ-F FX5 Series User's Manual [Serial Communication] <JY997D55901>	Describes inverter communication and non-protocol communication.
MELSEC iQ-F FX5 Series User's Manual [MODBUS Communication] <JY997D56101>	Describes MODBUS serial communication.
MELSEC iQ-F FX5 Series User's Manual [Ethernet Communication] <JY997D56201>	Describes the functions of the built-in Ethernet port communication function.
MELSEC iQ-F FX5 Series User's Manual [SLMP] <JY997D56001>	Explains methods for the device that is communicating with the CPU module by SLMP to read and write the data of the CPU module.
MELSEC iQ-F FX5 Series User's Manual [Positioning Control] <JY997D56301>	Describes the built-in positioning function.
GX Works3 Operating Manual <SH-081215ENG>	System configuration, parameter settings, and online operations of GX Works3.

TERMS

Unless otherwise specified, this manual uses the following terms.

- indicates a variable part to collectively call multiple models or versions.

(Example) FX5U-32MR/ES, FX5U-32MT/ES ⇔ FX5U-32M□/ES

- For details on the FX3 series devices that can be connected with the FX5U series, refer to  Page 33 PRODUCT LIST.

Terms	Description
■Series name	
FX5 series	Abbreviation of FX5 series PLCs
FX3 series	Generic term for FX3S, FX3G, FX3GC, FX3U, and FX3UC series PLCs
■Devices	
CPU module	Generic term for FX5U-32MR/ES, FX5U-32MT/ES, FX5U-32MT/ESS, FX5U-64MR/ES, FX5U-64MT/ES, FX5U-64MT/ESS, FX5U-80MR/ES, FX5U-80MT/ES, and FX5U-80MT/ESS
Extension module	Generic term for FX5 series extension modules and FX3 series extension modules
• FX5 series extension module	Generic term for I/O modules, extension power supply modules, and FX5 series intelligent function modules
• FX3 series extension module	Generic term for FX3 series extension power supply modules and special extension blocks
I/O module	Generic term for input modules, output modules, and powered input/output modules
• Input module	Generic term for FX5-8EX/ES and FX5-16EX/ES
• Output module	Generic term for FX5-8EYR/ES, FX5-8EYT/ES, FX5-8EYT/ESS, FX5-16EYR/ES, FX5-16EYT/ES, and FX5-16EYT/ESS
• Powered input/output module	Generic term for FX5-32ER/ES, FX5-32ET/ES, and FX5-32ET/ESS
Extension power supply module	Generic term for FX5-1PSU-5V and FX3U-1PSU-5V
Intelligent module	The abbreviation for intelligent function modules
Intelligent function module	Generic term for FX5 series intelligent function modules and FX3 series intelligent function modules
• FX5 series intelligent function module	Generic term for FX5 series intelligent function modules
• FX3 series intelligent function module	Generic term for FX3 series special extension blocks

Terms	Description
Simple motion module	Different name for FX5-40SSC-S
Expansion board	Generic term for board for FX5 series
• Communication board	Generic term for FX5-232-BD, FX5-485-BD, and FX5-422-BD-GOT
Expansion adapter	Generic term for adapter for FX5 series
• Communication adapter	Generic term for FX5-232ADP and FX5-485ADP
Bus conversion module	Different name for FX5-CNV-BUS
Battery	Different name for FX3U-32BL
SD memory card	Generic term for L1MEM-2GBSD and L1MEM-4GBSD SD memory cards. Abbreviation of Secure Digital Memory Card. Device that stores data using flash memory.
Peripheral device	Generic term for engineering tools and GOTs
GOT	Generic term for Mitsubishi Graphic Operation Terminal GOT1000 and GOT2000 series
■Software packages	
Engineering tool	Different name for GX Works3
GX Works3	The product name for the software package for the MELSEC programmable controllers
■Manuals	
User's manual	Generic term for separate manuals
User's manual [Startup]	Abbreviation of MELSEC iQ-F FX5 Series User's Manual [Startup]
User's manual [Hardware]	Abbreviation of MELSEC iQ-F FX5U Series User's Manual [Hardware]
User's manual [Application]	Abbreviation of MELSEC iQ-F FX5 Series User's Manual [Application]
Programming manual	Generic term for MELSEC iQ-F FX5 Series Programming Manual [Program design] and MELSEC iQ-F FX5 Series Programming Manual [Instructions, Standard Functions/Function Blocks]
Programming manual [Program Design]	Abbreviation of FX5 Series Programming Manual [Program Design]
Programming manual [Instructions, Standard Functions/Function Blocks]	Abbreviation of FX5 Series Programming Manual [Instructions, Standard Functions/Function Blocks]
Communication manual	Generic term for MELSEC iQ-F FX5 Series User's Manual [Serial Communication], MELSEC iQ-F FX5 Series User's Manual [MODBUS Communication], MELSEC iQ-F FX5 Series User's Manual [Ethernet Communication], and MELSEC iQ-F FX5 Series User's Manual [SLMP]
• Serial communication manual	Abbreviation of MELSEC iQ-F FX5 Series User's Manual [Serial Communication]
• MODBUS communication manual	Abbreviation of MELSEC iQ-F FX5 Series User's Manual [MODBUS Communication]
• Ethernet communication manual	Abbreviation of MELSEC iQ-F FX5 Series User's Manual [Ethernet Communication]
• SLMP manual	Abbreviation of MELSEC iQ-F FX5 Series User's Manual [SLMP]
Positioning manual	Abbreviation of MELSEC iQ-F FX5 Series User's Manual [Positioning Control]

1 OUTLINE

1.1 Part Names

Front panel

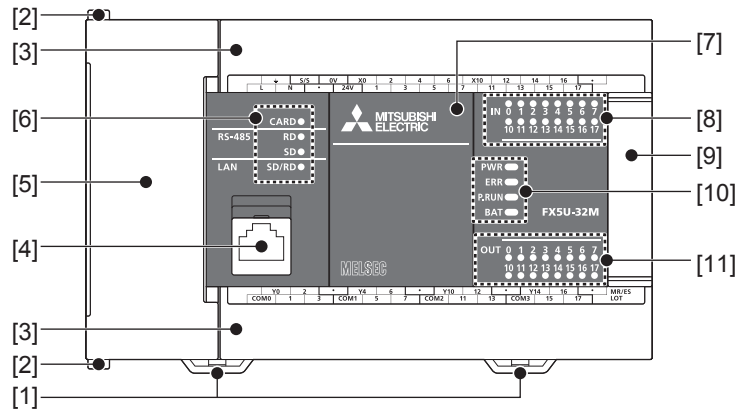

No.	Name	Description
[1]	DIN rail mounting hooks	Hook for mounting the CPU module on a DIN rail of DIN46277 (35 mm (1.38") wide).
[2]	Expansion adapter connecting hooks	When connecting an expansion adapter, secure it with these hooks.
[3]	Terminal block cover	Cover for protecting the terminal block. The cover can be opened for wiring. Keep the covers closed while equipment is running (power is on).
[4]	Built-in Ethernet communication connector	Connector for connection with Ethernet-compatible devices. (with cover) For details, refer to MELSEC iQ-F FX5 Series User's Manual [Ethernet Communication].
[5]	Top cover	Cover for protecting the SD memory card slot, the RUN/STOP/RESET switch, and others. The built-in RS-485 communication terminal block, built-in analog I/O terminal block, RUN/STOP/RESET switch, SD memory card slot, and others are located under this cover.
[6]	CARD LED	Indicates whether an SD memory card can be used or not. Lit: Can be used or cannot be removed. Flashing: In preparation Off: Not inserted or can be removed.
	RD LED	Lit when the CPU module is receiving data through built-in RS-485 communication.
	SD LED	Lit when the CPU module is sending data through built-in RS-485 communication.
	SD/RD LED	Lit when the CPU module is sending or receiving data through built-in Ethernet communication.
[7]	Expansion board connector cover	Cover for protecting expansion board connectors, battery, or others. Connect the battery under this cover.
[8]	Input display LED	Lit when input is on.
[9]	Extension connector cover	Cover for protecting the extension connector. Connect the extension cable of an extension module to the extension connector under the cover.
[10]	PWR LED	Indicates whether the CPU module is powered or not. Lit: Powered Off: Not powered or hardware error (☞ Page 116 Checking with LEDs)
	ERR LED	Indicates the error status of the CPU module. (☞ Page 116 Checking with LEDs) Lit: Error or hardware error Flashing: Error, hardware error, or resetting Off: Operating normally
	P.RUN LED	Indicates the program running status. Lit: Operating normally Flashing: Paused Off: Stopped or stop error
	BAT LED	Indicates the battery status. Flashing: Battery error Off: Operating normally (☞ Page 116 Checking with LEDs)
[11]	Output display LED	Lit when output is on.

With cover open

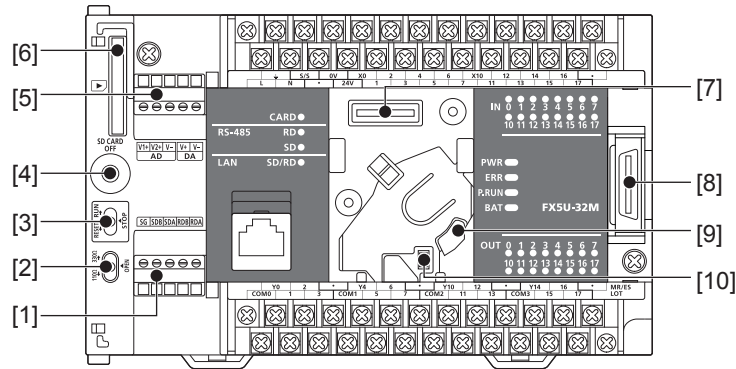

No.	Name	Description
[1]	Built-in RS-485 communication terminal block	Terminal block for connection with RS-485-compatible devices
[2]	RS-485 terminal resistor selector switch	Switch for switching terminal resistance for built-in RS-485 communication.
[3]	RUN/STOP/RESET switch	Switch for operating the CPU module. (☞ Page 110 Methods of running, stopping, and resetting) RUN: Runs the program STOP: Stops the program RESET: Resets the CPU module (hold the switch on the RESET side for approximately 1 second.)
[4]	SD memory card disable switch	Switch for disabling access to the SD memory card when the card is to be removed.
[5]	Built-in analog I/O terminal block	Terminal block for using the built-in analog function.
[6]	SD memory card slot	Slot for inserting an SD memory card.
[7]	Expansion board connector	Connector for connecting an expansion board.
[8]	Extension connector	Connector for connecting the extension cable of an extension module.
[9]	Battery holder	Holder for storing an optional battery.
[10]	Battery connector	Connector for connecting an optional battery.

Point

Use a tool such as a screwdriver to operate RS-485 terminal resistor selector switch. Make sure that the edge of the tool does not damage the switch or the case.

When the terminal block covers are open

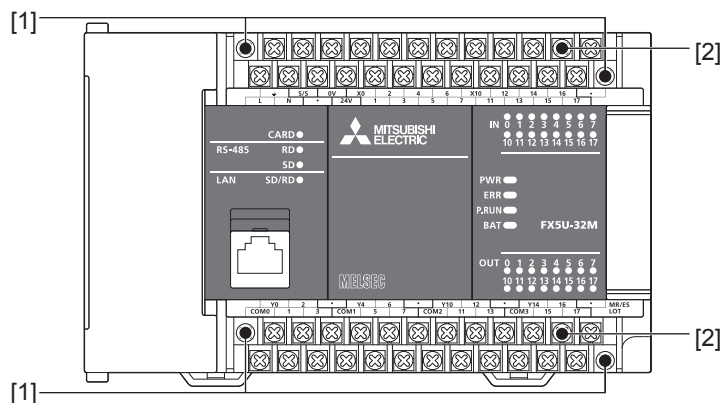

No.	Name	Description
[1]	Terminal block mounting screws	Gradually loosen the left and right screws (alternately), and remove the top of the terminal blocks.
[2]	Terminal	Terminals for power, input, and output. For details on the terminal layout, refer to ☞ Page 30 Terminal Layout

Side

Left side/right side

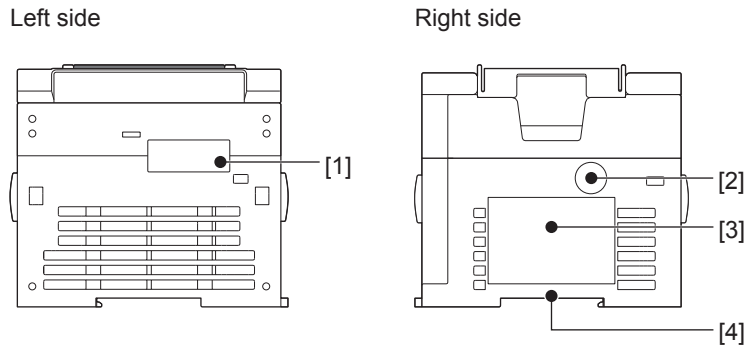

No.	Name	Description
[1]	Expansion adapter connector cover	Cover for protecting the expansion adapter connector. Connect the expansion adapter to the expansion adapter connector under the cover.
[2]	Genuine product certification label	Genuine product certification label to prevent counterfeiting
[3]	Nameplate	The product model name, Manufacturer's serial number, power supply specifications, and MAC address are shown.
[4]	DIN rail mounting groove	The module can be installed on DIN46277 rail (35 mm (1.38") wide).

Point

Products that do not have the genuine product certification label or nameplate are not covered by the warranty.

Top side/bottom side

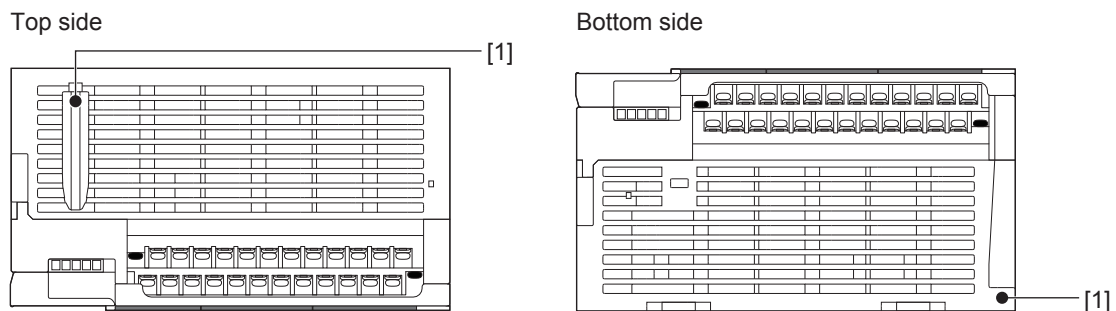

No.	Name	Description
[1]	CPU module fixing screw hole	Screw holes for fixing the CPU module to the panel. (In the case of FX5U-64M□/80M□, there are four screw holes.)

2 SPECIFICATIONS

The CPU module specifications are explained below.

2.1 Generic Specifications

Item	Specifications				
Operating ambient temperature* ¹	0 to 55°C (32 to 131 °F)* ²				
Storage ambient temperature	-25 to 75°C (-13 to 167 °F)				
Operating ambient humidity	5 to 95%RH, non-condensation				
Storage ambient humidity	5 to 95%RH, non-condensation				
Vibration resistance* ^{3,4}	—	Frequency	Acceleration	Half amplitude	Sweep count 10 times each in X, Y, Z directions (80 min in each direction)
	Installed on DIN rail	5 to 8.4 Hz	—	1.75 mm	
		8.4 to 150 Hz	4.9 m/s ²	—	
	Direct installing	5 to 8.4 Hz	—	3.5 mm	
8.4 to 150 Hz		9.8 m/s ²	—		
Shock resistance* ³	147 m/s ² , Action time: 11 ms, 3 times by half-sine pulse in each direction X, Y, and Z				
Noise durability	By noise simulator at noise voltage of 1000 Vp-p, noise width of 1 μs and period of 30 to 100 Hz				
Grounding	Class D grounding (grounding resistance: 100 Ω or less) <Common grounding with a heavy electrical system is not allowed.>* ⁵				
Working atmosphere	Free from corrosive or flammable gas and excessive conductive dust				
Operating altitude* ⁶	0 to 2000 m				
Installation location	Inside a control panel				
Overvoltage category* ⁷	II or less				
Pollution degree* ⁸	2 or less				
Equipment class	Class 2				

*1 The simultaneous ON ratio of available PLC inputs or outputs changes with respect to the ambient temperature, refer to  Page 24 Input/Output Derating Curve.

*2 For details on Intelligent function modules, refer to  manuals of each product.

*3 The criterion is shown in IEC61131-2.

*4 When the system has equipment which specification values are lower than above mentioned vibration resistance specification values, the vibration resistance specification of the whole system is corresponding to the lower specification.

*5 For grounding, refer to  Page 79

*6 The PLC cannot be used at a pressure higher than the atmospheric pressure to avoid damage.

*7 This indicates the section of the power supply to which the equipment is assumed to be connected between the public electrical power distribution network and the machinery within premises. Category II applies to equipment for which electrical power is supplied from fixed facilities. The surge voltage withstand level for up to the rated voltage of 300 V is 2500 V.

*8 This index indicates the degree to which conductive material is generated in the environment in which the equipment is used. Pollution level 2 is when only non-conductive pollution occurs. Temporary conductivity caused by condensation must be expected occasionally.

Dielectric withstand voltage test and insulation resistance test

Perform dielectric withstand voltage test and insulation resistance test at the following voltages between each terminal and the CPU module ground terminal.

■ CPU module, I/O module

Between terminals	Dielectric withstand voltage	Insulation resistance	Remarks
Between power supply terminal (AC power supply) and ground terminal	1.5 kV AC for one minute	10 MΩ or higher by 500 V DC insulation resistance tester	—
Between 24 V DC service power supply connected to input terminal (24 V DC) and ground terminal	500 V AC for one minute		—
Between output terminal (relay) and ground terminal	1.5 kV AC for one minute		—
Between output terminal (transistor) and ground terminal	500 V AC for one minute		—

■Expansion board, expansion adapter

Between terminals	Dielectric withstand voltage	Insulation resistance	Remarks
Between terminal of expansion board and ground terminal	Not allowed	Not allowed	Since the expansion board and CPU module are not insulated, it is not allowed to perform the dielectric withstand voltage test and insulation resistance test between them.
Between terminal of expansion adapter and ground terminal	500 V AC for one minute	10 MΩ or higher by 500 V DC insulation resistance tester	—

■Intelligent function module

For information concerning dielectric withstand voltage and insulation resistance of intelligent function modules, refer to  manuals of each intelligent function module.

2.2 Power Supply Specifications

The CPU module power supply specifications are explained below.

For the consumption current of extension modules, refer to  Page 33 PRODUCT LIST or manuals of each extension module.

AC power supply

Item	Specifications	
Rated voltage	100 to 240 V AC	
Allowable supply voltage range	85 to 264 V AC	
Frequency rating	50/60 Hz	
Allowable instantaneous power failure time	Operation can be continued upon occurrence of instantaneous power failure for 10 ms or less.	
Power fuse	FX5U-32M□	250 V, 3.15 A Time-lag fuse
	FX5U-64M□, FX5U-80M□	250 V, 5 A Time-lag fuse
Rush current	FX5U-32M□	25 A max. 5 ms or less/100 V AC 50 A max. 5 ms or less/200 V AC
	FX5U-64M□, FX5U-80M□	30 A max. 5 ms or less/100 V AC 60 A max. 5 ms or less/200 V AC
Power consumption*1	FX5U-32M□	30 W
	FX5U-64M□	40 W
	FX5U-80M□	45 W
24 V DC service power supply capacity*2	FX5U-32M□	400 mA (Supply capacity when service power supply is used for input circuit of the CPU module)
		480 mA (Supply capacity when external power supply is used for input circuit of the CPU module)
	FX5U-64M□	600 mA (Supply capacity when service power supply is used for input circuit of the CPU module)
		740 mA (Supply capacity when external power supply is used for input circuit of the CPU module)
	FX5U-80M□	600 mA (Supply capacity when service power supply is used for input circuit of the CPU module)
		770 mA (Supply capacity when external power supply is used for input circuit of the CPU module)
5 V DC power supply capacity	FX5U-32M□	900 mA
	FX5U-64M□, FX5U-80M□	1100 mA

*1 This item shows value when all 24 V DC service power supplies are used in the maximum configuration connectable to the CPU module. (The current of the input circuit is included.)



*2 When I/O modules are connected, they consume current from the 24 V DC service power.
For details on the service power supply, refer to  Page 49 Limitation on Current Consumption.

2.3 Input Specifications

The CPU module input specifications are explained below.

24 V DC Input (sink/source)

The input points in the table below indicate the CPU module terminal points.

Item		Specifications		
No. of input points	FX5U-32M□	16 points		
	FX5U-64M□	32 points		
	FX5U-80M□	40 points		
Connection type		Removable terminal block (M3 screws)		
Input type		Sink/source		
Input signal voltage		24 V DC +20 %, -15%		
Input signal current	X000 to X017	5.3 mA/24 V DC		
	X020 and subsequent	4.0 mA/24 V DC		
Input impedance	X000 to X017	4.3 kΩ		
	X020 and subsequent	5.6 kΩ		
ON input sensitivity current	X000 to X017	3.5 mA or more		
	X020 and subsequent	3.0 mA or more		
OFF input sensitivity current		1.5 mA or less		
Input response frequency	FX5U-32M□	X000 to X005	200 kHz When capturing pulses of a response frequency of 50 to 200 kHz, refer to  Page 87 In the case of capturing high-speed pulses.	
	FX5U-64M□, FX5U-80M□	X000 to X007		
	FX5U-32M□	X006 to X017		
	FX5U-64M□, FX5U-80M□	X010 to X017		
Pulse waveform	Waveform			
			T1 (pulse width)	
			T2 (rise/fall time)	
	FX5U-32M□	X000 to X005	2.5 μs or more	1.25 μs or less
	FX5U-64M□, FX5U-80M□	X000 to X007		
	FX5U-32M□	X006 to X017	50 μs or more	25 μs or less
Input response time (H/W filter delay)	FX5U-32M□	X000 to X005	ON: 2.5 μs or less	
	FX5U-64M□, FX5U-80M□	X000 to X007	OFF: 2.5 μs or less	
	FX5U-32M□	X006 to X017	ON: 30 μs or less	
	FX5U-64M□, FX5U-80M□	X010 to X017	OFF: 50 μs or less	
	FX5U-64M□, FX5U-80M□	X020 and subsequent	ON: 50 μs or less OFF: 150 μs or less	
Input response time (Digital filter setting value)		None, 10 μs, 50 μs, 0.1 ms, 0.2 ms, 0.4 ms, 0.6 ms, 1 ms, 5 ms, 10 ms (initial values), 20 ms, 70 ms When using this product in an environment with much noise, set the digital filter.		
Input signal format		No-voltage contact input Sink: NPN open collector transistor Source: PNP open collector transistor		
Input circuit insulation		Photo-coupler insulation		
Indication of input operation		LED is lit when input is on		

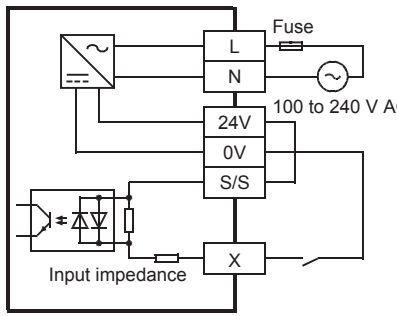
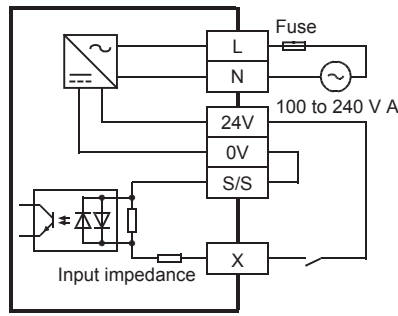
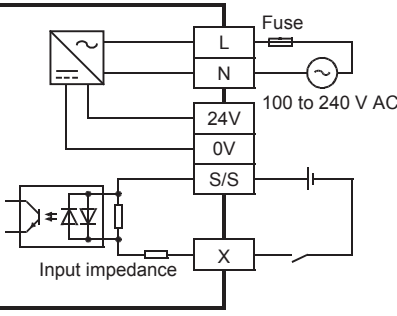
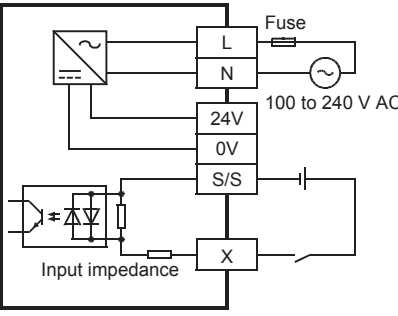
Item	Specifications
Input circuit configuration	<ul style="list-style-type: none"> When using service power supply <div style="display: flex; justify-content: space-around;"> <div style="text-align: center;"> <p>Sink input wiring</p>  </div> <div style="text-align: center;"> <p>Source input wiring</p>  </div> </div> When using external power supply <div style="display: flex; justify-content: space-around;"> <div style="text-align: center;"> <p>Sink input wiring</p>  </div> <div style="text-align: center;"> <p>Source input wiring</p>  </div> </div>

2.4 Output Specifications

The CPU module output specifications are explained below.

Relay output

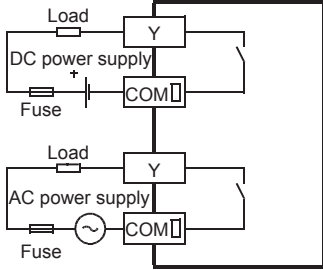
Item		Output Specifications
No. of output points	FX5U-32MR/□	16 points
	FX5U-64MR/□	32 points
	FX5U-80MR/□	40 points
Connection type		Removable terminal block (M3 screws)
Output type		Relay
External power supply		30 V DC or less 240 V AC or less ("250 V AC or less" if not a CE, UL, cUL compliant item)
Max. load		2 A/point The total load current per common terminal should be the following value. <ul style="list-style-type: none"> • 4 output points/common terminal: 8 A or less • 8 output points/common terminal: 8 A or less For details on the common, refer to  Page 31 Terminal Layout
Min. load		5 V DC, 2 mA (reference values)
Open circuit leakage current		—
Response time	OFF→ON	Approx. 10 ms
	ON→OFF	Approx. 10 ms
Insulation of circuit		Mechanical insulation
Indication of output operation		LED is lit when output is on
Output circuit configuration		 <p>A number is entered in the □ of [COM □].</p>

Transistor output

Item		Output specifications
No. of output points	FX5U-32MT/□	16 points
	FX5U-64MT/□	32 points
	FX5U-80MT/□	40 points
Connection type		Removable terminal block (M3 screws)
Output type	FX5U-□MT/ES	Transistor/sink output
	FX5U-□MT/ESS	Transistor/source output
External power supply		5 to 30 V DC
Max. load		0.5 A/point The total load current per common terminal should be the following value. <ul style="list-style-type: none"> • 4 output points/common terminal: 0.8 A or less • 8 output points/common terminal: 0.8 A or less For details on the common, refer to Page 31 Terminal Layout
Open circuit leakage current		0.1 mA or less/30 V DC
Voltage drop when ON	Y000 to Y003	1.0 V or less
	Y004 and subsequent	1.5 V or less
Response time	Y000 to Y003	2.5 μs or less/10 mA or more (5 to 24 V DC)
	Y004 and subsequent	0.2 ms or less/200 mA or more (24 V DC)
Insulation of circuit		Photo-coupler insulation
Indication of output operation		LED is lit when output is on
Output circuit configuration		<div style="display: flex; justify-content: space-around;"> <div style="text-align: center;"> <p>Sink output wiring</p> <p>A number is entered in the □ of [COM].</p> </div> <div style="text-align: center;"> <p>Source output wiring</p> <p>A number is entered in the □ of [+V].</p> </div> </div>

2.5 Input/Output Derating Curve

The derating curve below shows the simultaneous ON ratio of available PLC inputs or outputs with respect to the ambient temperature. Use the PLC within the simultaneous input or output ON ratio range shown in the figure.

Derating curve

When service power supply or external power supply (24 V DC) is used for input circuits

Simultaneous ON ratio

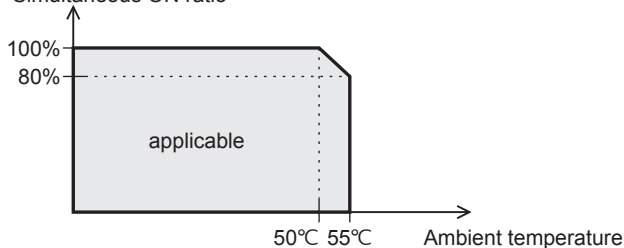

2.6 Performance Specifications

Item		Specification
Control system		Stored-program repetitive operation
Input/output control system		Refresh system (Direct access input/output allowed by specification of direct access input/output [DX, DY])
Programming specifications	Programming language	Ladder diagram (LD), structured text (ST)
	Programming extension function	Function block (FB), structured ladder, label programming (local/global)
	Constant scan	0.2 to 2000 ms (can be set in 0.1 ms increments)
	Fixed cycle interrupt	1 to 60000 ms (can be set in 1 ms increments)
	Timer performance specifications	100 ms, 10 ms, 1 ms
	No. of program executions	32
	No. of FB files	16
Operation specifications	Execution type	Standby type, initial execution type, scan execution type, event execution type
	Interrupt type	Internal timer interrupt, input interruption, high-speed comparison match interrupt
Command processing time	LD X0	34 ns
	MOV D0 D1	34 ns
Memory capacity	Program capacity	64 k steps (128 kbytes, flash memory)
	SD memory card	Memory card capacity (SD/SDHC memory card: Max. 4 Gbytes)
	Device/label memory	120 kbytes
	Data memory/standard ROM	5 Mbytes
Flash memory (Flash ROM) write count		Maximum 20000 times
File storage capacity	Device/label memory	1
	Data memory	P: 32, FB: 16
	P: No. of program files FB: No. of FB files	
Clock function	Display data	Year, month, day, hour, minute, second, day of week (leap year automatic detection)
	Precision	-2.96 to +3.74 (TYP.+1.42) s/d (Ambient temperature: 0°C (32°F)) -3.18 to +3.74 (TYP.+1.50) s/d (Ambient temperature: 25°C (77°F)) -13.20 to +2.12 (TYP.-3.54) s/d (Ambient temperature: 55°C (131°F))
No. of input/output points	(1) No. of input/output points	256 points or less
	(2) No. of remote I/O points	384 points or less
	Total No. of points of (1) and (2)	512 points or less
Power failure retention*1	Retention method	Large-capacity capacitor
	Retention time	10 days (Ambient temperature: 25°C (77°F))
	Data retained	Clock data

*1 Clock data is retained using the power accumulated in a large-capacity capacitor incorporated into the PLC. When voltage of the large-capacity capacitor drops, clock data is no longer accurately retained. The retention period of a fully charged capacitor (electricity is conducted across the PLC for at least 30 minutes) is 10 days (ambient temperature: 25°C (77°F)). How long the capacitor can hold the data depends on the operating ambient temperature. When the operating ambient temperature is high, the holding period is short.

Number of device points

Item		Base	Max. number of points	
No. of user device points	Input relay (X)	8	1024 points	
	Output relay (Y)	8	1024 points	
	Internal relay (M)	10	32768 points (can be changed with parameter) ^{*1}	
	Latch relay (L)	10	32768 points (can be changed with parameter) ^{*1}	
	Link relay (B)	16	32768 points (can be changed with parameter) ^{*1}	
	Annunciator (F)	10	32768 points (can be changed with parameter) ^{*1}	
	Link special relay (SB)	16	32768 points (can be changed with parameter) ^{*1}	
	Step relay (S)	10	4096 points (fixed)	
	Timer system	Timer (T)	10	1024 points (can be changed with parameter) ^{*1}
	Accumulation timer system	Accumulation timer (ST)	10	1024 points (can be changed with parameter) ^{*1}
	Counter system	Counter (C)	10	1024 points (can be changed with parameter) ^{*1}
		Long counter (LC)	10	1024 points (can be changed with parameter) ^{*1}
	Data register (D)		10	8000 points (can be changed with parameter) ^{*1}
	Link register (W)		16	32768 points (can be changed with parameter) ^{*1}
	Link special register (SW)		16	32768 points (can be changed with parameter) ^{*1}
No. of system device points	Special relay (SM)	10	10000 points (fixed)	
	Special register (SD)	10	12000 points (fixed)	
Module access device	Intelligent function module device	10	65536 points (designated by U□\G□)	
No. of index register points	Index register (Z) ^{*2}	10	24 points	
	Long index register (LZ) ^{*2}	10	12 points	
No. of file register points	File register (R)	10	32768 points (can be changed with parameter) ^{*1}	
No. of nesting points	Nesting (N)	10	15 points (fixed)	
No. of pointer points	Pointer (P)	10	4096 points	
	Interrupt pointer (I)	10	178 points (fixed)	
Others	Decimal constant (K)	Signed	—	16 bits: -32768 to +32767, 32 bits: -2147483648 to +2147483647
		Unsigned	—	16 bits: 0 to 65535, 32 bits: 0 to 4294967295
	Hexadecimal constant (H)	—	16 bits: 0 to FFFF, 32 bits: 0 to FFFFFFFF	
	Real constant (E)	Single precision	—	E-3.40282347+38 to E-1.17549435-38, 0, E1.17549435-38 to E3.40282347+38
	Character string		—	Shift-JIS code max. 255 single-byte characters (256 including NULL)

*1 Can be changed with parameters within the capacity range of the CPU built-in memory.

*2 Total of the index register (Z) and long index register (LZ) is maximum 24 words.

2.7 Built-in Analog Specifications

The analog input/output specifications of the built-in analog function are explained below.

For details on the analog built-in function, refer to [MELSEC iQ-F FX5 Series User's Manual \[Application\]](#).

Analog input

Item		Specifications
Analog input points		2 points (2 channels)
Analog input	Voltage	0 to 10 V DC (input resistance 115.7 kΩ)
Digital output		Unsigned 12-bit binary
I/O characteristics, Maximum resolution	Digital output value	0 to 4000
	Maximum resolution	2.5 mV
Accuracy (Accuracy in respect to maximum digital output value)	Ambient temperature 25 ±5°C (77 ±41°F)	Within ±0.5% (±20 digit ^{*1})
	Ambient temperature 0 to 55°C (32 to 131°F)	Within ±1.0% (±40 digit ^{*1})
Conversion speed		30 μs /channels (data refreshed every operation cycle)
Absolute maximum input		-0.5 V, +15 V
Insulation method	Between input terminal and PLC	Not insulated
	Between input terminals	Not insulated
Occupied points		0 points (does not pertain to the max. No. of input/output points of the PLC.)
Terminal block used		European-type terminal block

*1 "Digit" refers to digital values.

Analog output

Item		Specifications
Analog output points		1 points (1 channels)
Digital input		Unsigned 12-bit binary
Analog output	Voltage	0 to 10 V DC (external load resistance 2 k to 1 MΩ)
I/O characteristics, Maximum resolution ^{*1}	Digital input value	0 to 4000
	Maximum resolution	2.5 mV
Accuracy ^{*2} (Accuracy in respect to maximum analog output value)	Ambient temperature 25 ±5°C (77 ±41°F)	Within ±0.5% (±20 digit ^{*3})
	Ambient temperature 0 to 55°C (32 to 131°F)	Within ±1.0% (±40 digit ^{*3})
Conversion speed		30 μs (data refreshed every operation cycle)
Insulation method	Between output terminal and PLC	Not insulated
Occupied points		0 points (does not pertain to the max. No. of input/output points of the PLC.)
Terminal block used		European-type terminal block

*1 There is a dead band near 0 V output, which is an area where some analog output values do not reflect digital input values.

*2 External load resistance is set to 2 kΩ when shipped from the factory. Thus, output voltage will increase somewhat if the resistance is set higher than 2 kΩ. When the resistance is 1 MΩ, output voltage increases maximum 2%.

*3 "Digit" refers to digital values.

2.8 Communication Specifications

The built-in Ethernet and built-in RS-485 communication specifications are as explained below.

Built-in Ethernet communication

For details on built-in Ethernet communication, refer to [MELSEC iQ-F FX5 Series User's Manual \[Ethernet Communication\]](#).

Item	Specifications	
Data transmission speed	100/10 Mbps	
Communication mode	Full duplex (FDX) / half duplex (HDX)	
Interface	RJ45 connector	
Transmission method	Base band	
Maximum segment length (The distance between hub and node)	100 m (328'1")	
Cascade connection	100BASE-TX	Cascade connection max. 2 stages*1
	10BASE-T	Cascade connection max. 4 stages*1
Protocol type	MELSOFT connection	
	SLMP (3E frame)	
	Socket communication	
Number of simultaneously open connections allowed	Total of 8 for socket communication, MELSOFT connection, and SLMP (Up to 8 external devices can access one CPU module at the same time.)	
Insulation method	Pulse transformer insulation	
Cable used*2	For 100BASE-TX connection	Ethernet standard-compatible cable, category 5 or higher (STP cable)
	For 10BASE-T connection	Ethernet standard-compatible cable, category 3 or higher (STP cable)

*1 Number of stages that can be connected when a repeater hub is used. When a switching hub is used, check the specifications of the switching hub used.

*2 A straight cable can be used. If a personal computer or GOT and CPU module are directly connected a cross cable can be used.

Built-in RS-485 communication

For details on built-in RS-485 communication, refer to the following.

[MELSEC iQ-F FX5 Series User's Manual \[Serial Communication\]](#)

[MELSEC iQ-F FX5 Series User's Manual \[MODBUS Communication\]](#)

Item	Specifications
Transmission standards	Conforms to RS-485/RS-422 specifications
Data transmission speed	Max. 115.2 kbps
Communication method	Full duplex (FDX) / half duplex (HDX)
Maximum total extension distance	50 m (164'0")
Protocol type	MELSOFT connection
	Non-protocol communication
	MODBUS RTU
	Inverter communication
Insulation method	Not insulated
Terminal resistors	Built-in (OPEN/110 Ω/330 Ω)
Terminal block used	European-type terminal block

2.9 External Dimensions

FX5U-32M□

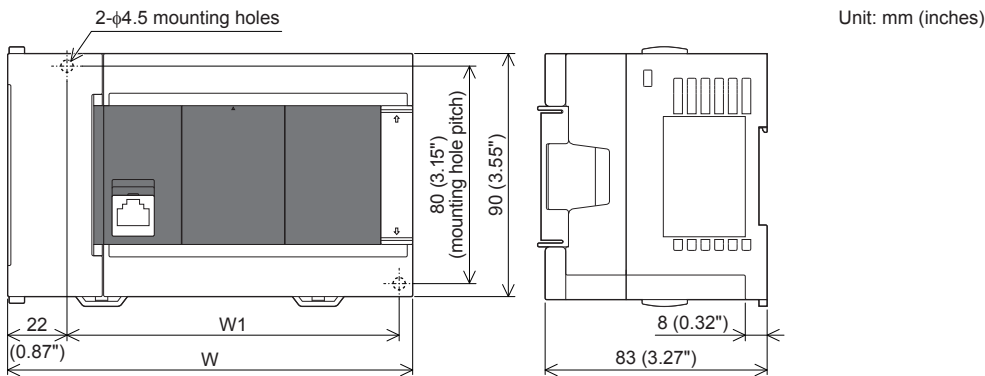

Model	W	W1 (mounting hole pitch)	Mass (weight)
FX5U-32M□	150 mm (5.91")	123 mm (4.85")	Approx. 0.65 kg (1.43 lbs)

- Exterior color

Main body: Munsell 0.6B7.6/0.2

- Accessories

Dust proof protection sheet
Manual supplied with product

FX5U-64M□, FX5U-80M□

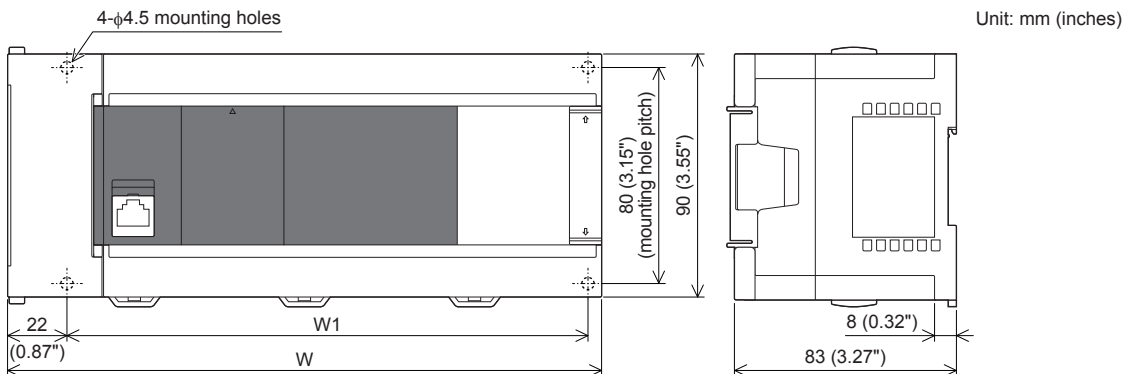

Model	W	W1 (mounting hole pitch)	Mass (weight)
FX5U-64M□	220 mm (8.67")	193 mm (7.6")	Approx. 1.0 kg (2.2 lbs)
FX5U-80M□	285 mm (11.23")	258 mm (10.16")	Approx. 1.2 kg (2.64 lbs)

- Exterior color

Main body: Munsell 0.6B7.6/0.2

- Accessories

Dust proof protection sheet
Manual supplied with product

2.10 Terminal Layout

Built-in RS-485 terminal

European type terminal block

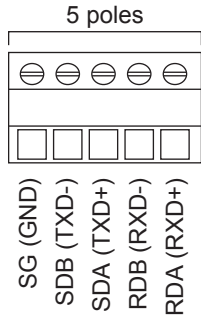

Built-in analog terminal

European type terminal block

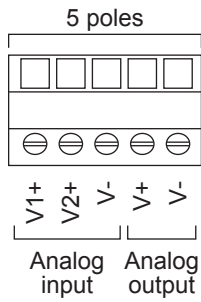

Built-in Ethernet connector

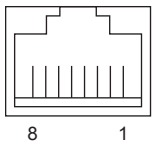

Pin	Signal name
1	TD+
2	TD-
3	RD+
4	Not used
5	Not used
6	RD-
7	Not used
8	Not used

Power, input/output terminal block

■ Interpretation of terminal block layout

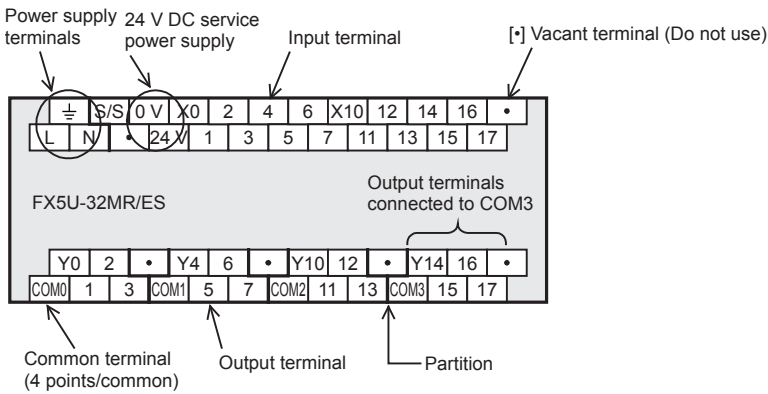

- Indication of power supply terminals
[L] and [N] terminals.
For external wiring, refer to Page 80 Power Supply Wiring.
- Indication of 24 V DC service power supply
[0V] and [24V] terminals.
- Indication of input terminal
For external wiring, refer to Page 84 Input Wiring.
- Indication of output terminals connected to common (COM□)
One common terminal covers 4 or 8 output points.
The output number (Y) connected to common is the range inside the thick "separation line."
For transistor output (source) type, the "COM□" terminal is the "+V□" terminal.

■ FX5U-32M□

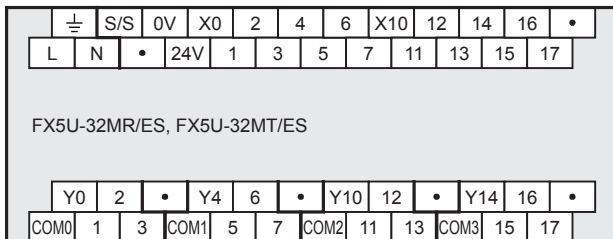

FX5U-32MT/ESS

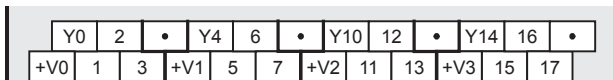

■ FX5U-64M□

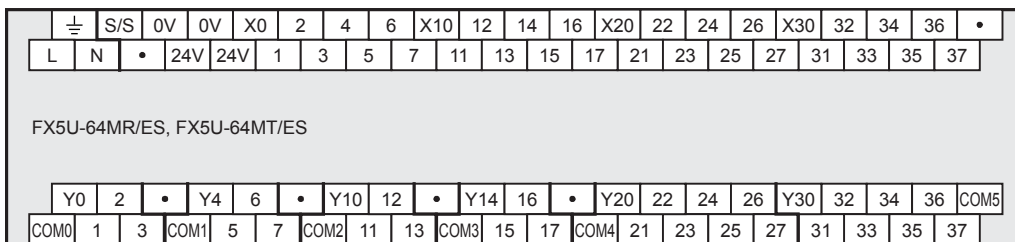

FX5U-64MT/ESS

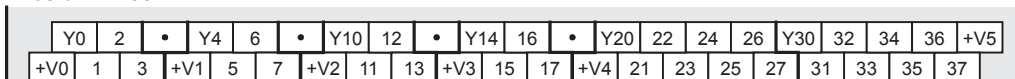

3 PRODUCT LIST

The following shows the system configuration equipment of the FX5U series.

3.1 Overall Configuration

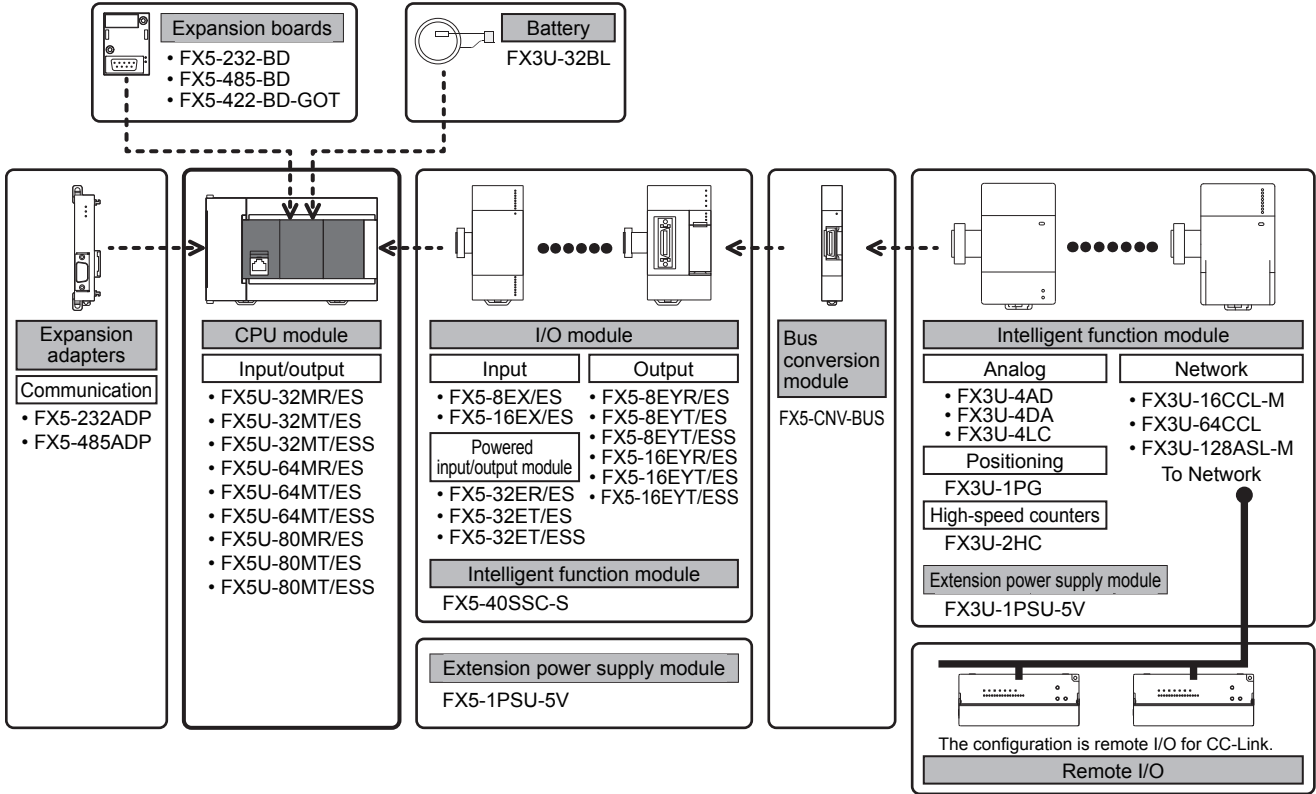

3.2 CPU Module

The CPU module incorporates a CPU, memory, input/output terminals, and power supply.

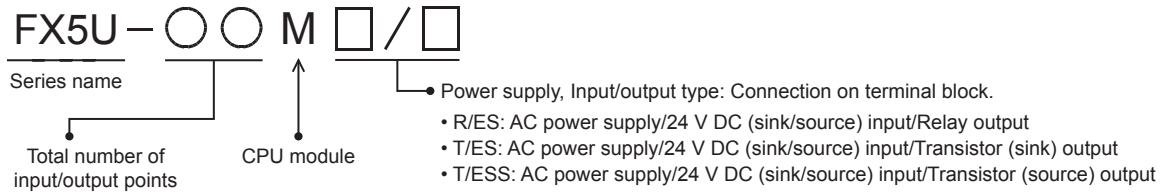

AC power supply common to 24 V DC sink and source input

Model	No. of input/output points			Input type	Output type	Connection type	Power supply capacity	
	Total No. of points	No. of input points	No. of output points				5 V DC power supply	24 V DC service power supply
FX5U-32MR/ES	32 points	16 points	16 points	24 V DC (Sink/source)	Relay	Terminal block	900 mA	400 mA (480 mA ^{*1})
FX5U-32MT/ES					Transistor (sink)			
FX5U-32MT/ESS					Transistor (source)			
FX5U-64MR/ES	64 points	32 points	32 points	24 V DC (Sink/source)	Relay	Terminal block	1100 mA	600 mA (740 mA ^{*1})
FX5U-64MT/ES					Transistor (sink)			
FX5U-64MT/ESS					Transistor (source)			
FX5U-80MR/ES	80 points	40 points	40 points	24 V DC (Sink/source)	Relay	Terminal block	1100 mA	600 mA (770 mA ^{*1})
FX5U-80MT/ES					Transistor (sink)			
FX5U-80MT/ESS					Transistor (source)			

*1 Power supply capacity when external power supply is used for input circuit

Point

The model name of the CPU module can be checked on the nameplate on the right side. However, when extension modules are connected, the nameplate cannot be seen. Check the model name in the following places.

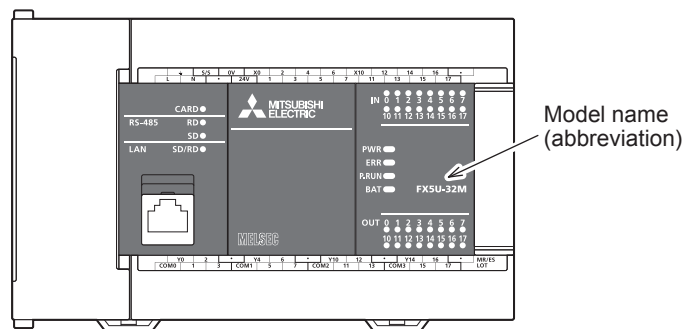

3.3 I/O Module

The I/O module is used to expand inputs/outputs.
 For details, refer to  Page 124 I/O Module.

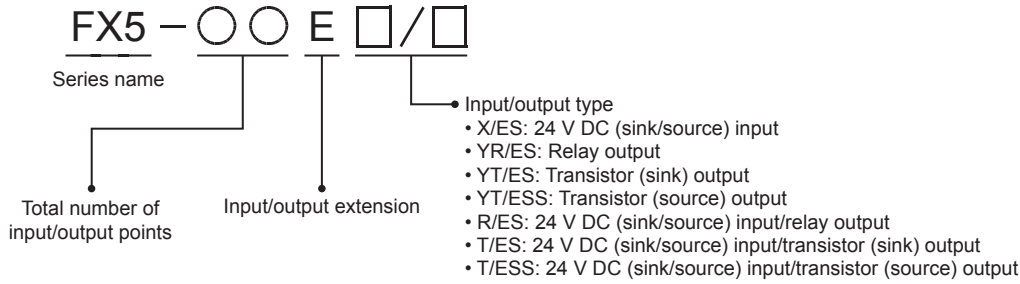

Input module

The input module is used to expand inputs.

Model	No. of input/output points			Input type	Output type	Connection type	Current consumption	
	Total No. of points	No. of input points	No. of output points				5 V DC power supply	24 V DC power supply
FX5-8EX/ES	8 points	8 points	—	24 V DC (Sink/source)	—	Terminal block	75 mA	50 mA
FX5-16EX/ES	16 points	16 points					100 mA	85 mA

Output module

The output module is used to expand outputs.

Model	No. of input/output points			Input type	Output type	Connection type	Current consumption	
	Total No. of points	No. of input points	No. of output points				5 V DC power supply	24 V DC power supply
FX5-8EYR/ES	8 points	—	8 points	—	Relay	Terminal block	75 mA	75 mA
FX5-8EYT/ES					Transistor (sink)			
FX5-8EYT/ESS					Transistor (source)			
FX5-16EYR/ES	16 points	—	16 points	—	Relay	Terminal block	100 mA	125 mA
FX5-16EYT/ES					Transistor (sink)			
FX5-16EYT/ESS					Transistor (source)			

Powered input/output module

The powered input/output module includes a power supply and is used to expand input/output.

Model	No. of input/output points			Input type	Output type	Connection type	Power supply capacity	
	Total No. of points	No. of input points	No. of output points				5 V DC power supply	24 V DC service power supply
FX5-32ER/ES	32 points	16 points	16 points	24 V DC (Sink/source)	Relay	Terminal block	965 mA	250 mA (310 mA*1)
FX5-32ET/ES					Transistor (sink)			
FX5-32ET/ESS					Transistor (source)			

*1 Power supply capacity when external power supply is used for input circuit

3.4 Intelligent Function Module

Intelligent function modules are modules that have functions other than input/output, such as simple motion modules. For details, refer to  manuals of each module.

FX5 series

Positioning					
Model	Function	No. of occupied input/output points	Current consumption		Power consumption
			5 V DC power supply	24 V DC power supply	External 24 V DC power supply
FX5-40SSC-S	4-axis control (compatible with SSCNET III/H)	8 points	—	—	6 W

FX3 series

With FX5U series systems, the following intelligent function modules of the FX3 series can be used.

However, a bus conversion module is required to use the intelligent function modules.

For details, refer to  Page 42 Bus conversion module.

Analog					
Model	Function	No. of occupied input/output points	Current consumption		
			5 V DC power supply	24 V DC power supply	External 24 V DC power supply
FX3U-4AD	4-ch voltage/current input	8 points	110 mA	—	90 mA
FX3U-4DA	4-ch voltage/current output		120 mA	—	160 mA
FX3U-4LC	4-loop temperature control (resistance thermometer/thermocouple/low voltage)		160 mA	—	50 mA

Positioning					
Model	Function	No. of occupied input/output points	Current consumption		
			5 V DC power supply	24 V DC power supply	External 24 V DC power supply
FX3U-1PG	Pulse output for independent 1-axis control	8 points	150 mA	—	40 mA

High-speed counter					
Model	Function	No. of occupied input/output points	Current consumption		
			5 V DC power supply	24 V DC power supply	External 24 V DC power supply
FX3U-2HC	2-ch high-speed counter	8 points	245 mA	—	—

Network

Model	Function	No. of occupied input/output points	Current consumption		
			5 V DC power supply	24 V DC power supply	External 24 V DC power supply
FX3U-16CCCL-M ^{*1}	Master for CC-Link (compatible with Ver. 2.00 and Ver. 1.10)	8 points ^{*2}	—	—	240 mA
FX3U-64CCCL ^{*1}	Intelligent device station for CC-Link	8 points	—	—	220 mA
FX3U-128ASL-M ^{*1}	Master for AnyWireASLINK	8 points ^{*3}	130 mA	—	100 mA ^{*4}

*1 GX Works3 does not support this module. When using this module, perform setting via buffer memory.

*2 Number of remote I/O points is added.

For details, refer to  Page 48 Calculation of number of remote I/O points.

*3 The number of input/output points set by the rotary switch is added. For details, refer to  the user's manuals of FX3U-128ASL-M.

*4 This value does not include supply current to slave modules. For details, refer to  manuals of each product.

3.5 Expansion Board

The expansion board is to expand functions and is connected to the front face of the CPU module.

For details on the specifications of the expansion board, refer to  Hardware manuals of each product.

Model	Function	No. of occupied input/output points	Current consumption		
			5 V DC power supply	24 V DC power supply	External 24 V DC power supply
FX5-232-BD	For RS-232C communication	—	20 mA	—	—
FX5-485-BD	For RS-485 communication	—	20 mA	—	—
FX5-422-BD-GOT	For RS-422 communication (For GOT connection)	—	20 mA ^{*1}	—	—

*1 When the GOT 5 V type is connected with this product, the current consumption increases.

For the current consumption, refer to the manual of the model to be connected.

3.6 Expansion Adapter

The expansion adapter is to expand functions and is connected on the left side of the CPU module.

For details on the specifications of the expansion adapter, refer to  Hardware manuals of each product.

Model	Function	No. of occupied input/output points	Current consumption		
			5 V DC power supply	24 V DC power supply	External 24 V DC power supply
FX5-232ADP	For RS-232C communication	—	30 mA	30 mA	—
FX5-485ADP	For RS-485 communication	—	20 mA	30 mA	—

3.7 Extension Power Supply Module

The extension power supply module is an added power supply if the built-in power supply of the CPU module is insufficient. For details on the specifications of the extension power supply module, refer to Manuals of each product.

FX5 series

Model	Function	No. of occupied input/output points	Power supply capacity		
			5 V DC power supply	24 V DC power supply	External 24 V DC power supply
FX5-1PSU-5V	Extension power supply	—	1200 mA ^{*1}	300 mA ^{*1}	—

FX3 series

With FX5U series systems, the following extension power supply modules of the FX3 series can be used.

However, a bus conversion module is required to use the intelligent function modules.

For details, refer to Page 42 Bus conversion module.

Model	Function	No. of occupied input/output points	Power supply capacity		
			5 V DC power supply	24 V DC power supply	External 24 V DC power supply
FX3U-1PSU-5V	Extension power supply	—	1000 mA ^{*1}	300 mA ^{*1}	—

*1 If the ambient temperature exceeds 40°C, use the extension power supply module at the following current values within the derating range.

Derating curve

■ FX5-1PSU-5V

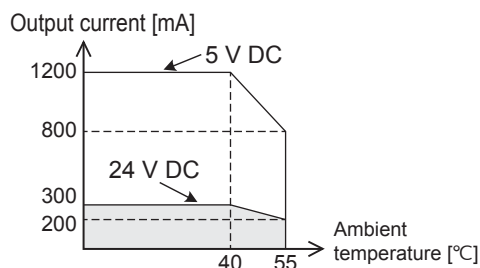

■ FX3U-1PSU-5V

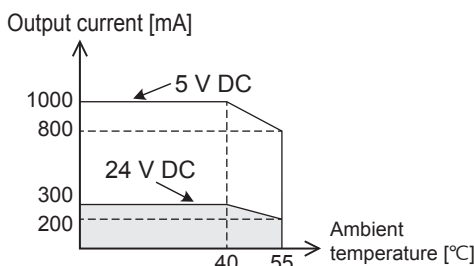

3.8 Bus Conversion Module

The bus conversion module is to connect extension modules of the FX3 series with FX5U series systems. For details on the specifications of the bus conversion module, refer to FX5-CNV-BUS Hardware Manual.

Model	Function	No. of occupied input/output points	Current consumption		
			5 V DC power supply	24 V DC power supply	External 24 V DC power supply
FX5-CNV-BUS	Bus conversion	8 points	150 mA	—	—

3.9 SD Memory Card

For details on the SD memory card, refer to Page 133 SD Memory Card.

Model	Function
L1MEM-2GBSD	SD memory card (Mitsubishi product)
L1MEM-4GBSD	

3.10 Battery

For details on the battery, refer to  Page 112 Battery.

Model	Function
FX3U-32BL	Battery

3.11 Communication Cable

Use a communication cable to connect a PLC with a personal computer by RS-232C communication.

Model	Function
FX-232CAB-1	FX5-232ADP↔Personal computer FX5-232-BD↔Personal computer

3.12 Engineering Tool

For design and programming of FX5U series systems, use GX Works3.

For the operation method, refer to  GX Works3 Operating Manual.

Model	Function
GX Works3	MELSEC PLC software package

4 SYSTEM CONFIGURATION

Configuration of a whole system

The configuration of an entire system is shown below as an example.

Ex.

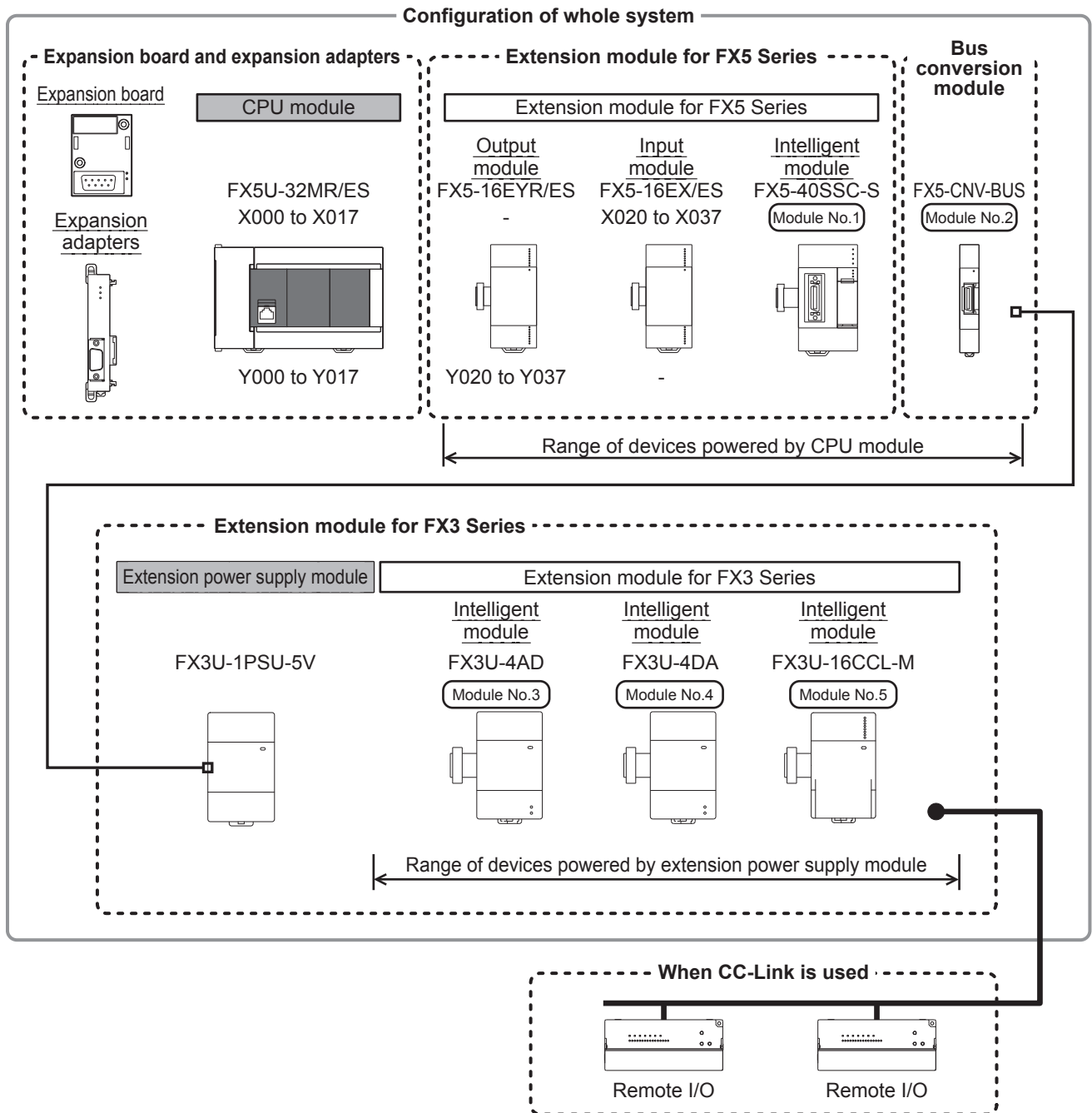

4.1 Rules of System Configuration

The system configuration must meet the following four requirements.

Number of connected extension device

The number of extension devices that can be connected to a single system of FX5U PLCs is limited.

For details, refer to [Page 43](#) Limitations on the Number of Connected Extension Devices.

Ex.

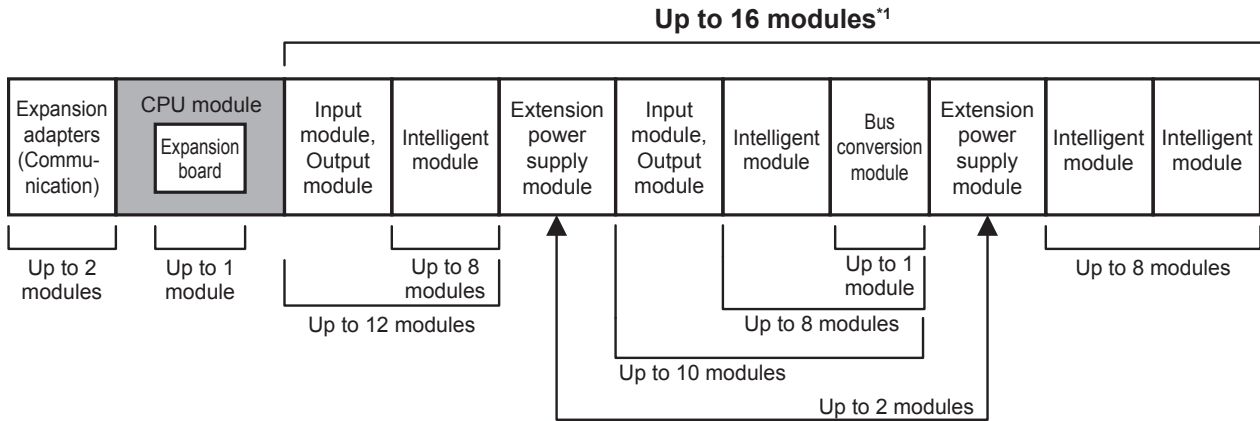

*1 Extension power supply modules are not included in the number of connected devices.

Number of input/output points

With the FX5U PLCs, a total of 512 points or less including the number of input/output points of extension devices (max. 256 points) and number of remote I/O points (max. 384 points) can be controlled.

For details on the number of input/output points, refer to [Page 46](#) Limitation on the Number of Input/Output Points.

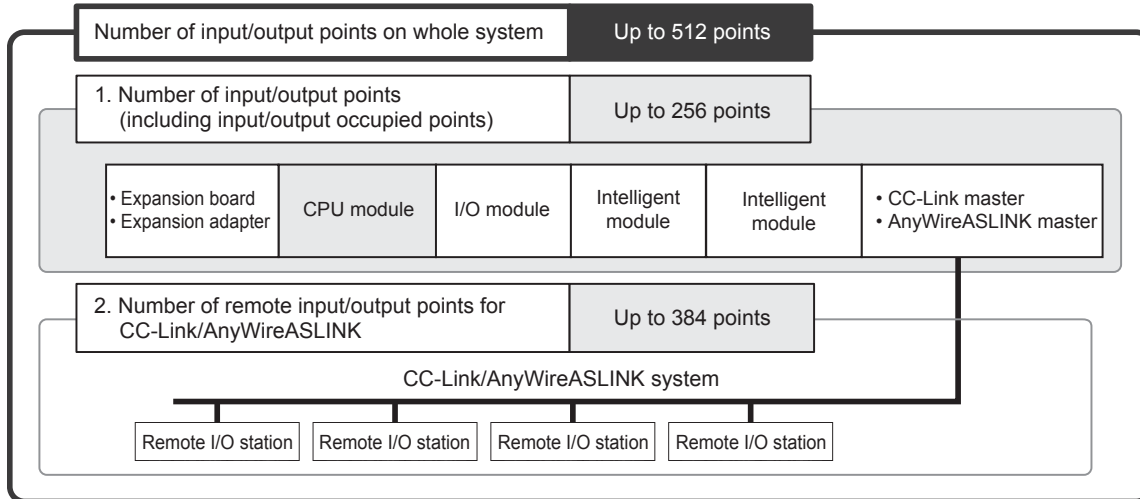

Current consumption

Power of extension devices is supplied from the CPU module or extension power supply module.

The number of extension devices that can be connected must be determined from the capacity of the power supply.

For details on the current consumption, refer to  Page 49 Limitation on Current Consumption.

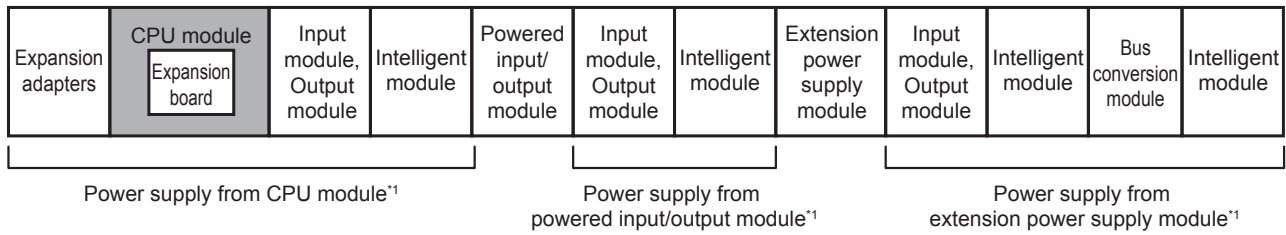

*1 Power is supplied to input circuit of input modules by service power supply or external power supply.

Limitations when using FX3 series extension devices

■Bus conversion module

- A bus conversion module is required to use extension modules of the FX3 series. Extension modules of the FX3 series can be connected to the right side of the bus conversion module only.
- For limitation on the number of connectable modules, refer to  Page 45 Connection to the bus conversion module (connection with FX3 extension devices).
- Extension modules of the FX5 series cannot be connected on the right side of the bus conversion module.

■Limitations on intelligent function modules

Note that some FX3 intelligent function modules have limitations on the number of modules and order in which they are added for each individual module.

Model	Limitations
FX3U-128ASL-M	Only one module may be connected per system.
FX3U-16CCL-M	Only one module may be connected per system.
FX3U-64CCL	Only one module may be connected per system.
FX3U-2HC	Up to two modules connectable per system. When FX5-1PSU-5V is not used, connect immediately after the bus conversion module.

4.2 Limitations on the Number of Connected Extension Devices

Number of connected expansion boards

Only 1 expansion board can be connected on the front face of the CPU module.

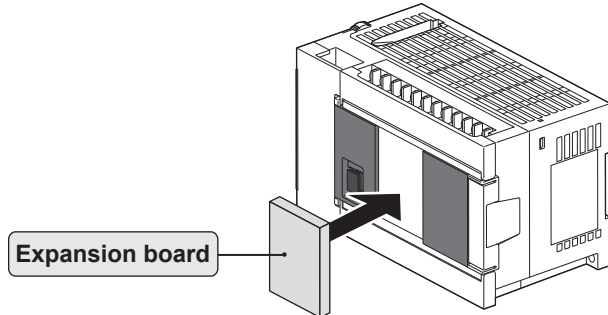

Number of connected expansion adapters

Up to 2 expansion adapters can be connected on the left side of the CPU module.

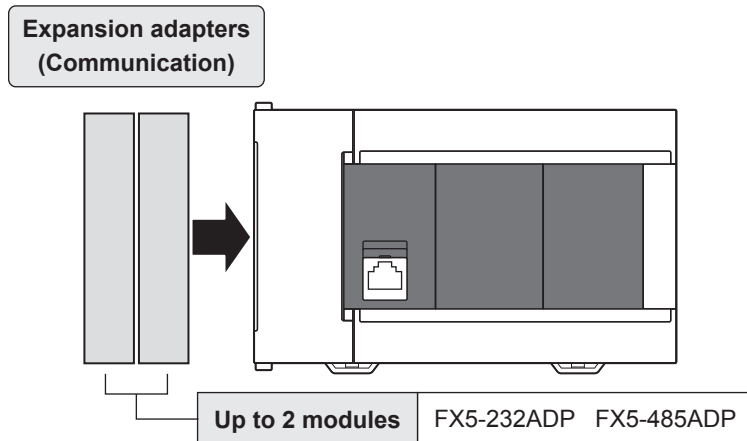

Number of connected extension modules

Overall system limitation

There is a limitation on the number of connected extension modules in a whole system as follows.

Type	Limitations
Extension module	Up to <u>16</u> modules can be connected to a system. (Extension power supply modules are excluded.)
Extension power supply module	Up to <u>2</u> modules can be connected to a system.
Bus conversion module	Only <u>1</u> module can be connected to a system.

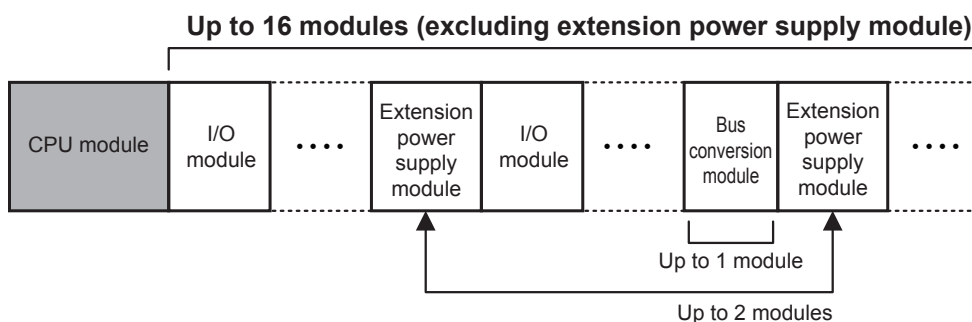

Connection to the CPU module

There is a limitation on the number of extension modules connected to the CPU module as follows.

The number of extension modules added from the right side of the CPU module to powered input/output module or the extension power supply module must be as follows.

Type	Limitations
Total No. of input modules, output modules, intelligent function modules, and bus conversion modules	Up to 12 modules can be connected.
Total No. of intelligent function module and bus conversion modules	Up to 8 modules can be connected.

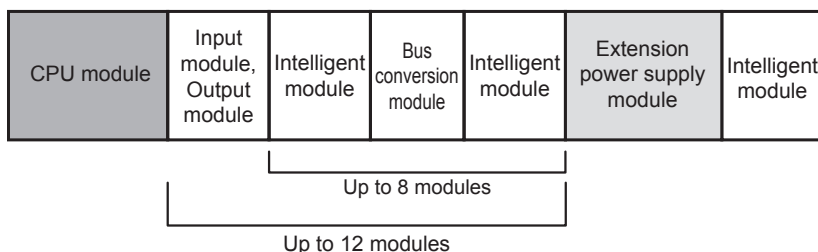
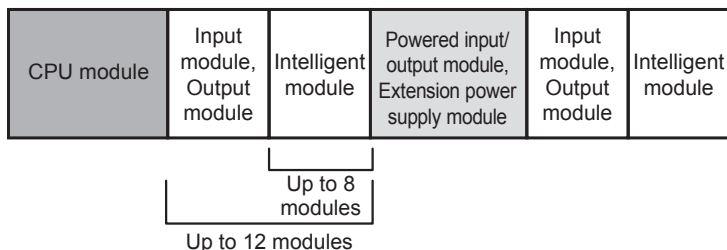

Connection to the powered input/output module

There is a limitation on the number of extension modules connected to the powered input/output module as follows.

The number of connected modules from the right side of the powered input/output module the next extension power supply module added later must be as follows.

Type	Limitations
Total No. of input module, output module intelligent function modules, and bus conversion modules	Up to 10 modules can be connected.
Total No. of intelligent function module and bus conversion modules	Up to 8 modules can be connected.

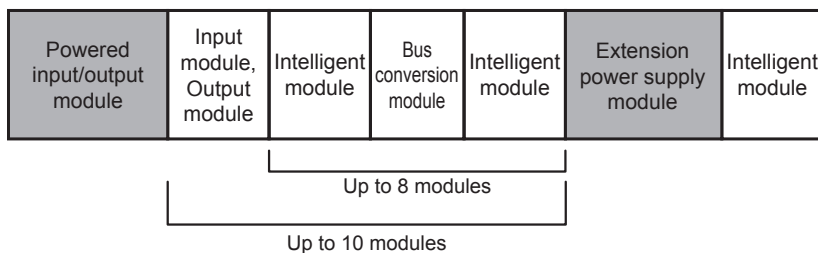
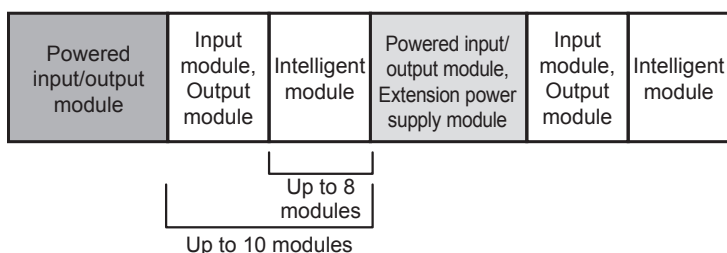

Connection to the extension power supply module (FX5-1PSU-5V)

There is a limitation on the number of extension modules connected to the extension power supply module as follows. The number of connected modules from the right side of the extension power supply module to powered input/output module or the next extension power supply module added later must be as follows.

Type	Limitations
Total No. of input modules, output modules, intelligent function modules, and bus conversion modules	Up to 10 modules can be connected.
Total No. of intelligent function module and bus conversion modules	Up to 8 modules can be connected.

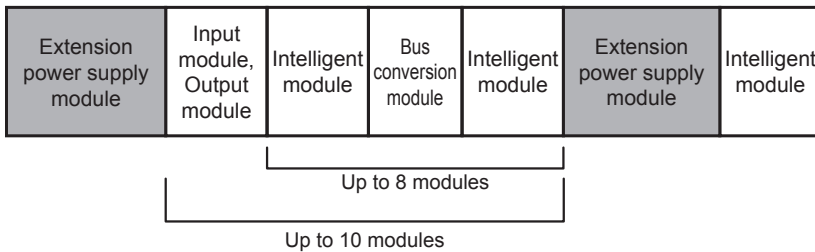
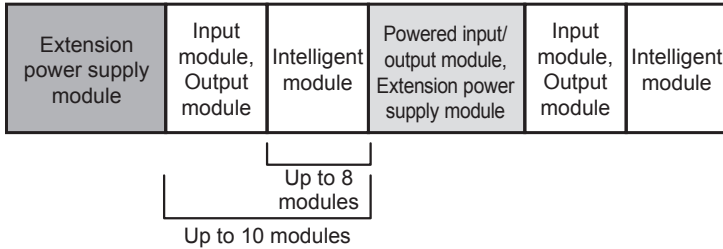

Connection to the bus conversion module (connection with FX3 extension devices)

There is a limitation on the number of extension modules connected to the bus conversion module as follows. The number of modules connected on the right side of the bus conversion module must be as follows.

■When using extension power supply modules

Type	Limitations
Total No. of intelligent function modules	Up to 8 modules can be connected.

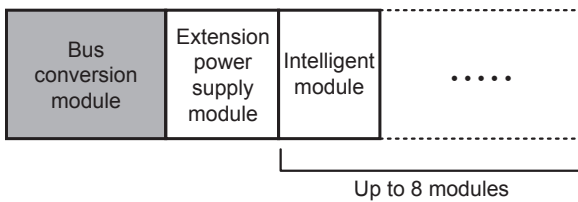

■When not using extension power supply modules

Type	Limitations
Total No. of intelligent function modules	Up to 6 modules can be connected.

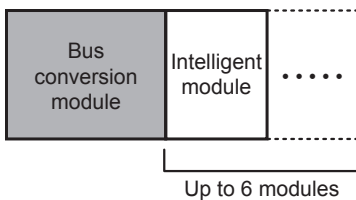

4.3 Limitation on the Number of Input/Output Points

With the FX5U PLCs, a total of 512 points including the number of input/output points of extension devices (max. 256 points) and the number of remote I/O points (max. 384 points) can be controlled.

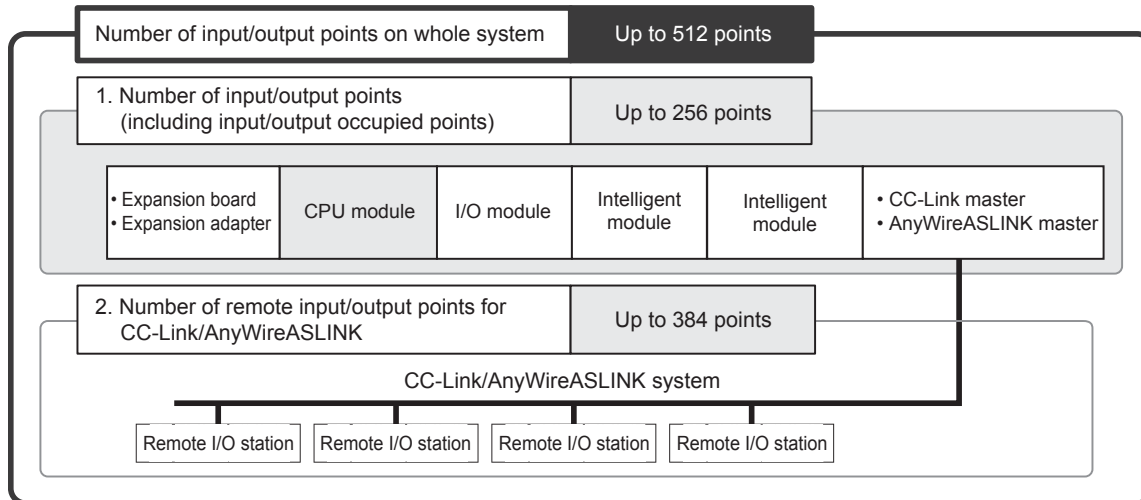

Total number of I/O points and remote I/O points

With the FX5U PLCs, a total of 512 points or less including the number of input/output points of extension devices and number of remote I/O points can be controlled.

The total number of I/O points and remote I/O points must not exceed 512 points.

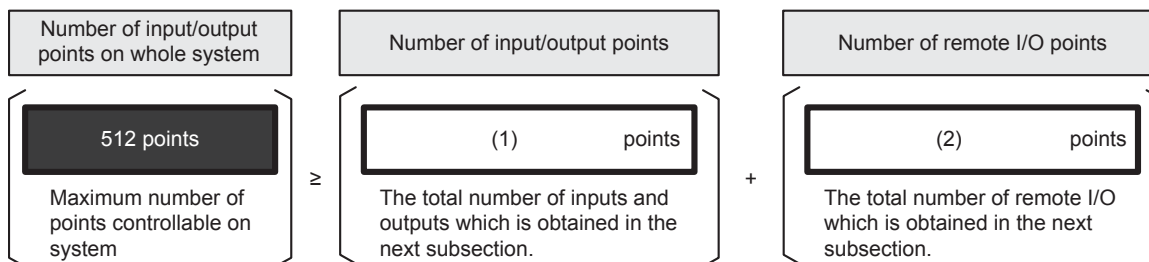

Calculation of number of input/output points

The number of input/output points is the total of the number of input/output points of the CPU module and I/O module, and the number of occupied input/output points of intelligent function modules.

The total number of input/output points must not exceed 256 points.

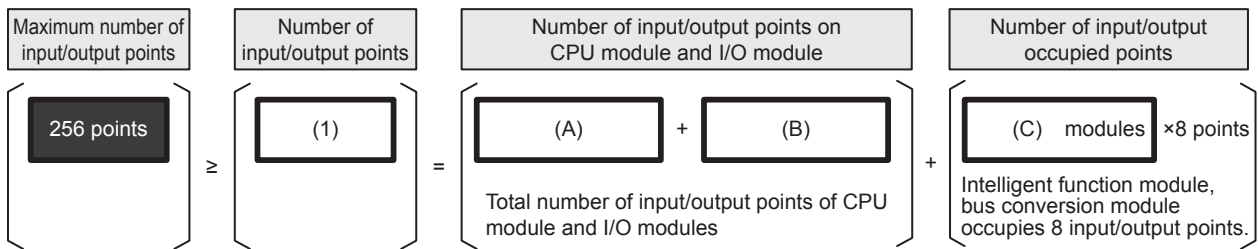

(A): Number of input/output points of CPU module

(B): Number of input/output points of I/O modules

(C): Number of Intelligent function modules

Total number of input/output points of the CPU module and I/O modules

Count the total number of input/output points of the CPU module and I/O modules.

To obtain the total number of input/output points, count the input points (X000 and more) and output points (Y000 and more) of the CPU module and I/O modules.

For details on the number of input/output points by model, refer to the following.

☞ Page 34 CPU Module

☞ Page 35 I/O Module

Number of occupied input/output points of intelligent function modules

Count the number of occupied input/output points of intelligent function modules.

The number of occupied input/output points per module is 8.

For details on the number of occupied input/output points by model, refer to ☞ Page 36 Intelligent Function Module.

Calculation of number of remote I/O points

If the master module of the network is used, calculate the number of remote I/O points connected on the network.
 The total number of remote I/O points must not exceed 384 points.

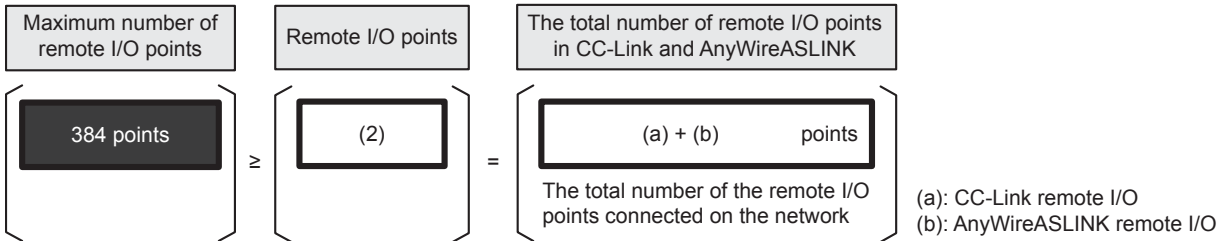

The maximum number of remote I/O points differs according to type of the network.

Precautions

Precautions when using CC-Link master (FX3U-16CCL-M) and AnyWireASLINK master (FX3U-128ASL-M) together
 When using FX3U-16CCL-M and FX3U-128ASL-M together, connect FX3U-128ASL-M on the left side. In the FX5 series, FX3U-16CCL-M parameters are set up by PLC program and will occupy up to 256 remote I/O points. Therefore, the remote I/O points of FX3U-128ASL-M that is connected to the right side may be less than 128 points when FX3U-16CCL-M is connected to the left side.

Ex.

When input/output points are 160 points and CC-Link master are 256 points: 512 points - 160 points - 256 points = 96 points
 Remote I/O points of AnyWireASLINK master are 96 points or less.

CC-Link remote I/O

Remote I/O points that are used in FX3U-16CCL-M are calculated as "number of stations X 32 points."
 Even if using less than 32 remote I/O points, calculate as "number of stations X 32 points."

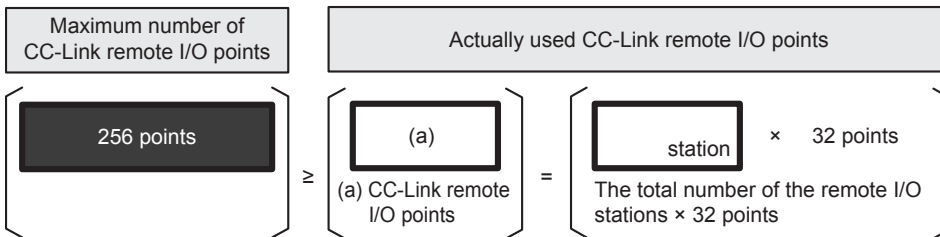

In the FX5 series, FX3U-16CCL-M parameters are set up by PLC program and will occupy up to 256 remote I/O points.
 When the total number of the number of input/output points (including occupied input/output points) and the number of remote I/O points of FX3U-128ASL-M that is connected to the left side exceeds 256 points, the difference of 512 minus that total can be used as CC-Link remote I/O points.

AnyWireASLINK remote I/O

The number of input/output points set by the rotary switch of the AnyWireASLINK master is assigned as remote I/O of AnyWireASLINK.

Use the number of input/output points set by the rotary switch of the AnyWireASLINK master as the number of remote I/O points.

For details, refer to the user's manual of FX3U-128ASL-M.

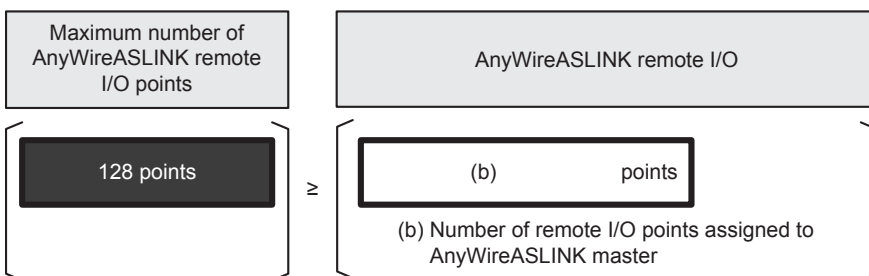

4.4 Limitation on Current Consumption

Power required for expansion adapters, expansion boards, and extension modules is supplied from the CPU module or extension power supply module. The number of extension devices that can be connected must be determined from the capacity of the power supply.

Power supply check from the CPU module (current consumption calculation)

Check if power can be supplied to extension devices with the power supply capacity of the CPU module.

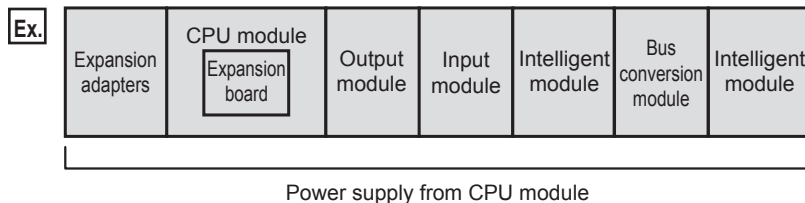

Calculate following the procedure below.

1. Check the power supply capacity of the CPU module used. (☞ Page 34 CPU Module)

Ex.

Type	Model	Power supply capacity	
		5 V DC power supply	24 V DC service power supply
CPU module	FX5U-32MT/ES	900 mA	400 mA ^{*1}

*1 Value when service power supply is used for input circuits. The power supply capacity differs when external power supply is used for input circuit.

2. Check the current consumption of extension devices.
(☞ Page 35 I/O Module), (☞ Page 36 Intelligent Function Module)

Ex.

Type	Model	Current consumption	
		5 V DC power supply	24 V DC power supply
Expansion board	FX5-232-BD	20 mA	—
Expansion adapter	FX5-232ADP	30 mA	30 mA
Output module	FX5-16EYT/ES	100 mA	125 mA
Input module	FX5-16EX/ES	100 mA	85 mA ^{*1}
Simple motion module	FX5-40SSC-S	—	—
Bus conversion module	FX5-CNV-BUS	150 mA	—
Analog input	FX3U-4AD	110 mA	—

*1 If using external power supply for input circuit, calculate current consumption of 24 V DC power supply as 0 mA.

3. Calculate the total current consumption of each power supply.

Ex.

Power supply type	Total current consumption
5 V DC power supply	510 mA
24 V DC power supply	240 mA

4. Check if expansion to the CPU module is permitted.

- 5 V DC power supply

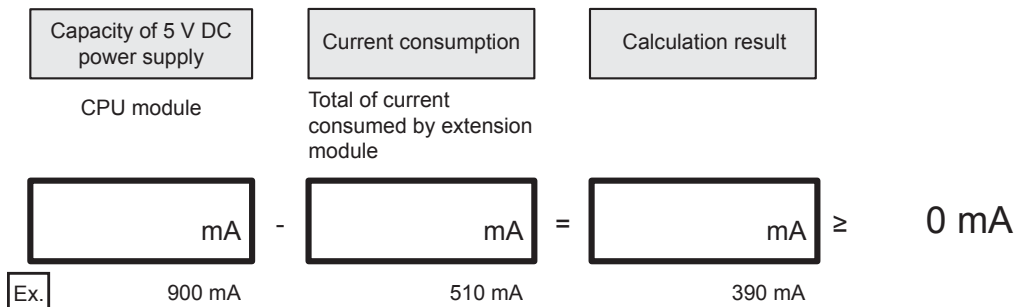

- 24 V DC power supply

The value obtained by this calculation (when the value is positive) indicates the remaining capacity of 24 V DC service power supply, and the capacity can be used for external loads.

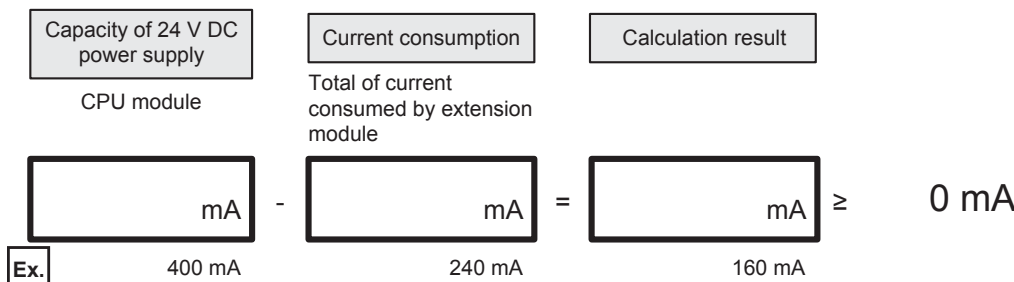

If the calculation result is a negative value, the current consumption exceeds the power supply capacity of the CPU module. Reconfigure the system, adding powered input/output module or extension power supply modules.

Power supply check from the powered input/output module (current consumption calculation)

If 24 V DC and 5 V DC power supplies of the CPU module are insufficient and system cannot be extended, add a powered input/output module.

Check if power can be supplied to extension modules with the power supply capacity of the powered input/output module.

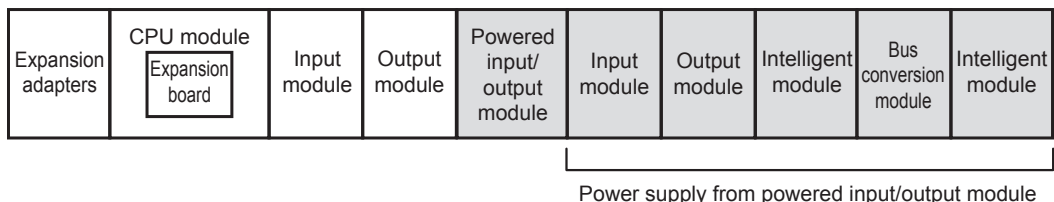

Calculate following the procedure below.

1. Check the power supply capacity of the powered input/output module.

(📖 Page 35 Powered input/output module)

Ex.

Type	Model	Power supply capacity	
		5 V DC power supply	24 V DC service power supply
Powered input/output module	FX5-32ER/ES	965 mA	250 mA ^{*1}

*1 Value when service power supply is used for input circuits. The power supply capacity differs when external power supply is used for input circuit.

2. Check the number of input/output points and current consumption of the extension module.

(☞ Page 35 I/O Module)

(☞ Page 36 Intelligent Function Module)

Ex.

Type	Model	Current consumption	
		5 V DC power supply	24 V DC service power supply
Input module	FX5-16EX/ES	100 mA	85 mA
Output module	FX5-16EYR/ES	100 mA	125 mA
Simple motion modules	FX5-40SSC-S	—	—
Bus conversion module	FX5-CNV-BUS	150 mA	—
Analog input	FX3U-4AD	110 mA	—

3. Calculate the total current consumption of each power supply.

Ex.

Power supply type	Total current consumption
5 V DC power supply	460 mA
24 V DC power supply	210 mA

4. Check if expansion to the extension power supply module is permitted.

• 5 V DC power supply

Capacity of 5 V DC power supply	Current consumption	Calculation result	
Powered input/output module	Total of current consumed by extension module		
<div style="border: 1px solid black; width: 100px; height: 30px; margin: 0 auto;"></div> mA	<div style="border: 1px solid black; width: 100px; height: 30px; margin: 0 auto;"></div> mA	<div style="border: 1px solid black; width: 100px; height: 30px; margin: 0 auto;"></div> mA	$\geq 0 \text{ mA}$

Ex.

965 mA 460 mA 505 mA

• 24 V DC power supply

The value obtained by this calculation (when the value is positive) indicates the remaining capacity of 24 V DC service power supply, and the capacity can be used for external loads.

Capacity of 24 V DC service power supply	Current consumption	Calculation result	
Powered input/output module	Total of current consumed by extension module		
<div style="border: 1px solid black; width: 100px; height: 30px; margin: 0 auto;"></div> mA	<div style="border: 1px solid black; width: 100px; height: 30px; margin: 0 auto;"></div> mA	<div style="border: 1px solid black; width: 100px; height: 30px; margin: 0 auto;"></div> mA	$\geq 0 \text{ mA}$

Ex.

250 mA 210 mA 40 mA

Power supply check from extension power supply module (current consumption calculation)

If 5 V DC power supply of the CPU module is insufficient and cannot be extended, add an extension power supply module. Check if power can be supplied to extension modules with the power supply capacity of the extension power supply module.

Ex.

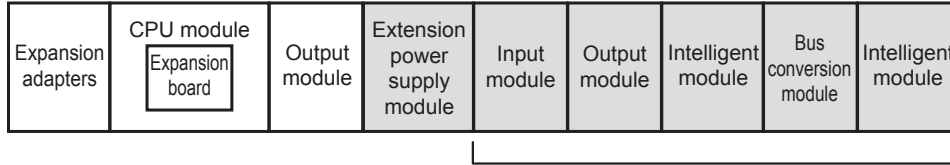

Power supply from extension power supply module
(Only the 5 V DC power supply for the input module is supplied by the extension power supply module.)

Calculate following the procedure below.

1. Check the power supply capacity of the extension power supply module used.

(☞ Page 38 Extension Power Supply Module)

Ex.

Type	Model	Power supply capacity	
		5 V DC power supply	24 V DC power supply
Extension power supply module	FX5-1PSU-5V	1200 mA	300 mA

Point

If the ambient temperature exceeds 40°C, use the extension power supply module at the following current values within the derating range.

Derating curve

■FX5-1PSU-5V

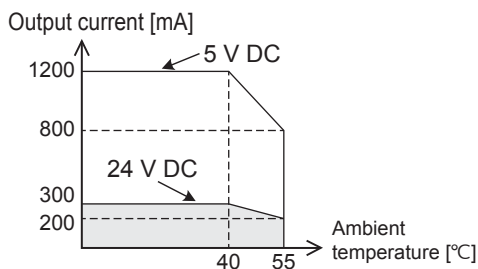

2. Check the number of input/output points and current consumption of the extension module.

(☞ Page 35 I/O Module)

(☞ Page 36 Intelligent Function Module)

Ex.

Type	Model	Current consumption	
		5 V DC power supply	24 V DC power supply
Input module	FX5-16EX/ES	100 mA	—*1
Output module	FX5-16EYR/ES	100 mA	125 mA
Simple motion module	FX5-40SSC-S	—	—
Bus conversion module	FX5-CNV-BUS	150 mA	—
Analog input	FX3U-4AD	110 mA	—

*1 24 V DC power supply is supplied from the CPU module or powered input/output module.

Point

When connecting an input module after (on the right side of) the extension power supply module
 When using service power supply of the CPU module or powered input/output module for input circuit of an input module, include the input module in the 24 V DC current consumption calculation.
 5 V DC power supply of the input module is supplied from the extension power supply module.

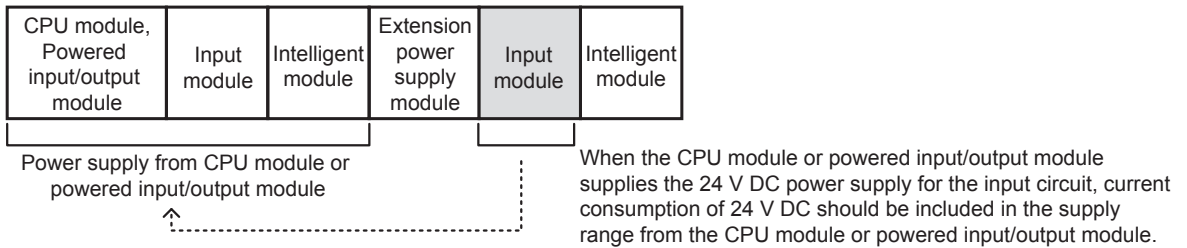

3. Calculate the total current consumption of each power supply.

Ex.

Power supply type	Total current consumption
5 V DC power supply	460 mA
24 V DC power supply	125 mA

4. Check if expansion to the extension power supply module is permitted.

• 5 V DC power supply

Capacity of 5 V DC power supply Extension power supply module	Current consumption Total of current consumed by extension module	Calculation result
<input type="text" value="1200"/> mA	<input type="text" value="460"/> mA	<input type="text" value="740"/> mA

$1200 \text{ mA} - 460 \text{ mA} = 740 \text{ mA} \geq 0 \text{ mA}$

Ex.

• 24 V DC power supply

Capacity of 24 V DC power supply Extension power supply module	Current consumption Total of current consumed by extension module	Calculation result
<input type="text" value="300"/> mA	<input type="text" value="125"/> mA	<input type="text" value="175"/> mA

$300 \text{ mA} - 125 \text{ mA} = 175 \text{ mA} \geq 0 \text{ mA}$

Ex.

If the calculation result is a negative value, the current consumption exceeds the power supply capacity of the extension power supply module.

Reconfigure the system, adding powered input/output module or extension power supply modules.

4.5 Rules of System Configuration and Examples of Reconfiguration

The rules of system configuration are explained below referring to a sample system configuration using an expansion board, expansion adapter, I/O module, and intelligent function module.

System configuration example

The following system configuration is under consideration.

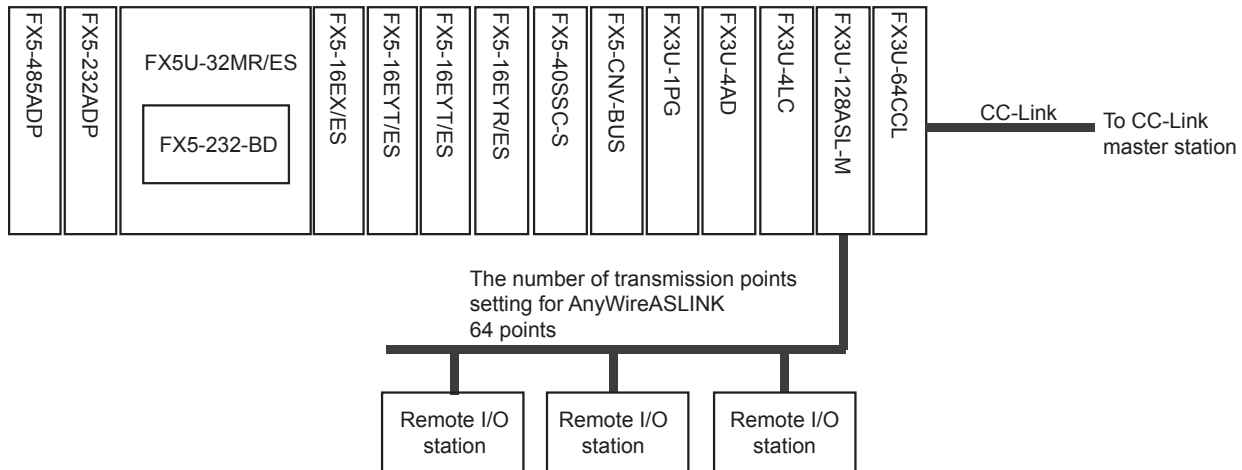

Check of limitation on the number of modules

Check if the sample system configuration is within the connectable-module range.

■Number of connected expansion boards

(☞ Page 43 Number of connected expansion boards)

Type	No. of modules used	Limitations	Judgment
Expansion board	1	Only 1	OK

■Number of connected expansion adapters

(☞ Page 43 Number of connected expansion adapters)

Type	No. of modules used	Limitations	Judgment
Expansion adapter	2	Up to 2	OK

■Number of connected extension modules

• Number of modules connected on whole system

(☞ Page 43 Overall system limitation)

Type	No. of modules used	Limitations	Judgment
Extension module	11	Up to 16 (Extension power supply modules are excluded.)	OK
Extension power supply module	Not used	Up to 2	OK
Bus conversion module	1	Only 1	OK

- Number of modules connected to the CPU module

(☞ Page 44 Connection to the CPU module)

Type	No. of modules used	Limitations	Judgment
Total No. of I/O modules, intelligent function modules, and bus conversion modules	11	Up to 12	OK
Total No. of intelligent function module and bus conversion modules	7	Up to 8	OK

- Number of modules connected to the bus conversion module

(☞ Page 45 Connection to the bus conversion module (connection with FX3 extension devices))

Type	No. of modules used	Limitations	Judgment
Total No. of intelligent function modules	5	Up to 6 (When not using extension power supply modules)	OK

Check on limitations when using FX3 series extension devices

Check the use of the FX3 series extension devices.

■Use of the bus conversion module

(☞ Page 42 Bus conversion module)

Limitations	Judgment
Extension modules of the FX3 series are connected on the right side of the bus conversion module.	OK
Extension modules of the FX5 series are connected on the left side of the bus conversion module.	OK

■Connection of intelligent function modules

(☞ Page 42 Limitations on intelligent function modules)

Model	Limitations	Judgment
FX3U-128ASL-M	Only one module may be connected to the system.	OK
FX3U-64CCL	Only one module may be connected to the system.	OK

Check of limitation on the number of input/output points

Check if the number of input/output points of the sample system configuration is within the limit range.

■Number of input/output points

(☞ Page 47 Calculation of number of input/output points)

Type	Model	No. of input/output points	No. of occupied input/output points
CPU module	FX5-32MR/ES	32 points	—
Expansion board	FX5-232-BD	—	—
Expansion adapter	FX5-232ADP	—	—
Expansion adapter	FX5-485ADP	—	—
Input module	FX5-16EX/ES	16 points	—
Output module	FX5-16EYT/ES	16 points	—
Output module	FX5-16EYT/ES	16 points	—
Output module	FX5-16EYR/ES	16 points	—
Simple motion module	FX5-40SSC-S	—	8 points
Bus conversion module	FX5-CNV-BUS	—	8 points
Pulse output module	FX3U-1PG	—	8 points
Analog input module	FX3U-4AD	—	8 points
Temperature controller module	FX3U-4LC	—	8 points
AnyWireASLINK master module	FX3U-128ASL-M	—	8 points
CC-Link intelligent device module	FX3U-64CCL	—	8 points

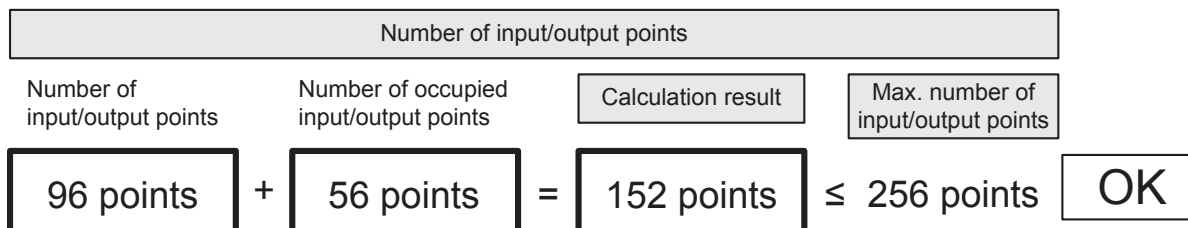

■Number of remote I/O points

(☞ Page 48 Calculation of number of remote I/O points)

Network	No. of remote I/O points
AnyWireASLINK	64 points

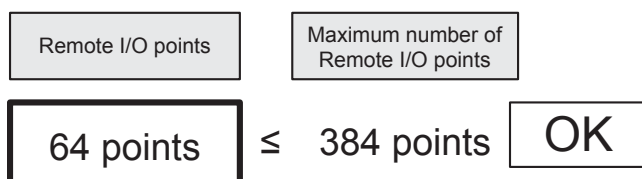

■Total number of I/O points and remote I/O points

(☞ Page 46 Limitation on the Number of Input/Output Points)

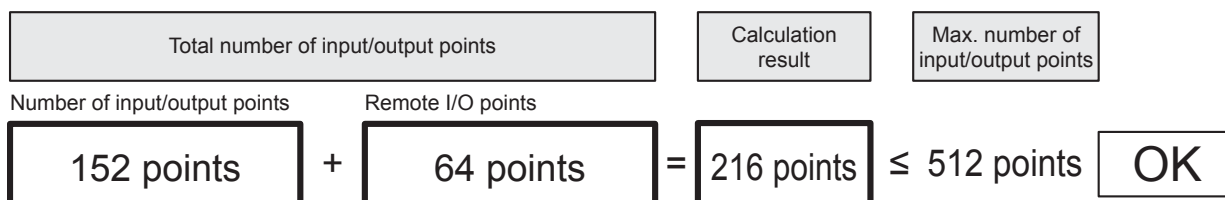

Check of limitation on current consumption

Check if power required for extension devices can be supplied from the CPU module and extension power supply module. A case using service power supply for input circuit is explained as an example.

■ Check of power supply from the CPU module

(☞ Page 49 Power supply check from the CPU module (current consumption calculation))

- Power supply capacity of the CPU module

Type	Model	Power supply capacity	
		5 V DC power supply	24 V DC service power supply
CPU module	FX5U-32MR/ES	900 mA	400 mA (Service power supply is used for input circuit)

- Current consumption of extension devices

Type	Model	Current consumption	
		5 V DC power supply	24 V DC power supply
Expansion board	FX5-232-BD	20 mA	—
Expansion adapter	FX5-232ADP	30 mA	30 mA
Expansion adapter	FX5-485ADP	20 mA	30 mA
Input module	FX5-16EX/ES	100 mA	85 mA
Output module	FX5-16EYT/ES	100 mA	125 mA
Output module	FX5-16EYT/ES	100 mA	125 mA
Output module	FX5-16EYR/ES	100 mA	125 mA
Simple motion module	FX5-40SSC-S	—	—
Bus conversion module	FX5-CNV-BUS	150 mA	—
Pulse output module	FX3U-1PG	150 mA	—
Analog input module	FX3U-4AD	110 mA	—
Temperature controller module	FX3U-4LC	160 mA	—
AnyWireASLINK master module	FX3U-128ASL-M	130 mA	—
CC-Link intelligent device module	FX3U-64CCL	—	—

Capacity of 5 V DC power supply CPU module	Current consumption Total of current consumed by extension module	Calculation result	
900 mA	- 1170 mA	= -270 mA	NG
Capacity of 24 V DC power supply CPU module	Current consumption Total of current consumed by extension module	Calculation result	
400 mA	- 520 mA	= -120 mA	NG

Result check

Because calculation results for 5 V DC or 24 V DC current consumption are negative, reconfiguration is necessary. The judgment procedure after reconfiguration is explained on the following pages.

System reconfiguration example

If current consumption of the 5 V DC or 24 V DC power supply is insufficient with the CPU module only, powered input/output module or use an extension power supply module.

Reconfigure the example system configuration using an extension power supply module.

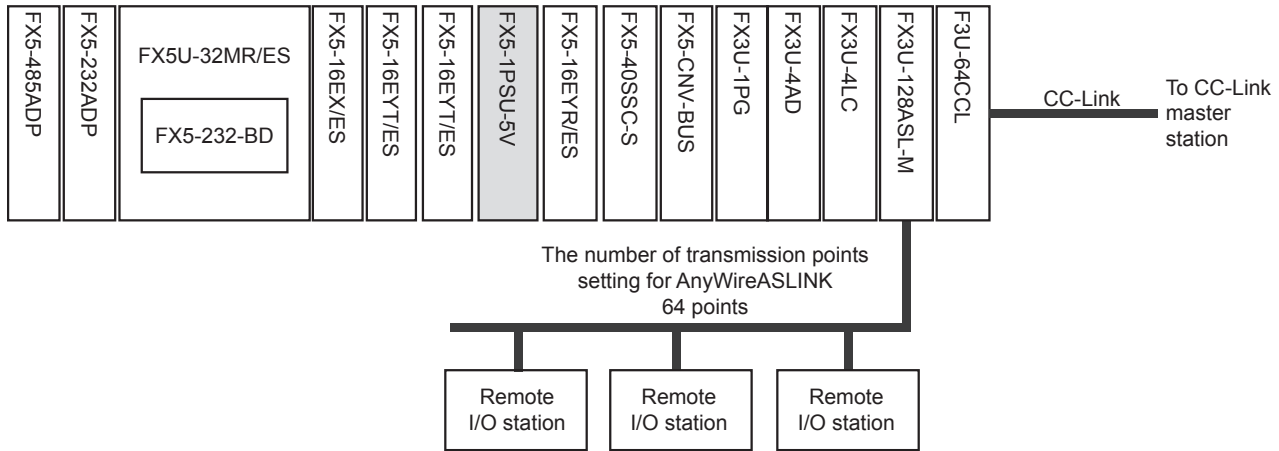

Check of limitation on the number of modules

Check if the example system configuration is within the connectable-module range.

■Number of connected expansion boards

(☞ Page 43 Number of connected expansion boards)

Type	No. of modules used	Limitations	Judgment
Expansion board	1	Only 1	OK

■Number of connected expansion adapters

(☞ Page 43 Number of connected expansion adapters)

Type	No. of modules used	Limitations	Judgment
Expansion adapter	2	Up to 2	OK

■Number of connected extension modules

- Number of modules connected on whole system

(☞ Page 43 Overall system limitation)

Type	No. of modules used	Limitations	Judgment
Extension module	11	Up to 16 (Extension power supply modules are excluded.)	OK
Extension power supply module	1	Up to 2	OK
Bus conversion module	1	Only 1	OK

- Number of modules connected to the CPU module

(☞ Page 44 Connection to the CPU module)

Type	No. of modules used	Limitations	Judgment
Total No. of I/O modules, intelligent function modules, and bus conversion modules	3	Up to 12	OK
Total No. of intelligent function module and bus conversion modules	0	Up to 8	OK

- Number of modules connected to extension power supply module

(☞ Page 45 Connection to the extension power supply module (FX5-1PSU-5V))

Type	No. of modules used	Limitations	Judgment
Total No. of I/O modules, intelligent function modules, and bus conversion modules	8	Up to 10	OK
Total No. of intelligent function module and bus conversion modules	7	Up to 8	OK

- Number of modules connected to the bus conversion module

(☞ Page 45 Connection to the bus conversion module (connection with FX3 extension devices))

Type	No. of modules used	Limitations	Judgment
Total No. of intelligent function modules	5	Up to 6 (When not using extension power supply modules)	OK

Check on limitations when using FX3 series extension devices

Check on limitations when using the FX3 series extension devices.

■Use of the bus conversion module

(☞ Page 42 Bus conversion module)

Limitations	Judgment
Extension modules of the FX3 series are connected on the right side of the bus conversion module.	OK
Extension modules of the FX5 series are connected on the left side of the bus conversion module.	OK

■Connection of intelligent function modules

(☞ Page 42 Limitations on intelligent function modules)

Model	Limitations	Judgment
FX3U-128ASL-M	Only one module may be connected to the system.	OK
FX3U-64CCL	Only one module may be connected to the system.	OK

Check of limitation on the number of input/output points

Check if the number of input/output points of the sample system configuration is within the limit range.

■Number of input/output points

(☞ Page 47 Calculation of number of input/output points)

Type	Model	No. of input/output points	No. of occupied input/output points
CPU module	FX5-32MR/ES	32 points	
Input module	FX5-16EX/ES	16 points	—
Output module	FX5-16EYT/ES	16 points	—
Output module	FX5-16EYT/ES	16 points	—
Extension power supply module	FX5-1PSU-5V	—	—
Output module	FX5-16EYR/ES	16 points	—
Simple motion module	FX5-40SSC-S	—	8 points
Bus conversion module	FX5-CNV-BUS	—	8 points
Pulse output module	FX3U-1PG	—	8 points
Analog input module	FX3U-4AD	—	8 points
Temperature controller module	FX3U-4LC	—	8 points
AnyWireASLINK master module	FX3U-128ASL-M	—	8 points
CC-Link intelligent device module	FX3U-64CCL	—	8 points

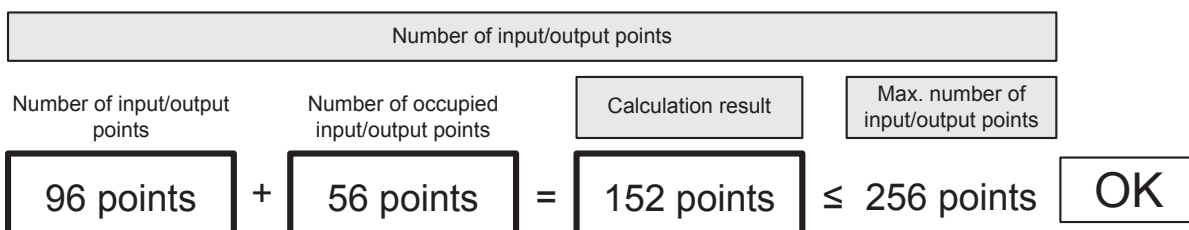

■Number of remote I/O points

(☞ Page 48 Calculation of number of remote I/O points)

Network	No. of remote I/O points
AnyWireASLINK	64 points

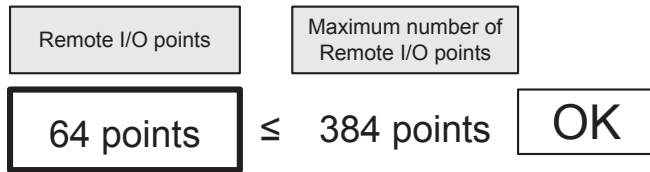

■Total number of I/O points and remote I/O points

(☞ Page 46 Limitation on the Number of Input/Output Points)

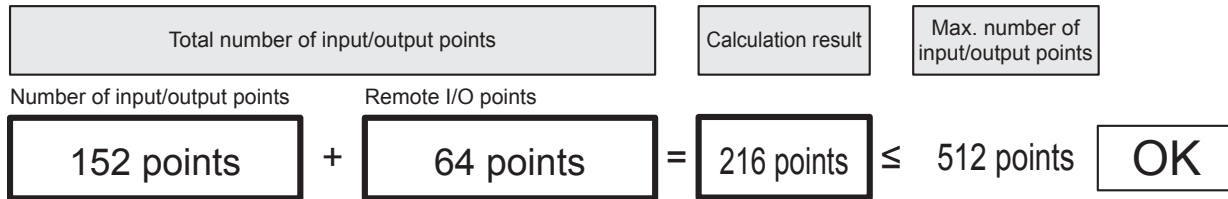

Check of limitation on current consumption

Check if power required for extension devices can be supplied from the CPU module and extension power supply module. A case using service power supply for input circuit is explained as an example.

■ Check of power supply from the CPU module

(☞ Page 49 Power supply check from the CPU module (current consumption calculation))

Power supply capacity of the CPU module

Type	Model	Power supply capacity	
		5 V DC power supply	24 V DC service power supply
CPU module	FX5U-32MR/ES	900 mA	400 mA (Service power supply is used for input circuit)

Current consumption of extension devices

Type	Model	Current consumption	
		5 V DC power supply	24 V DC power supply
Expansion board	FX5-232-BD	20 mA	—
Expansion adapter	FX5-232ADP	30 mA	30 mA
Expansion adapter	FX5-485ADP	20 mA	30 mA
Input module	FX5-16EX/ES	100 mA	85 mA
Output module	FX5-16EYT/ES	100 mA	125 mA
Output module	FX5-16EYT/ES	100 mA	125 mA

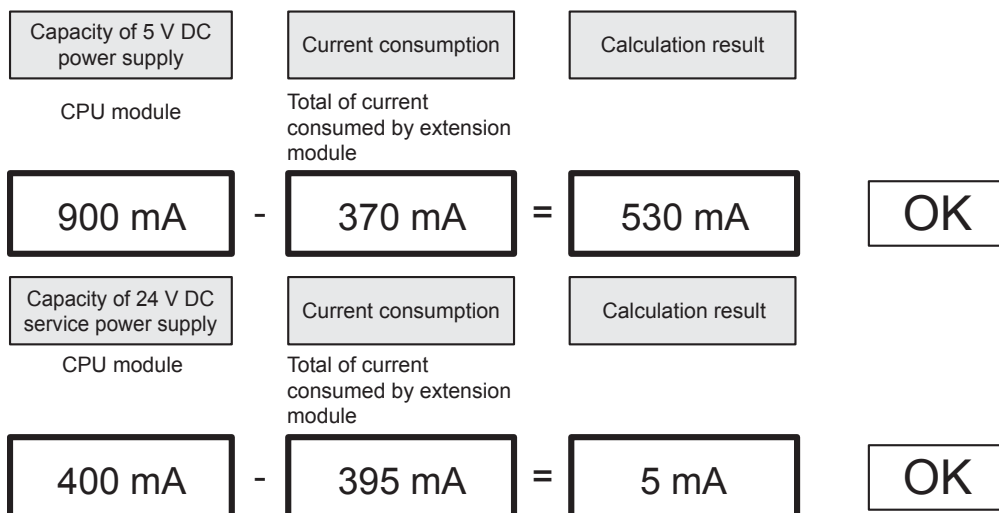

■ Check of power supply from the extension power supply module

(☞ Page 52 Power supply check from extension power supply module (current consumption calculation))

Power supply capacity of the extension power supply module

Type	Model	Power supply capacity	
		5 V DC power supply	24 V DC power supply
Extension power supply module	FX5-1PSU-5V	1200 mA	300 mA

Current consumption of extension devices

Type	Model	Current consumption	
		5 V DC power supply	24 V DC power supply
Output module	FX5-16EYR/ES	100 mA	125 mA
Simple motion module	FX5-40SSC-S	—	—
Bus conversion module	FX5-CNV-BUS	150 mA	—
Pulse output module	FX3U-1PG	150 mA	—
Analog input module	FX3U-4AD	110 mA	—
Temperature controller module	FX3U-4LC	160 mA	—
AnyWireASLINK master module	FX3U-128ASL-M	130 mA	—
CC-Link intelligent device module	FX3U-64CCL	—	—

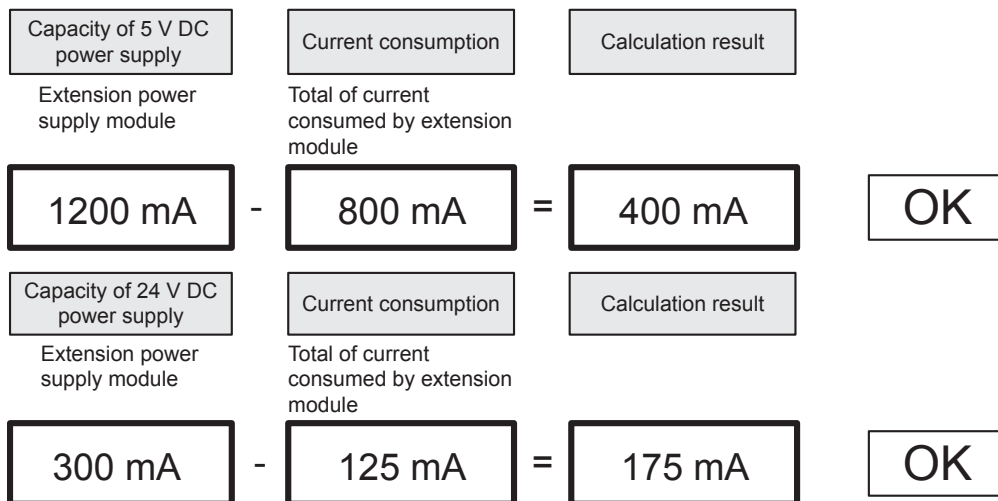

Result check

The reconfigured system is acceptable because the number of extension devices, consumption capacity of 5 V DC and 24 V DC power supply, and number of input/output points are all within the limit range.

4.6 Numbers and Assignment in System

Input/output numbers and module numbers in an FX5 series system are explained.

Module input/output number

The input/output numbers are octal numbers. Input is assigned to "X" and output to "Y."

Input/output numbers are used for communication of ON/OFF data between I/O modules and the CPU module.

- Input/output numbers (X/Y) are octal.

Input/output numbers (X/Y) are automatically assigned as shown below.

X000 to X007, X010 to X017, X020 to X027, ... X070 to X077, X100 to X107, ...

Y000 to Y007, Y010 to Y017, Y020 to Y027, ... Y070 to Y077, Y100 to Y107, ...

- Numbers for added I/O module

To an added I/O module, input numbers and output numbers following the input numbers and output numbers given to the preceding device are assigned. The last digit of the assigned numbers must begin with 0.

Module number of Extension modules

The CPU module automatically assigns numbers (1 to 16) to intelligent function modules or bus conversion module as module numbers in order of distance from the CPU module.

- Intelligent function modules or bus conversion module connected to the CPU module

Module numbers are assigned to intelligent function modules in order of distance from the CPU module: No. 1 to No. 16.

- Products to which module numbers are not assigned

Module numbers are not assigned to the following extension devices.

- I/O module FX5-16EX/ES, FX5-16EYT/ES, etc.
- Expansion board FX5-232-BD, FX5-485-BD, etc.
- Expansion adapter FX5-232ADP, FX5-485ADP, etc.
- Extension power supply module FX5-1PSU-5V, FX3U-1PSU-5V

Ex.

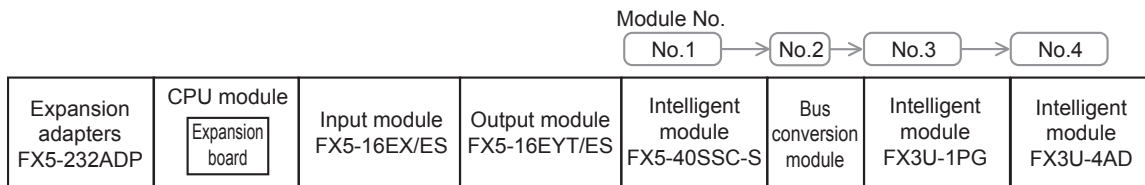

5 INSTALLATION

5.1 Installation Location

Use the PLC under the environmental conditions complying with the generic specifications (Page 19 Generic Specifications).

Installation location in enclosure

To prevent temperature rise, do not mount the PLC on the floor or ceiling, or in the vertical direction. Always mount the PLC horizontally on the wall as shown in the following figure.

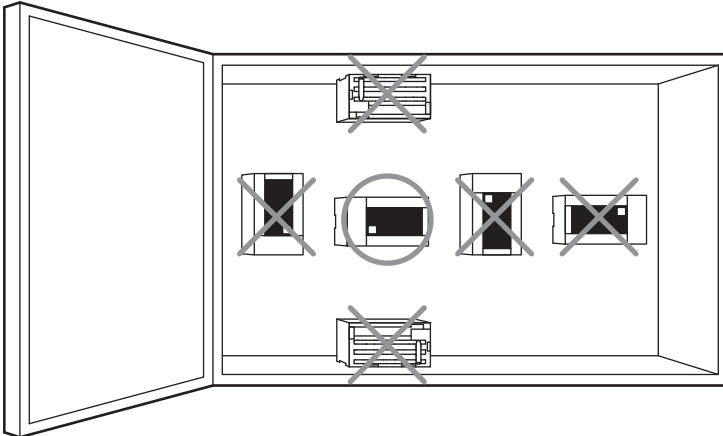

Spaces in enclosure

Extension devices can be connected on the left and right sides of the CPU module of the PLC. Keep a space of at least 50 mm (1.97") between the module main body and other devices and structure.

If you intend to add extension devices, keep necessary spaces on the left and right sides.

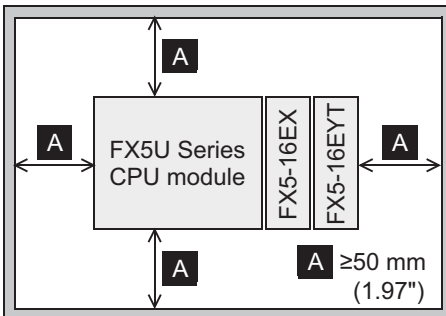

Layout in enclosure

Keep a space of at least 50 mm (1.97") between the module main body or other devices and structure.

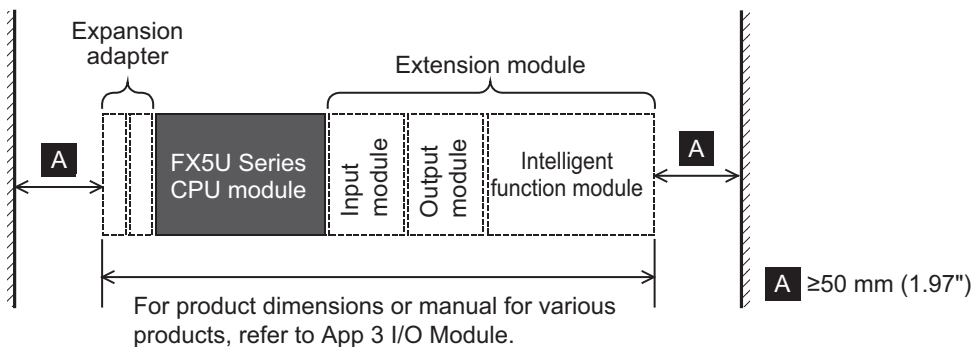

5.2 Examination for Installation Method in Enclosure

Examine the installation location of PLC considering the environmental conditions (☞ Page 19 Generic Specifications). The PLC can be installed by the following two methods.

Point 

Keep a space of about 2 mm (0.08") between the products.

Installing on DIN rail

- The PLC can be installed on a DIN46277 rail (35 mm (1.38") wide).
- The PLC can be easily moved and removed.
- The PLC installation height is the same as the DIN rail.

For details on the procedures for installing on and detaching from DIN rail, refer to ☞ Page 66 Procedures for Installing on and Detaching from DIN Rail.

■ Example of installation

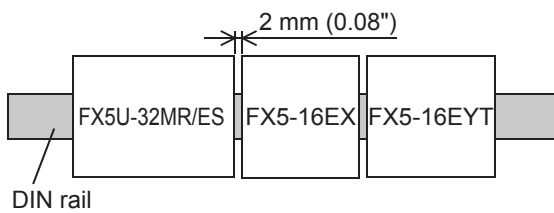

Installing directly

- The PLC can be installed directly in the enclosure with M4 screws.

For mounting hole pitch, refer to ☞ Page 68 Hole pitches for direct mounting.

■ Example of installation

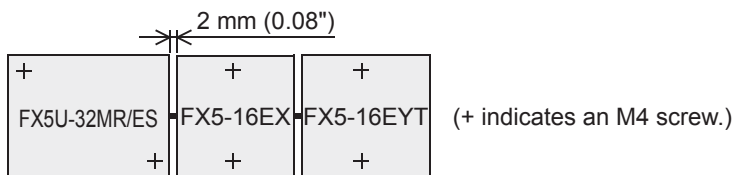

5.3 Procedures for Installing on and Detaching from DIN Rail

The CPU module can be installed on a DIN46277 rail (35 mm (1.38") wide).

Preparation for installation

Connecting extension devices

Some extension devices must be mounted on the CPU module before the module is installed in the enclosure.

- Connect expansion adapters to the CPU module before mounting the PLC in the enclosure.
- Mount extension modules in the enclosure after mounting the CPU module in the enclosure.
- Expansion boards can be mounted on the CPU module after it is installed in the enclosure.
- Batteries can be replaced without dismounting the CPU module from the enclosure. However, if an expansion board is used, the CPU module must be removed.

Affixing the dust proof sheet

The dust proof sheet should be affixed to the ventilation slits before beginning the installation and wiring work.

For the affixing procedure, refer to the instructions on the dust proof sheet.

Always remove the dust proof sheet when the installation and wiring work is completed.

Installation of CPU module

Connect the expansion adapter to the CPU module before mounting the PLC in the enclosure.

For the connection method of the expansion adapter, refer to [Page 73 Connection method B - connection of an expansion adapter](#).

1. Push out all DIN rail mounting hooks (A in the following figure).

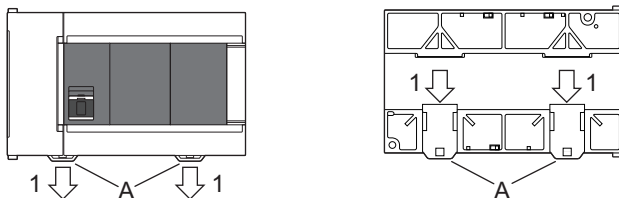

2. Fit the upper edge of the DIN rail mounting groove (B in the following figure) onto the DIN rail.

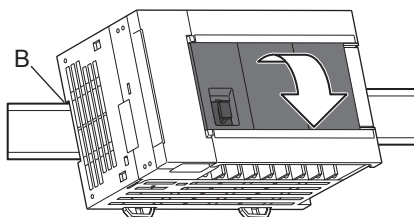

3. Lock the DIN rail mounting hooks (C in the following figure) while pressing the PLC against the DIN rail.

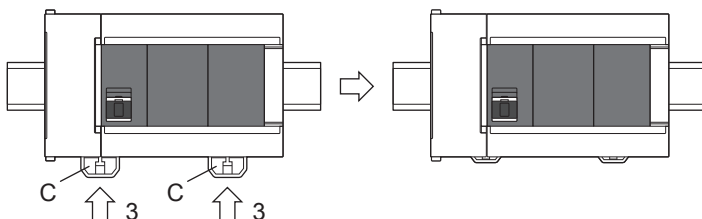

Installation of extension module

1. Push out the DIN rail mounting hook (A in the right figure) of the extension module.

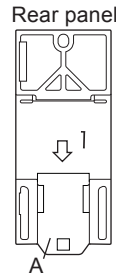

2. Fit the upper edge of the DIN rail mounting groove (B in the right figure) onto the DIN rail.
3. Push the product against the DIN rail.
4. Lock the DIN rail mounting hook while pressing the product against the DIN rail.

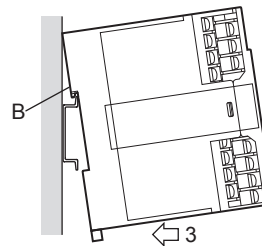

5. Connect the extension cable. For the connecting procedure of the extension cable, refer to [Page 72 Connection Methods for CPU Module and Extension Devices](#).

Removal of CPU module

1. Open the terminal block cover, gradually loosen the left and right terminal block mounting screws (A in the right figure), and remove the terminal blocks. For the mounting procedure of the terminal block, refer to [Page 76 Removal and installation of removable terminal block](#).

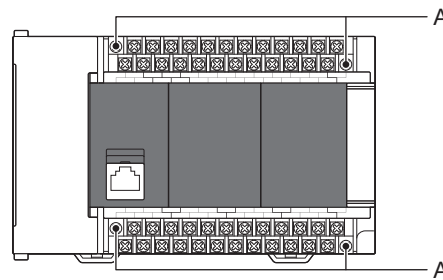

2. Disconnect the extension cables and the connecting cables. When removing the extension cable, pull the pullout tab of the extension cable straight up.
3. Insert the tip of a flathead screwdriver into the hole of the DIN rail mounting hook (B in the right figure). This step also applies for the DIN rail mounting hooks of the expansion adapters.
4. Move the flathead screwdriver as shown in the right figure to draw out the DIN rail mounting hooks of all devices.
5. Remove the product from the DIN rail (C in the right figure).
6. Push in the DIN rail mounting hooks (D in the right figure).

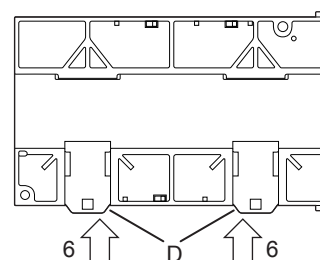
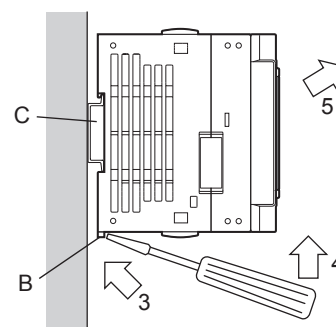

5.4 Procedures for Installing Directly (with M4 Screws)

The product can be installed directly in the enclosure (with screws).



Position the holes so that there is a gap of about 2 mm (0.08") between the products.

Hole pitches for direct mounting

The product mounting hole pitches are shown below.
For pitch that varies depending on the product, refer to the table.

CPU module

Dimensions	Model name	Mounting hole pitch W Unit: mm (inches)
	FX5U-32MR/ES FX5U-32MT/ES FX5U-32MT/ESS	123 (4.85")
	FX5U-64MR/ES FX5U-64MT/ES FX5U-64MT/ESS FX5U-80MR/ES FX5U-80MT/ES FX5U-80MT/ESS	193 (7.6") 258 (10.16")

Expansion adapter

Dimensions	Model name	Mounting hole pitch W Unit: mm (inches)
	FX5-232ADP FX5-485ADP	15.1 (0.6")

I/O module

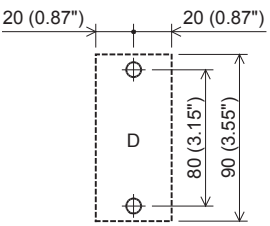
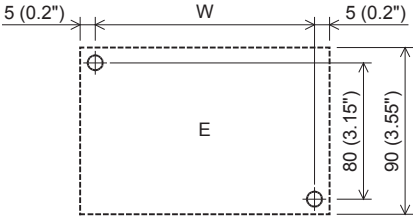
Dimensions	Model name	Mounting hole pitch W Unit: mm (inches)
	FX5-8EX/ES FX5-8EYR/ES FX5-8EYT/ES FX5-8EYT/ESS FX5-16EX/ES FX5-16EYR/ES FX5-16EYT/ES FX5-16EYT/ESS	Refer to the figure shown to the left.
	FX5-32ER/ES FX5-32ET/ES FX5-32ET/ESS	140 (5.52")

Extension power supply module

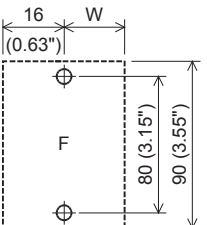
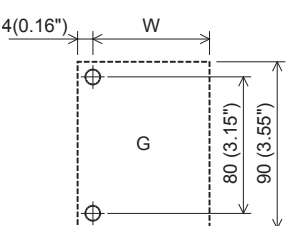
Dimensions	Model name	Mounting hole pitch W Unit: mm (inches)
	FX5-1PSU-5V	34 (1.34")
	FX3U-1PSU-5V	51 (2.01")

Bus conversion module

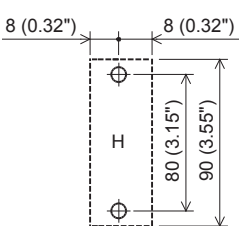
Dimensions	Model name	Mounting hole pitch W Unit: mm (inches)
	FX5-CNV-BUS	Refer to the figure shown to the left.

Intelligent function module

For the mounting hole dimensions of intelligent function modules, refer to  user's manuals of each product.

Hole pitches when extension module connected

Ex.

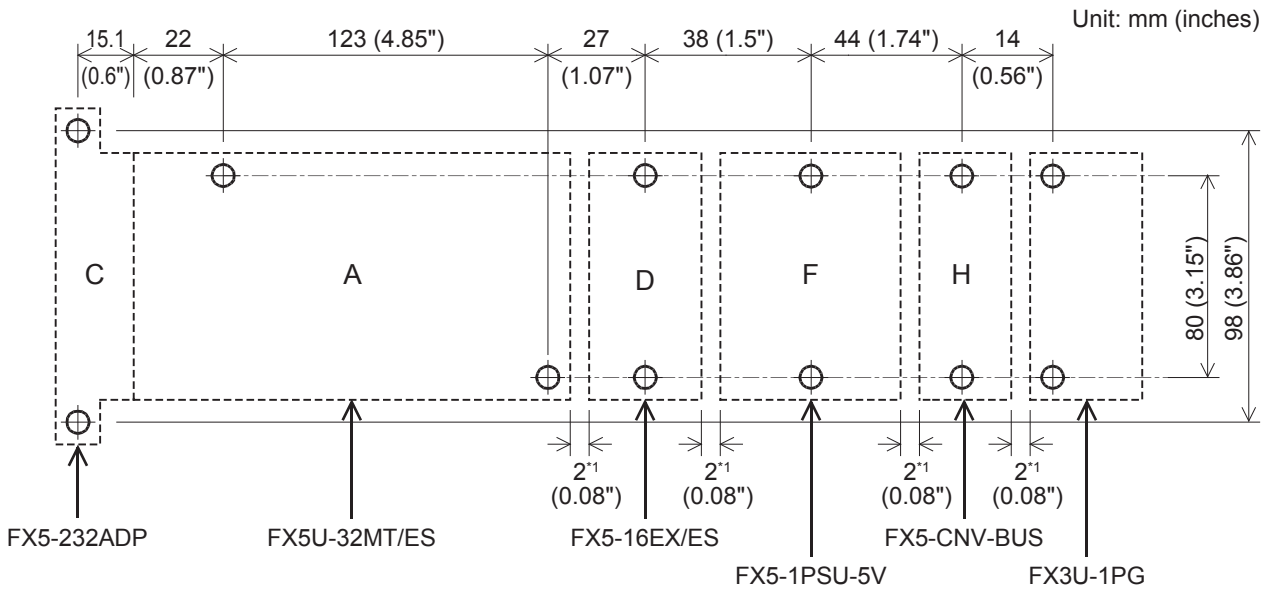

*1 The gap between products is 2 mm (0.08").

Installation of CPU module

Connect the expansion adapter to the CPU module before mounting the PLC in the enclosure.

For the connection method of the expansion adapter, refer to Page 73 Connection method B - connection of an expansion adapter.

The FX5U-32M□ is used as the CPU module in this example.

1. Make mounting holes on the mounting surface according to the external dimensions diagram.
2. Fit the CPU module (A in the right figure) to holes, and secure it with M4 screws (B in the right figure). (In the case of FX5U-64M□/80M□, there are four screw holes.)

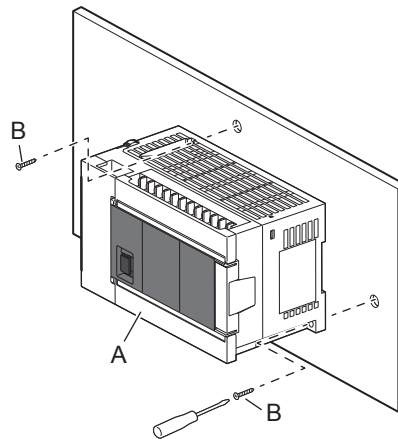

Installation of extension module

1. Make mounting holes on the mounting surface according to the external dimensions diagram.
2. Push in the DIN rail mounting hook (A in the right figure) of the extension module. If the DIN rail mounting hook is not pushed in, the screw hole is covered, and the extension module cannot be mounted. (This procedure may not be required, depending on the model.)
3. Fit the extension module (B in the right figure) to the holes, and secure it with M4 screws (C in the right figure).

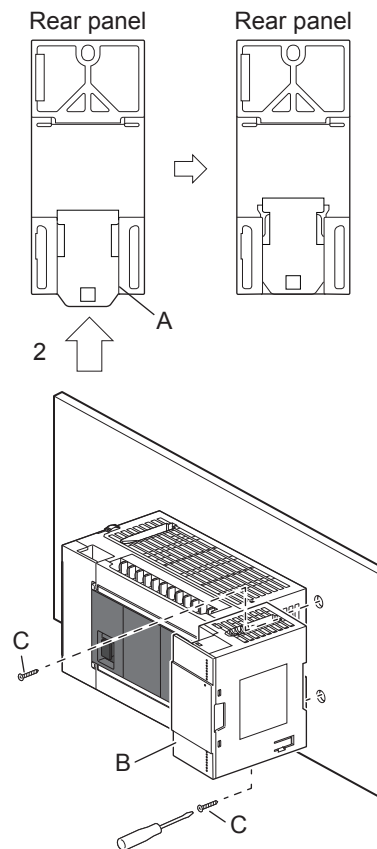

5.5 Connection Methods for CPU Module and Extension Devices

This section explains the connection methods for extension devices.

Connection of extension devices

The connection method varies depending on the combination of products, i.e., the CPU module, expansion board, expansion adapters, and extension modules.

The connection methods are explained with the following configuration example.

For connection method for extension power supply module (FX5-1PSU-5V), refer to [FX5-1PSU-5V HARDWARE MANUAL](#).

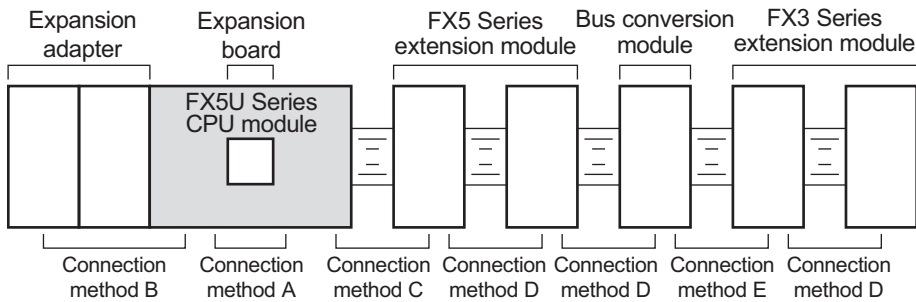

Connection method A - connection of an expansion board

This subsection explains how to connect the expansion board to the CPU module.

1. Remove the expansion board connector cover from the front face of the CPU module.

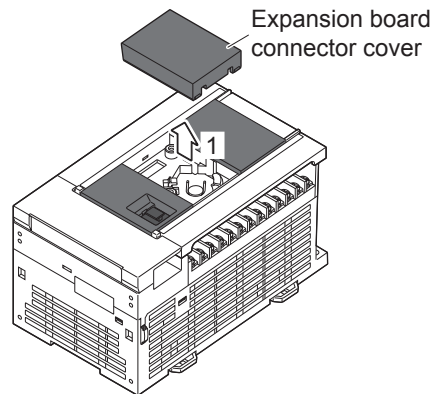

2. Connect the expansion board to the expansion board connector (C in the right figure).
 3. Fix the expansion board (E in the right figure) with provided M3 tapping screws (D in the right figure) to the CPU module.
- Tightening torque: 0.3 to 0.6N·m

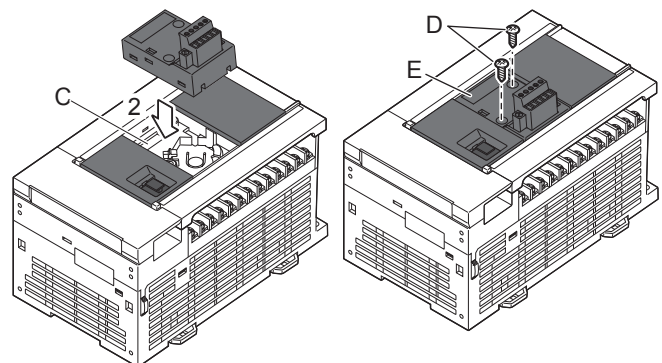

Connection method B - connection of an expansion adapter

This subsection explains how to connect the expansion adapter to the CPU module.

1. Slide the hook for coupling the expansion adapter of the CPU module (A in the right figure).

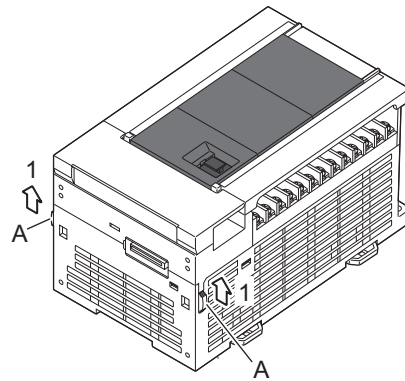

2. Connect the expansion adapter to the CPU module as shown in the right figure.
3. Slide the hook for coupling the expansion adapter of the CPU module (A in the right figure) to fix the expansion adapter (B in the right figure).

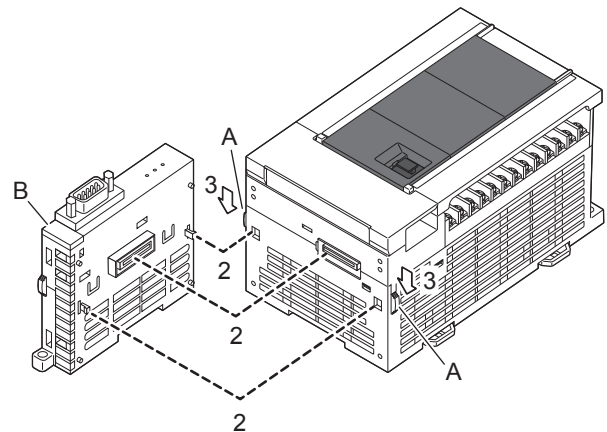

5

Connection method C - connection of an extension module to the CPU module

The procedure for connecting the extension module to the CPU module or powered input/output module is explained below.

1. Remove the extension connector cover (A in the right figure) on the right side of the surface of the CPU module or powered input/output module.
2. Connect the extension cable (B in the right figure) from the extension module to the extension connector of the CPU module or powered input/output module. Put the pullout tab (C in the right figure) of the extension cable inside the extension connector cover.
3. Fit the extension connector cover (A in the right figure).

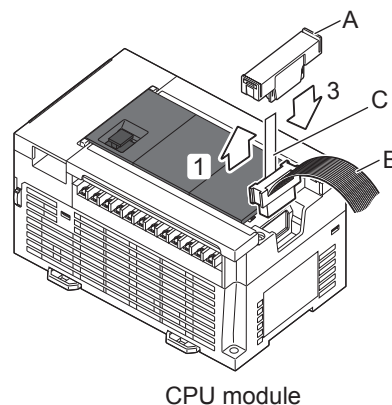

Connection method D - connection between extension modules

The procedure for connecting the extension modules is explained below. (Powered input/output module are excluded.)

1. Remove the top cover (B in the right figure) of the existing module (left side) (A in the right figure).
2. Connect the extension cable (C in the right figure) of the module to be connected (right side) to the existing module (left side) (A in the right figure).
3. Fit the top cover (B in the right figure).
4. Pull out the pullout tab (D in the right figure) of the extension cable on the right side of the cover.

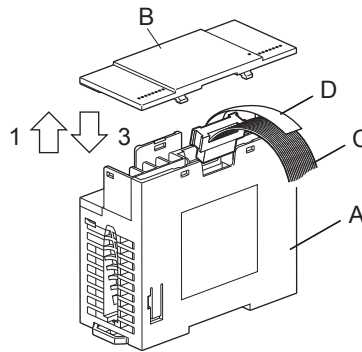

Connection method E - connection of an extension module to the bus conversion module

The procedure for connecting the extension module to the bus conversion module is explained below.

1. Connect the extension cable (A in the right figure) from the extension module to the extension connector of the bus conversion module.

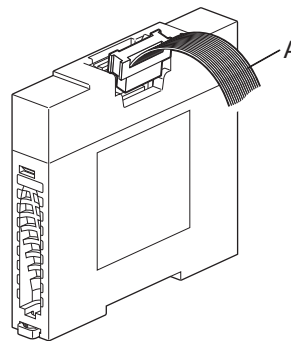

Point

Cautions on mounting and removing extension cables

- Make sure that the pullout tab of extension cables do not touch the conductive parts of the module.
- When removing the extension cable, pull the pullout tab of the extension cable straight up.

6 WIRING

6.1 Wiring Preparations

Wiring procedure

Before wiring, make sure that the source power supply is off.

1. Prepare the parts for wiring.

Prepare crimp terminals and cables needed for wiring. (☞ Page 77 Cable Connecting Procedure)

2. Wire the power supply terminals.

Connect the cables to the power [L] and [N] terminals.

Provide the protection circuit described in this chapter for the power supply circuit. (☞ Page 80 Power Supply Wiring)

3. Perform class D grounding for the ground [] terminal.

Connect the grounded wire to the terminal. (☞ Page 79 Grounding)

4. Wire the input [X] terminal.

When service power supply is used, select sink or source in the following wiring.

- For sink input, connect [24V]—[S/S] terminal
- For source input, connect [0V]—[S/S] terminal

Connect sensors and switches to the terminals. (☞ Page 84 Input Wiring)

5. Wire the output [Y] terminal.

Connect the load to terminals. (☞ Page 90 Output Wiring)

6. Wire built-in analog I/O terminal blocks.

Connect analog I/Os to terminals. (☞ Page 99 Analog Wiring)

7. Wire the built-in RS-485 communication terminal blocks and Ethernet communication connectors.

(☞ MELSEC iQ-F FX5 Series User's Manual [Ethernet Communication])

(☞ MELSEC iQ-F FX5 Series User's Manual [Serial Communication])

(☞ MELSEC iQ-F FX5 Series User's Manual [MODBUS Communication])

8. Wire intelligent function modules, expansion boards, and expansion adapters.

(☞ MELSEC iQ-F FX5 Series User's Manual [Serial Communication])

(☞ MELSEC iQ-F FX5 Series User's Manual [MODBUS Communication])

(☞ User's manual for each intelligent function module)

Removal and installation of removable terminal block

Removal

Loosen terminal block mounting screws on the left and right sides uniformly and remove the terminal block.

Installation

Place the terminal block at its predetermined position and tighten the terminal block mounting screws on the left and right sides uniformly.

Tightening torque: 0.4 to 0.5 N·m

Precautions

Do not tighten the terminal block mounting screws with torque exceeding the specified range.

Failure to do so may cause equipment failures or malfunctions.

Point

Make sure that there is no gap between the terminal block and mount position.

6.2 Cable Connecting Procedure

The cable connecting procedure is explained below.

Screw terminal block

Wire the screw terminal block in accordance with the following specifications.

For information concerning screw terminal blocks for intelligent function modules, refer to User's manual for each intelligent function module.

Terminal block screw size and tightening torque

Model	Terminal screw size	Tightening torque
CPU module	M3	0.5 to 0.8 N·m
I/O module		
Extension power supply module		
Intelligent function module	Refer to manuals for each product.	

Precautions

Do not tighten terminal screws with torque beyond the specified range. Otherwise it may cause equipment failure or malfunction.

Wire end treatment

Crimp terminal size differs depending on terminal screw size and wiring methods used.

- Use crimp terminals of the following sizes.

■ M3 terminal screw

- When a single wire is connected to a single terminal

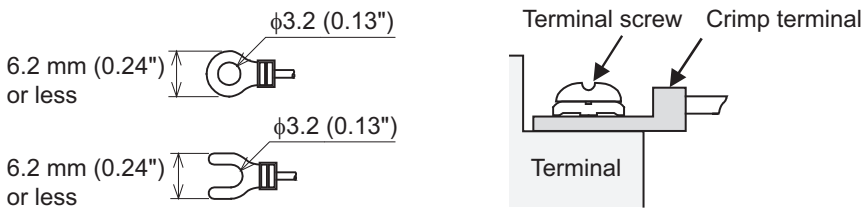

<Reference>

Manufacturer	Model	Supported standards	Crimp tool
JST Mfg. Co., Ltd.	FV1.25-B3A	UL Listed	YA-1 (JST Mfg. Co., Ltd.)
	FV2-MS3		

- When two wire are connected to a single terminal

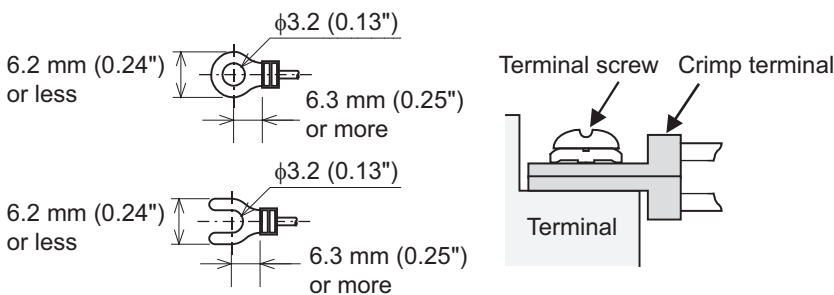

<Reference>

Manufacturer	Model	Supported standards	Crimp tool
JST Mfg. Co., Ltd.	FV1.25-B3A	UL Listed	YA-1 (JST Mfg. Co., Ltd.)

European-type terminal block

Wire the European-type terminal block in accordance with the following specifications.

Suitable wiring

	Number of wires connected per terminal	Wire size		Tightening torque
		Solid wire, Stranded wire	Wire ferrule with insulation sleeve	
Built-in analog I/O terminal block Terminal block for built-in RS-485 communication	One wire	0.2 to 0.5 mm ² (AWG24 to 20)	0.2 to 0.5 mm ² (AWG24 to 20)	0.22 to 0.25 N·m
	Two wires	0.2 mm ² (AWG24)	—	
Expansion board, expansion adapter	One wire	0.3 to 0.5 mm ² (AWG22 to 20)	0.3 to 0.5 mm ² (AWG22 to 20)	
	Two wires	0.3 mm ² (AWG22)	—	

Precautions

Do not tighten terminal screws with torque beyond the specified range. Otherwise it may cause equipment failure or malfunction.

Wire end treatment

Treat stranded and solid wires as they are or use wire ferrules with insulation sleeves for wiring terminals.

■When stranded and solid wires are treated as they are

- Twist the end of stranded wires and make sure that there are no loose wires.
- Do not solder-plate the electric wire ends.

Stripping dimensions of electric wire ends

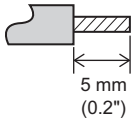
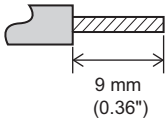
Built-in analog I/O terminal block, built-in RS-485 communication terminal block	Expansion board, expansion adapter
 <p>5 mm (0.2")</p>	 <p>9 mm (0.36")</p>

■When wire ferrules with insulation sleeves are used

Depending on the thickness of a wiring sheath used, it may be difficult to insert the sheath into an insulation sleeve. Refer to the external dimensions as a reference to select wires.

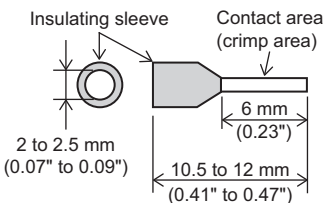
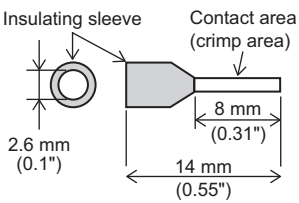
Built-in analog I/O terminal block, built-in RS-485 communication terminal block	Expansion board, expansion adapter
 <p>Insulating sleeve 2 to 2.5 mm (0.07" to 0.09")</p> <p>Contact area (crimp area) 6 mm (0.23")</p> <p>10.5 to 12 mm (0.41" to 0.47")</p>	 <p>Insulating sleeve 2.6 mm (0.1")</p> <p>Contact area (crimp area) 8 mm (0.31")</p> <p>14 mm (0.55")</p>

<Reference>

	Manufacturer	Model	Crimp tool
Built-in analog I/O terminal block Terminal block for built-in RS-485 communication	Phoenix Contact GmbH & Co. KG	AI 0.5-6 WH	CRIMPFOX 6 CRIMPFOX 6T-F
Expansion board, expansion adapter		AI 0.5-8 WH	

■ Tool

For tightening terminals, use a small, commercially-available screwdriver with a straight tip. The recommended shape is shown in the figure on the right.

■ Precautions

When a precision screwdriver with a small grip is used, the specified tightening torque cannot be obtained. Use the following screwdriver or equivalent product (grip diameter: 25 mm (0.99")) to obtain the tightening torque specified above.

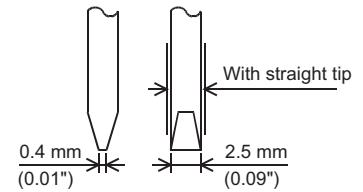

<Reference>

Manufacturer	Model
Phoenix Contact GmbH & Co. KG	SZS 0.4×2.5

6.3 Grounding

Perform the following.

- Perform class D grounding (Grounding resistance: 100 Ω or less).
- Ground the PLC independently when possible.
- If the PLC cannot be grounded independently, perform the "Common grounding" shown below.

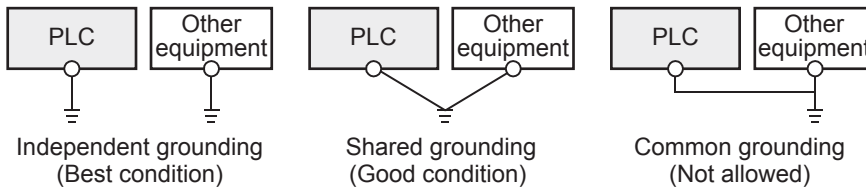

PLC extension devices (excluding expansion boards and communication adapters)

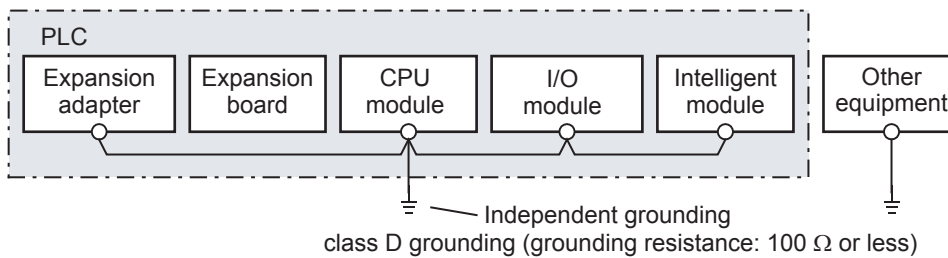

- Use a grounding wire with thickness of AWG 14 (2 mm²) or thicker.
- Locate the ground point as close to the PLC as possible to minimize the length of the grounding wire.

6.4 Power Supply Wiring

Examples of AC power supply wiring

Power supply example for sink input [-common]

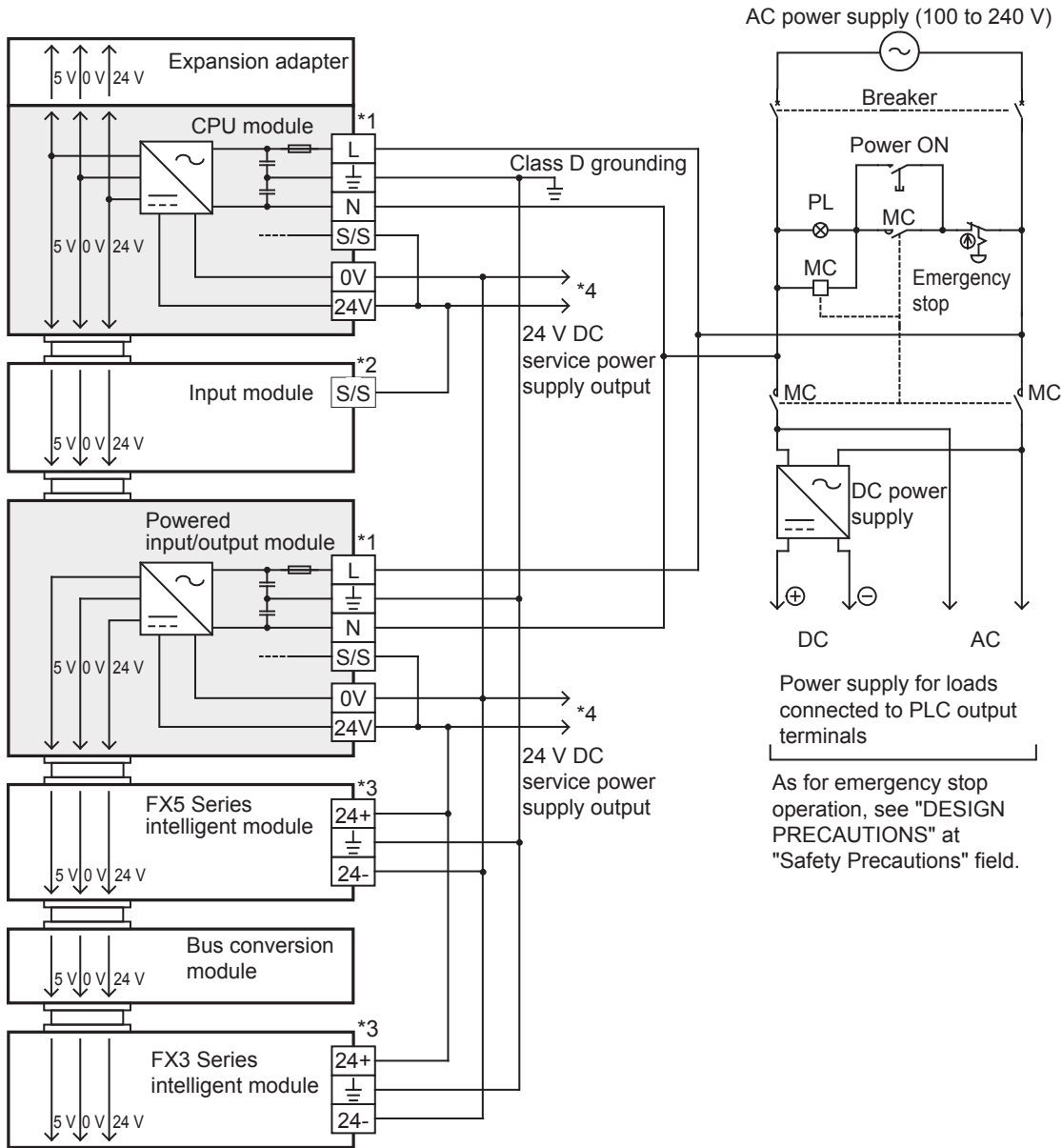

- *1 Connect the AC power supply to the [L] and [N] terminals (common for 100 V AC system and 200 V AC system).
Make sure that the powered input/output module is turned on at the same time as the CPU module or earlier than the CPU module.
- *2 Connect the [24V] terminal of the CPU module to the [S/S] terminal of the input module.
- *3 Some intelligent function modules may not have power supply terminals.
When using an external power supply, turn on the power supply at the same time as the CPU module or earlier than the CPU module.
When turning off the power, confirm the safety of the system and turn off the power of the PLC (including extension devices) at the same time.
- *4 Do not connect the [24V] terminals (24 V DC service power supply) of the CPU module and the powered input/output module with each other. Connect the [0V] terminal.

Power supply for loads connected to PLC output terminals

As for emergency stop operation, see "DESIGN PRECAUTIONS" at "Safety Precautions" field.

Power supply example for source input [+common]

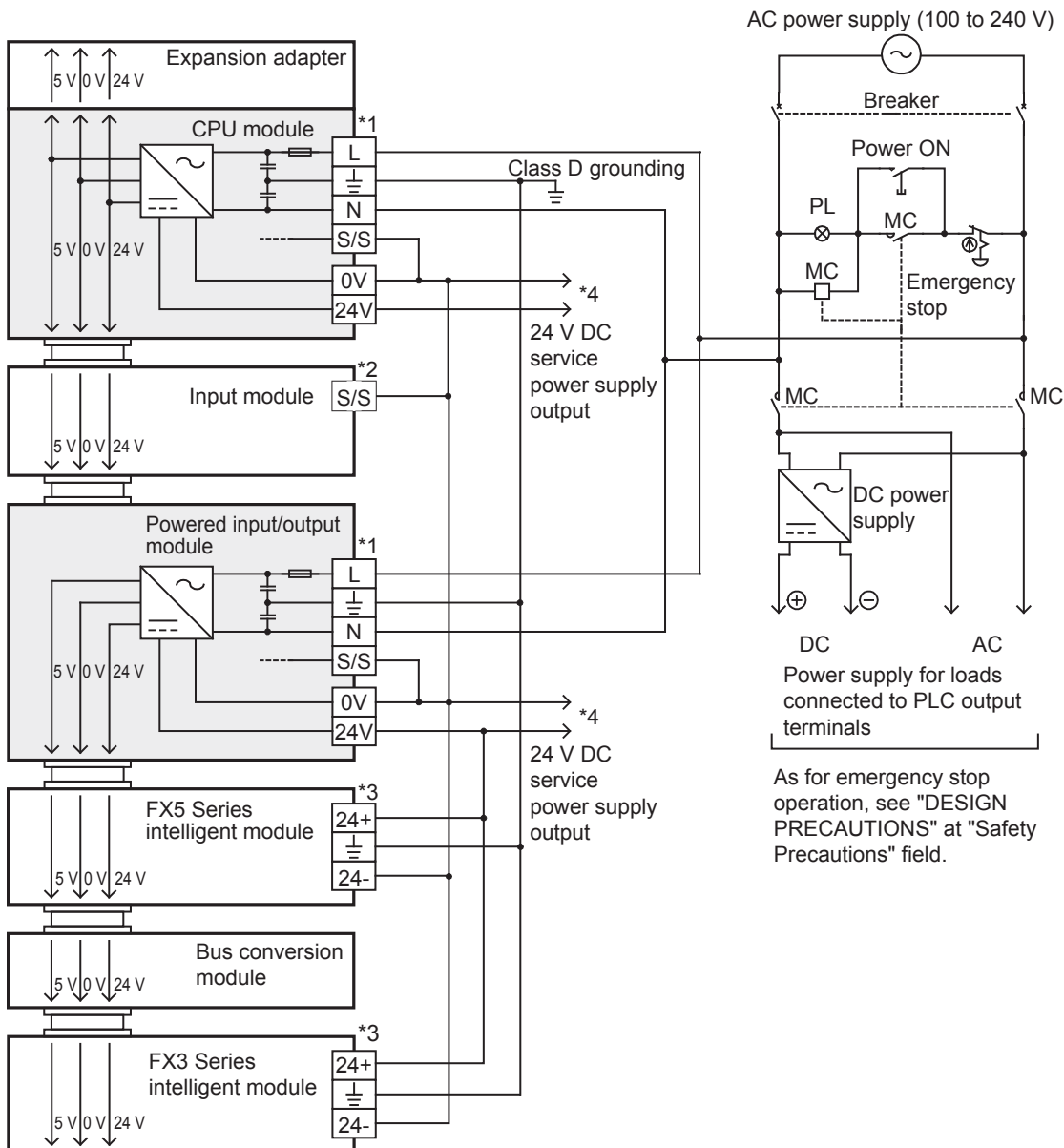

- *1 Connect the AC power supply to the [L] and [N] terminals (common for 100 V AC system and 200 V AC system).
Make sure that the powered input/output module is turned on at the same time as the CPU module or earlier than the CPU module.
- *2 Connect the [0V] terminal of the CPU module to the [S/S] terminal of the input module.
- *3 Some intelligent function modules may not have power supply terminals.
When using an external power supply, turn on the power supply at the same time as the CPU module or earlier than the CPU module.
When turning off the power, confirm the safety of the system and turn off the power of the PLC (including extension devices) at the same time.
- *4 Do not connect the [24V] terminals (24 V DC service power supply) of the CPU module and the powered input/output module with each other. Connect the [0V] terminal.

Wiring example for an extension power supply module (sink input [-common])

The following example shows wiring for an extension power supply module when sink input [-common] is used.

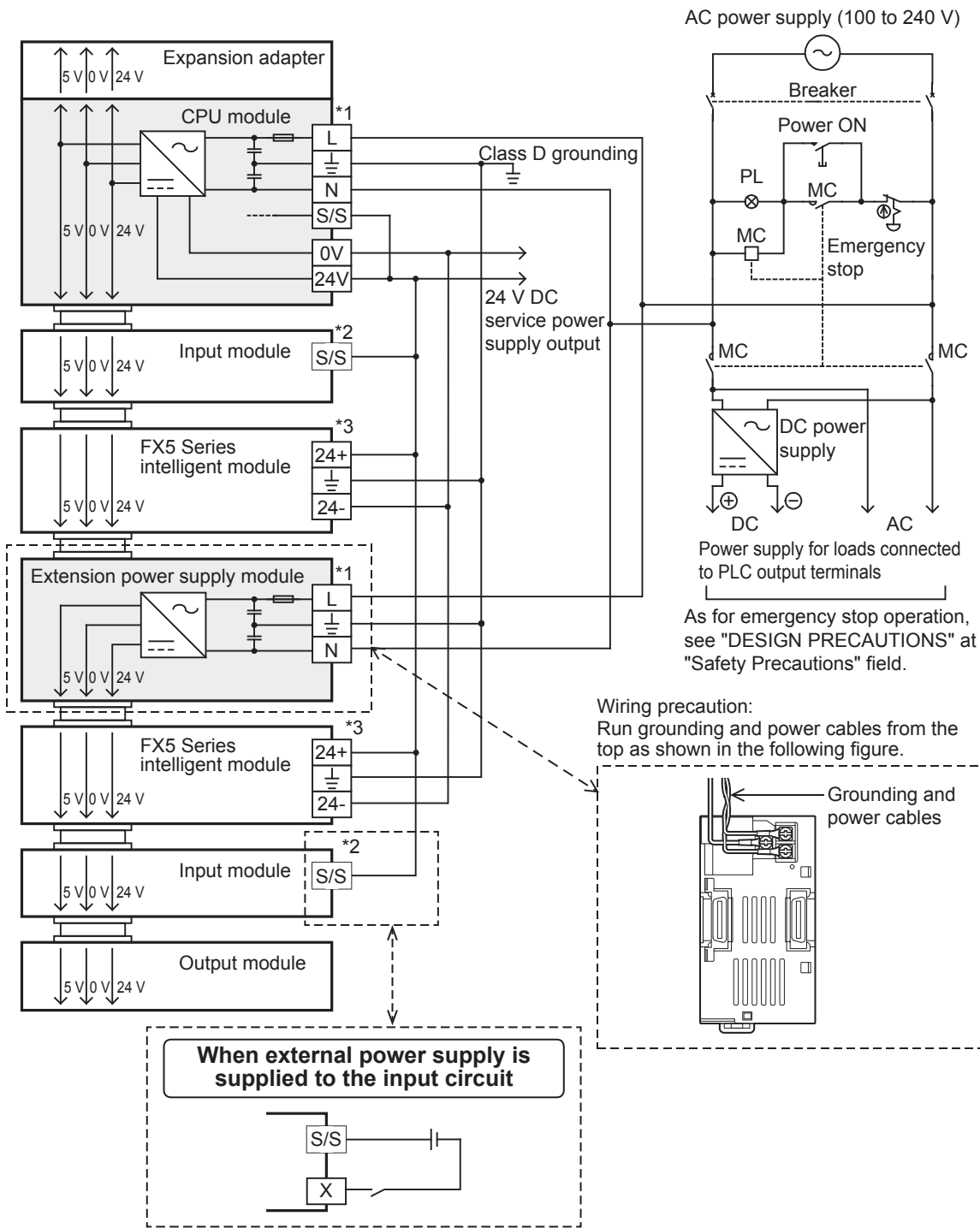

- *1 Connect the AC power supply to the [L] and [N] terminals (common for 100 V AC system and 200 V AC system). Make sure that the power of the extension power supply module is turned on at the same time as the CPU module or earlier than the CPU module.
- *2 Connect the [24V] terminal of the CPU module to the [S/S] terminal of the input module.
- *3 Some intelligent function modules may not have power supply terminals.
When using an external power supply, turn on the power supply at the same time as the CPU module or earlier than the CPU module.
When turning off the power, confirm the safety of the system and turn off the power of the PLC (including extension devices) at the same time.

Wiring example for an extension power supply module (source input [+common])

The following example shows wiring for an extension power supply module when source input [+common] is used.

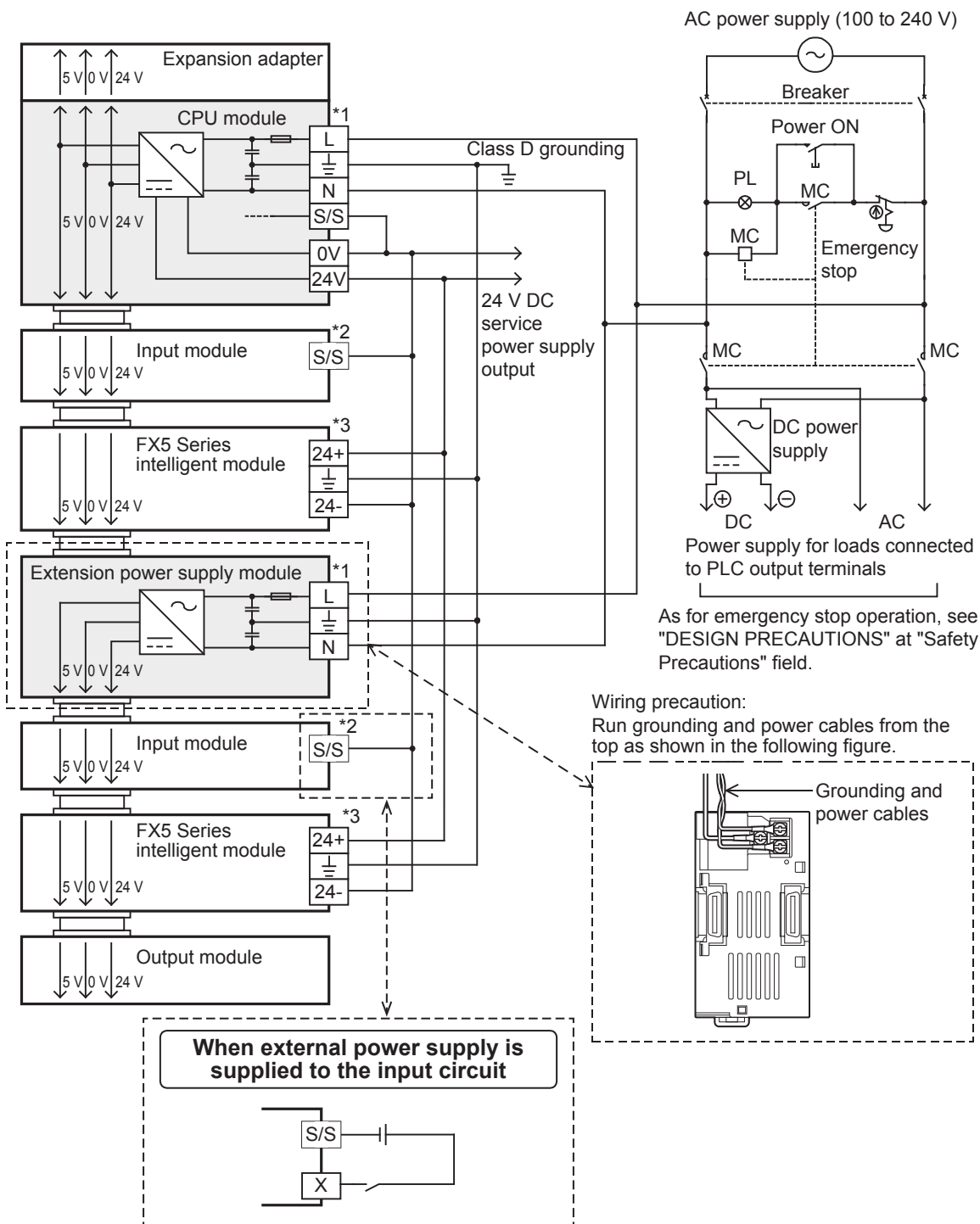

- *1 Connect the AC power supply to the [L] and [N] terminals (common for 100 V AC system and 200 V AC system). Make sure that the power of the extension power supply module is turned on at the same time as the CPU module or earlier than the CPU module.
- *2 Connect the [0V] terminal of the CPU module to the [S/S] terminal of the input module.
- *3 Some intelligent function modules may not have power supply terminals.
When using an external power supply, turn on the power supply at the same time as the CPU module or earlier than the CPU module. When turning off the power, confirm the safety of the system and turn off the power of the PLC (including extension devices) at the same time.

6.5 Input Wiring

The input wiring of the CPU module and I/O modules is explained below.

24 V DC input (Sink and source input type)

For input specifications of the CPU module, refer to [Page 21 Input Specifications](#).

For input specifications of the I/O modules, refer to [Page 127 Input specifications](#).

Sink and source input

■ Differences between the sink input circuit and the source input circuit

- Sink input [-common]
Sink input means a DC input signal with current-flow from the input (X) terminal.
When a device such as a transistor output type sensor is connected, NPN open collector transistor output can be used.
- Source input [+common]
Source input means a DC input signal with current-flow into the input (X) terminal.
When a device such as a transistor output type sensor is connected, PNP open collector transistor output can be used.

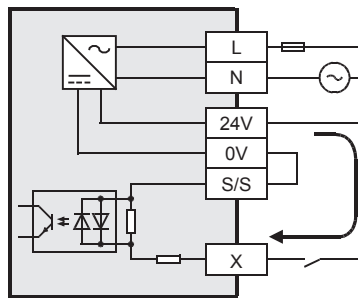
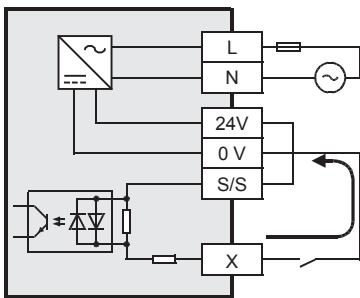

■ Switching between sink/source inputs

To switch the input type to sink or source input, wire the [S/S] terminal to the [0V] or [24V] terminal.

- Sink input: Connect the [24V] terminal and [S/S] terminal. ([Page 88 Sink input \[AC power supply type\]](#))
- Source input: Connect the [0V] terminal and [S/S] terminal. ([Page 89 Source input \[AC power supply type\]](#))

Point

All inputs (X) of the CPU module can be set to either sink input or source input by selection.

Handling of 24 V DC input

Input terminal

- Sink input

When a no-voltage contact or NPN open collector transistor output is connected between an input (X) terminal and the [0V] terminal and the circuit is closed, the input (X) turns on. The input display LED turns on.

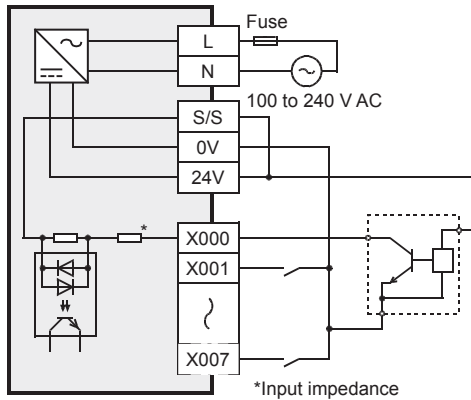

- Source input

When a no-voltage contact or PNP open collector transistor output is connected between an input (X) terminal and the [24V] terminal and the circuit is closed, the input (X) turns on. The input display LED turns on.

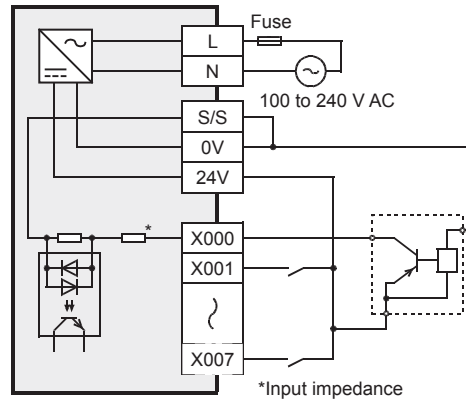

- RUN terminal setting

X000 to X017 of the CPU module can be used as RUN input terminals by setting parameters.

☞ MELSEC iQ-F FX5 Series User's Manual [Application]

Input circuit

- Function of input circuit

The primary and secondary circuits for input are insulated with a photocoupler, and the second circuit is provided with a C-R filter.

The C-R filter is designed to prevent malfunctions caused by chattering of the input contact and noise from the input line.

Input has a response delay switching from ON to OFF and OFF to ON, shown in the following table.

Item			Specifications
Input response time (H/W filter delay)	FX5U-32M□	X000 to X005	ON: 2.5 μs or less OFF: 2.5 μs or less
	FX5U-64M□, FX5U-80M□	X000 to X007	ON: 2.5 μs or less OFF: 2.5 μs or less
	FX5U-32M□	X006 to X017	ON: 30 μs or less OFF: 50 μs or less
	FX5U-64M□, FX5U-80M□	X010 to X017	ON: 30 μs or less OFF: 50 μs or less
	FX5U-64M□, FX5U-80M□	X020 and subsequent	ON: 50 μs or less OFF: 150 μs or less
	I/O module		

- Change of filter time

All input circuits have digital filters, and the input response time shown in the following table can be added by setting parameters.

When using this product in an environment with much noise, set the digital filter.

Item	Specifications
Input response time (Digital filter setting value)	None, 10 μs, 50 μs, 0.1 ms, 0.2 ms, 0.4 ms, 0.6 ms, 1 ms, 5 ms, 10 ms (initial values), 20 ms, 70 ms

Input sensitivity

For input signal current and Input sensitivity current of the CPU module, refer to ☞ Page 21 Input Specifications.

For input signal current and Input sensitivity current of the I/O modules, refer to ☞ Page 127 Input specifications.

Precautions for connecting input devices

■In the case of no-voltage contact

Use input devices appropriate for low electric current.

If no-voltage contacts for high current (switches) are used, contact failure may occur.

■In the case of input device with built-in series diode

The voltage drop of the series diode should be the following value or less.

Also make sure that the input current is over the input-sensing level while the switches are on.

Item		Specifications	
Voltage drop	FX5U-32M□	X000 to X005	3.9 V
	FX5U-64M□, FX5U-80M□	X000 to X007	
	FX5U-32M□	X006 to X017	4.1 V
	FX5U-64M□, FX5U-80M□	X010 to X017	
	FX5U-64M□, FX5U-80M□	X020 and subsequent	2.4 V
	I/O module		

■In the case of input device with built-in parallel resistance

Use a device having a parallel resistance R_p (k Ω) of the following value or more.

Item		Specifications	
Parallel resistance R_p (k Ω)	FX5U-32M□	X000 to X005	14
	FX5U-64M□, FX5U-80M□	X000 to X007	
	FX5U-32M□	X006 to X017	15
	FX5U-64M□, FX5U-80M□	X010 to X017	
	FX5U-64M□, FX5U-80M□	X020 and subsequent	13
	I/O module		

If the resistance is less than the above parallel resistance R_p (k Ω), connect a bleeder resistance R_b (k Ω) obtained by the following formula as shown in the following figure.

Item		Specifications	
Bleeder resistance R_b (k Ω)	FX5U-32M□	X000 to X005	5 R_p / (14- R_p) or less
	FX5U-64M□, FX5U-80M□	X000 to X007	
	FX5U-32M□	X006 to X017	4 R_p / (15- R_p) or less
	FX5U-64M□, FX5U-80M□	X010 to X017	
	FX5U-64M□, FX5U-80M□	X020 and subsequent	6 R_p / (13- R_p) or less
	I/O module		

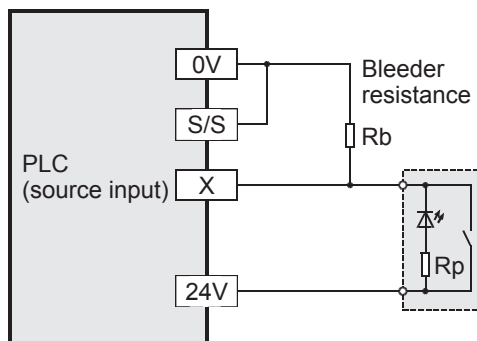
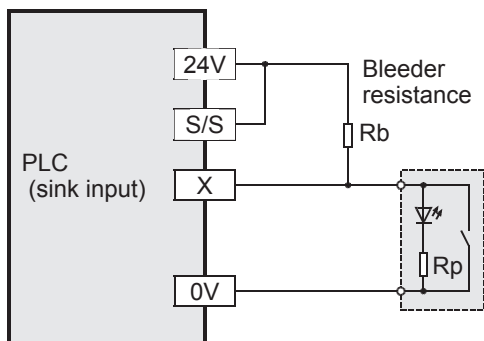

■ In the case of 2-wire proximity switch

Use a two-wire proximity switch whose leakage current, I_l is 1.5 mA or less when the switch is off.

If the resistance is larger than leakage current, I_l of 1.5 mA, connect a bleeder resistance R_b (k Ω), obtained by the following formula as shown in the following figure.

Item			Specifications
Bleeder resistance R_b (k Ω)	FX5U-32M□	X000 to X005	7 / (1 I_l -1.5) or less
	FX5U-64M□, FX5U-80M□	X000 to X007	
	FX5U-32M□	X006 to X017	7 / (1 I_l -1.5) or less
	FX5U-64M□, FX5U-80M□	X010 to X017	
	FX5U-64M□, FX5U-80M□	X020 and subsequent	9 / (1 I_l -1.5) or less
	I/O module		

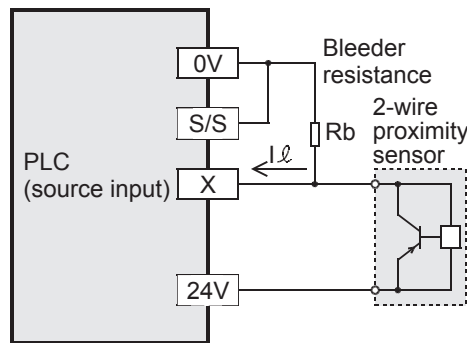
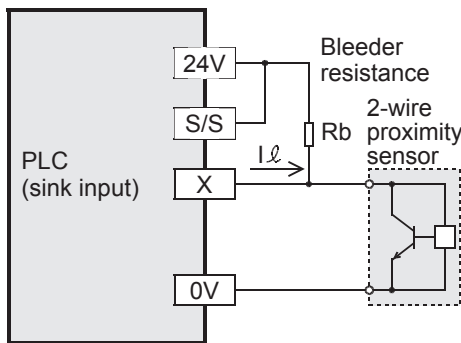

■When the input signal cannot be received because the current is insufficient

The current rating for the CPU module in X020 or more and the I/O module is 4 mA.

In some cases, depending on extension devices used, it may not be possible to receive the input signal, due to the insufficient current. Take the following action in such case.

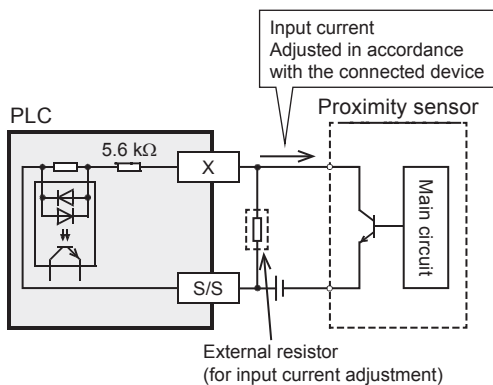

In the case of capturing high-speed pulses

When capturing pulses of a response frequency of 50 to 200 kHz on using the input X000 to X007 (FX5U-32M□ is X000 to X005.), wire the terminals as stated below.

- The wiring length should be 5 m (16'4") or less.
- Use shielded twisted-pair cables for connecting cables. Ground the shield of each shielded cable only on the CPU module side.
- Connect a 1.5 k Ω (1 W or more) bleeder resistance to the input terminal, so that the sum of the load current of the open collector transistor output on the mating device and the input current of the CPU module is 20 mA or more.

The above-mentioned restrictions are due to specifications of connecting device (encoder etc.).

Please adjust the cable length and load, for connecting device.

Input wiring example

Sink input [AC power supply type]

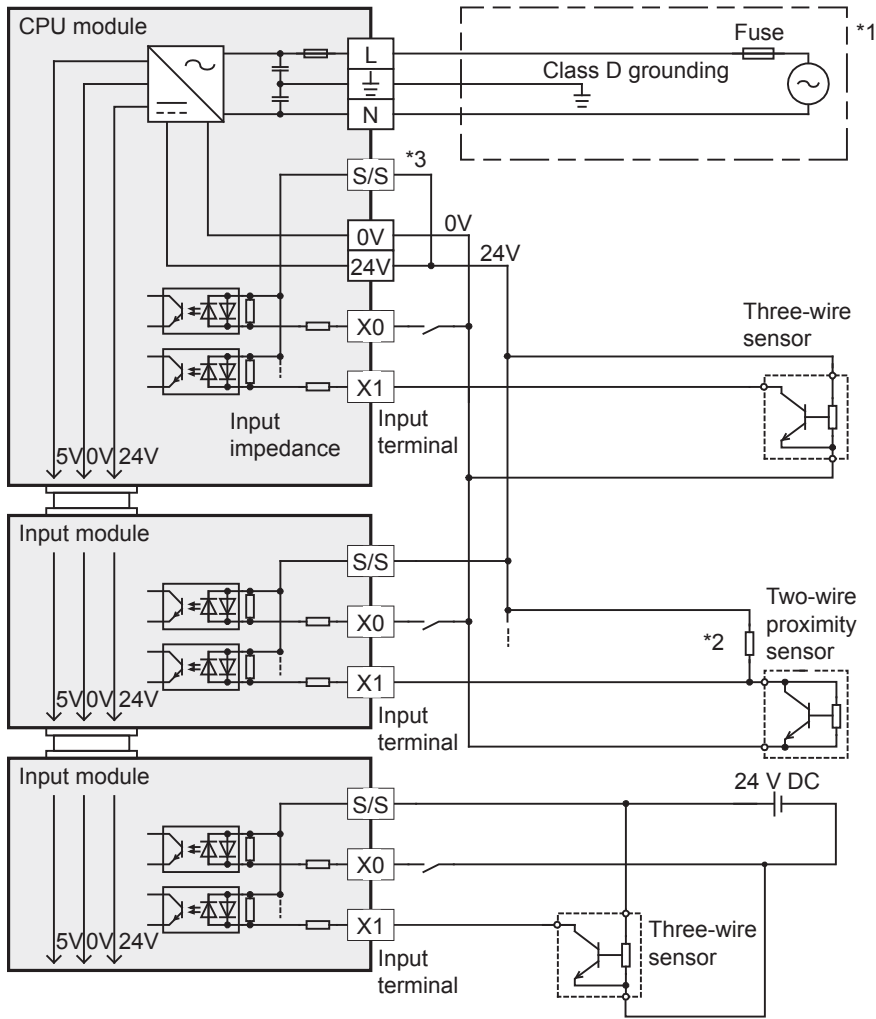

*1 Handle the power supply circuit properly in accordance with "Power Supply Wiring."

*2 For an input device having a parallel resistance or a two-wire proximity switch, a bleeder resistance may be required.

*3 In the case of sink input wiring, short-circuit the [S/S] and [24V] terminals of the CPU module.

Point

The service power supply or external power supply can be used for all inputs (X) of the CPU module. However you need to select either one for each CPU module or I/O module. Both power supplies cannot be used together in the same module.

Source input [AC power supply type]

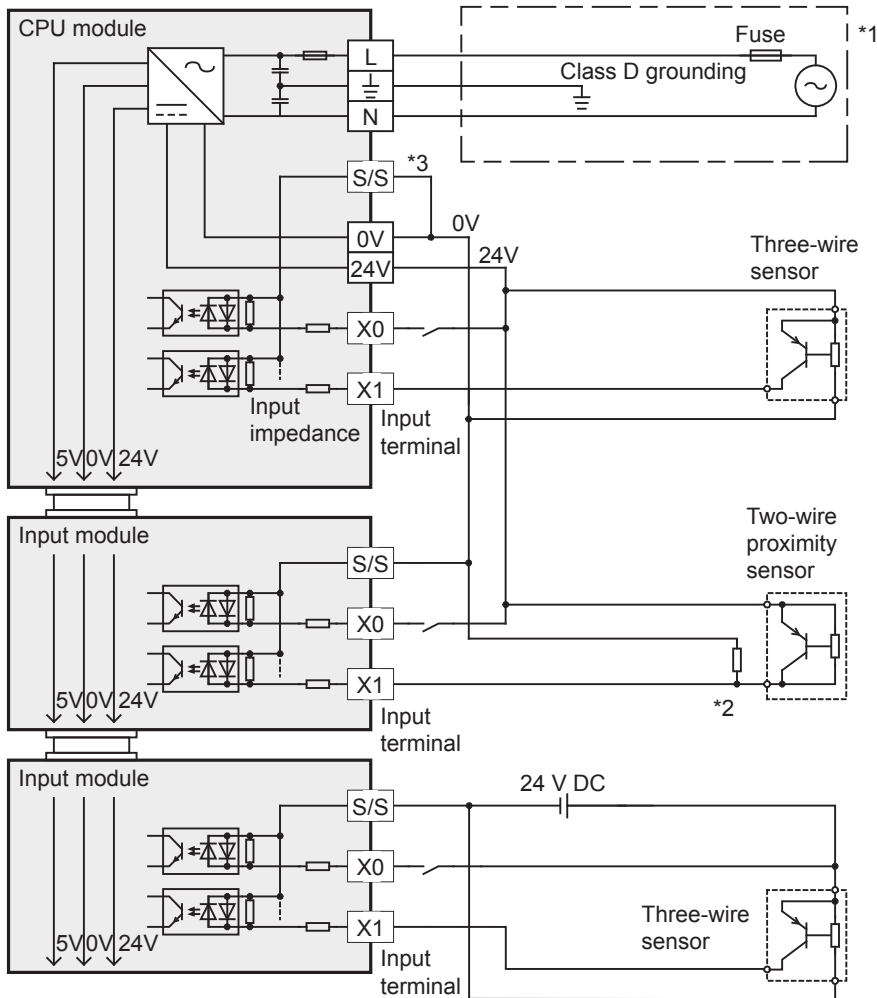

*1 Handle the power supply circuit properly in accordance with "Power Supply Wiring."

*2 For an input device having a parallel resistance or a two-wire proximity switch, a bleeder resistance may be required.

*3 In the case of source input wiring, short-circuit the [S/S] and [0V] terminals of the CPU module.

Point

The service power supply or external power supply can be used for all inputs (X) of the CPU module. However you need to select either one for each CPU module or I/O module. Both power supplies cannot be used together in the same module.

6.6 Output Wiring

The relay output wiring of the CPU module and I/O modules is explained below.

Relay output

For output specifications of the CPU module, refer to [Page 23 Output Specifications](#).

For output specifications of the I/O modules, refer to [Page 128 Output specifications](#).

Product life of relay output contacts

The product life of relay output contacts varies considerably depending on the load type used.

Note that loads generating reverse electromotive force or rush current may cause poor contact or welding of contacts which may lead to considerable reduction of the contact product life.

■Inductive load

Inductive loads generate large reverse electromotive force between contacts at shutdown, which may cause arc discharge. At a fixed current consumption, as the power factor (phase between current and voltage) gets smaller, the arc energy gets larger. The standard life of contacts used for inductive AC loads, such as general contactors and solenoid valves, is 500,000 operations at 20 VA.

The following table shows the approximate life of a relay based on the results of an operation life test.

- Test condition: 1 sec. ON/1 sec. OFF

Load capacity		Contact life
20 VA	0.2 A/100 V AC	3,000,000 times
	0.1 A/200 V AC	
35 VA	0.35 A/100 V AC	1,000,000 times
	0.17 A/200 V AC	
80 VA	0.8 A/100 V AC	200,000 times
	0.4 A/200 V AC	

The product life of relay contacts becomes considerably shorter than the above conditions when the rush overcurrent is shut down.

Please refer to the following measures regarding the inductive load.

[Page 92 Contact protection circuit for inductive loads](#)

Some types of inductive loads generate rush current 5 to 15 times the stationary current at activation. Make sure that the rush current does not exceed the current corresponding to the maximum specified resistance load.

■Lamp load

Lamp loads generally generate rush current 10 to 15 times the stationary current. Make sure that the rush current does not exceed the current corresponding to the maximum specified resistance load.

■Capacitive load

Capacitive loads can generate rush current 20 to 40 times the stationary current. Make sure that the rush current does not exceed the current corresponding to the maximum specified resistance load.

Capacitive loads such as capacitors may be present in electronic circuit loads including inverters.

■Resistance load

For maximum load specifications of resistance load, refer to the following.

For output specifications of the CPU module, refer to [Page 23 Output Specifications](#).

For output specifications of the I/O modules, refer to [Page 128 Output specifications](#).

Handling of relay output

■Output terminal

One common terminal is used for 4 or 8 relay output points.

The common terminal blocks can drive loads of different circuit voltage systems (for example, 100 V AC and 24 V DC).

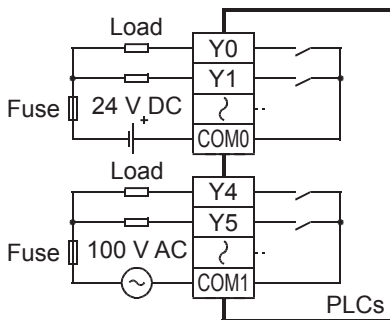

■External power supply

Use an external power supply of 30 V DC or less or 240 V AC or less (250 V AC or less when the module does not comply with CE, UL, cUL standards) for loads.

■Insulation of circuit

The PLC internal circuit and external load circuits are electrically insulated between the output relay coil and contact.

The common terminal blocks are separated from one another.

■Display of operation

When power is applied to the output relay coil, the LED is lit, and the output contact is turned on.

■Response time

The response time of the output relay from when the power is applied to the coil until the output contact is turned on and from when the coil is shut off until the output contact is turned off is approx. 10 ms.

■Output current

At a circuit voltage of 240 V AC or less (250 V AC or less when the module does not comply with CE, UL, cUL standards), a resistance load of 2 A per point or an inductive load of 80 VA or less (100 V AC or 200 V AC) can be driven.

For the life of the contact for switching an inductive load, refer to [Page 90](#) Product life of relay output contacts.

When an inductive load is switched, connect a diode (for commutation) or a surge absorber in parallel with this load.

DC circuit	AC circuit
Diode (for commutation)	Surge absorber

■Open circuit leakage current

There is no leakage current when the outputs are OFF.

Wiring precautions

■Protection circuit for load short-circuiting

A short-circuit at a load connected to an output terminal could cause burnout at the output element or the PCB. To prevent this, a protection fuse should be inserted at the output.

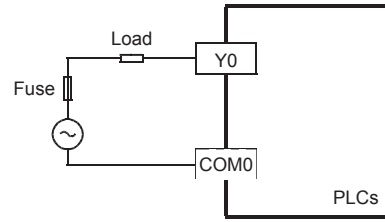

■Contact protection circuit for inductive loads

An internal protection circuit for the relays is not provided for the relay output circuit in this product. It is recommended to use inductive loads with built-in protection circuits.

When using loads without built-in protection circuits, insert an external contact protection circuit, etc. to reduce noise and extend product life.

- DC circuit

Connect a diode in parallel with the load.

The diode (for commutation) must comply with the following specifications.

- Reverse voltage: 5 to 10 times the load voltage
- Forward current: Load current or more

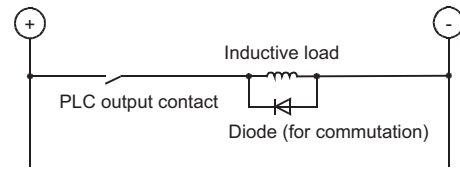

- AC circuit

Connect a surge absorber (CR composite parts like surge killer, spark killer, etc.) parallel to the load. Select a surge absorber with voltage rating that is suitable for the output used.

- Electrostatic capacity: Approx. 0.1 μF
- Resistance: Approx. 100 to 200 Ω

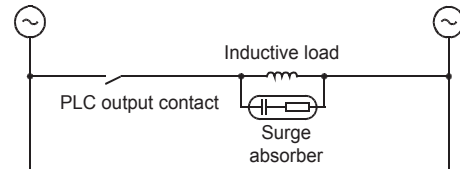

■Interlock

For loads such as forward/reverse contactors, etc., where a hazardous condition could result if switched ON simultaneously, an external interlock should be provided for interlocking along with an interlock in the PLC program, as shown to the right.

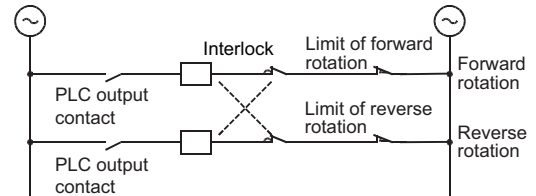

■In-phase

PLC output contacts (*) should be used in an "in-phase" manner.

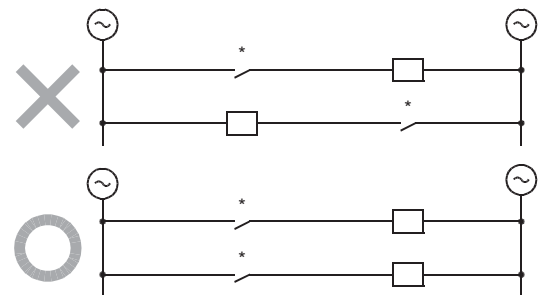

Transistor output

For output specifications of the CPU module, refer to Page 23 Output Specifications.

For output specifications of the I/O modules, refer to Page 128 Output specifications.

Sink and source output

Sink output and source output products are available for transistor outputs of the CPU module and I/O modules.

Differences in circuit

- Sink output [-common]

Output to make load current flow into the output (Y) terminal is called sink output.

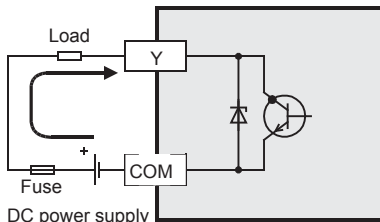

DC power supply
A number is entered in the □ of [COM□].

- Source output [+common]

Output to make load current flow out of the output (Y) terminal is called source output.

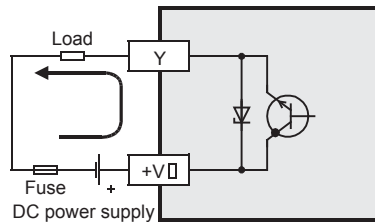

DC power supply
A number is entered in the □ of [+V□].

Handling of transistor output

Output terminal

4 or 8 transistor output points are covered by one common terminal.

- Sink output

Connect each COM□ (number) terminal to the minus side of the load power supply.

The COM□ terminals are not connected internally.

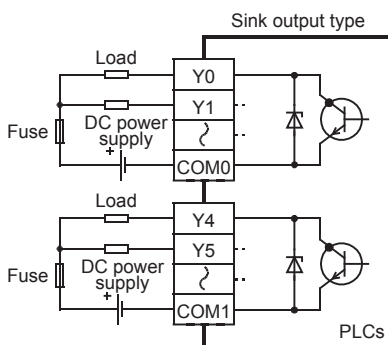

- Source output

Connect +V□ (number) terminal to the plus side of the load power supply.

The +V□ terminals are not connected internally.

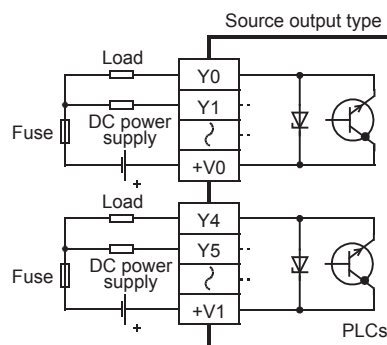

External power supply

For driving the load, use a smoothing power supply of 5 to 30 V DC that can output current two or more times the current rating of the fuse connected to the load circuit.

Insulation of circuit

The internal circuit of the PLC and the output transistor are insulated with a photocoupler.

The common blocks are separated from one another.

Display of operation

Operation indicator LEDs are built into the CPU module and output modules, and turn ON when photocouplers are activated, and the transistors are switched on.

■Response time

Time taken from when the photocoupler of the module is driven (or shut off) to when the transistor is turned on (or off) differs depending on the output terminal used. For specifications of each module, refer to the following.

For output specifications of the CPU module, refer to Page 23 Output Specifications.

For output specifications of the I/O modules, refer to Page 128 Output specifications.

Point

The transistor OFF time is longer under lighter loads. For example, under a load of 24 V DC 40 mA, the response time is approx. 0.3 ms.

When response performance is required under light loads, provide a dummy resistor as shown below to increase the load current.

• Sink output type

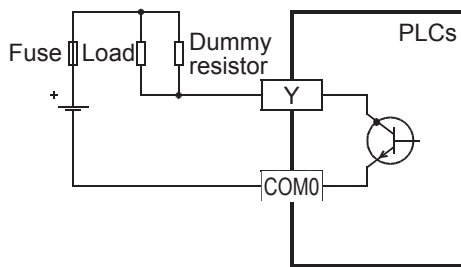

• Source output type

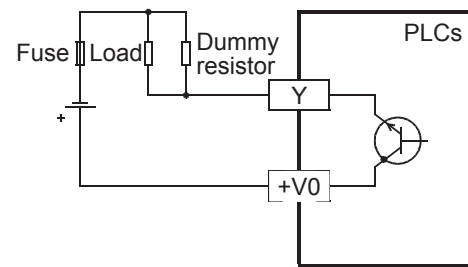

■Output current

Maximum load differs for each module. For specifications of each module, refer to the following.

For output specifications of the CPU module, refer to Page 23 Output Specifications.

For output specifications of the I/O modules, refer to Page 128 Output specifications.

When driving a semiconductor device, carefully check the input voltage characteristics of the device.

■Open circuit leakage current

0.1 mA or less

Wiring precautions

■Protection circuit for load short-circuiting

A short-circuit at a load connected to an output terminal could cause burnout at the output device or the PCB.

To prevent this, a protection fuse should be inserted at the output. Use a load power supply capacity that is at least 2 times larger than the load current.

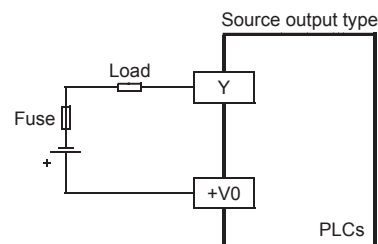
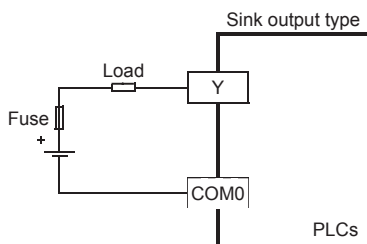

■ Contact protection circuit for inductive loads

When an inductive load is connected, connect a diode (for commutation) in parallel with the load as necessary.

The diode (for commutation) must comply with the following specifications.

- Standard
- Reverse voltage: 5 to 10 times the load voltage
- Forward current: Load current or more

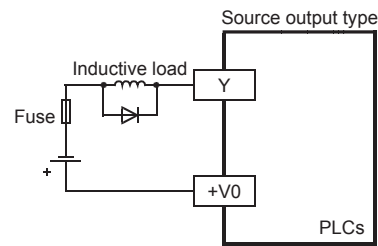
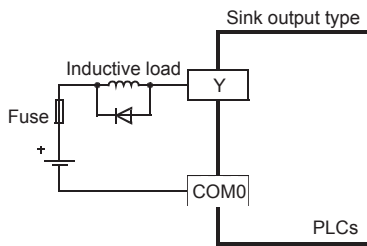

■ Interlock

For loads such as forward/reverse contactors, etc., where a hazardous condition could result if switched ON simultaneously, an external interlock should be provided for interlocking along with an interlock in the PLC program, as shown below.

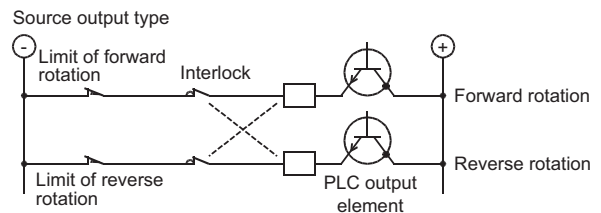
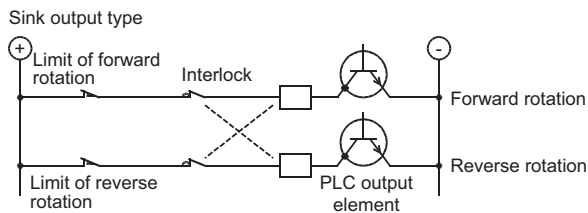

Output wiring example

Relay output

AC power supply (100 to 240 V)

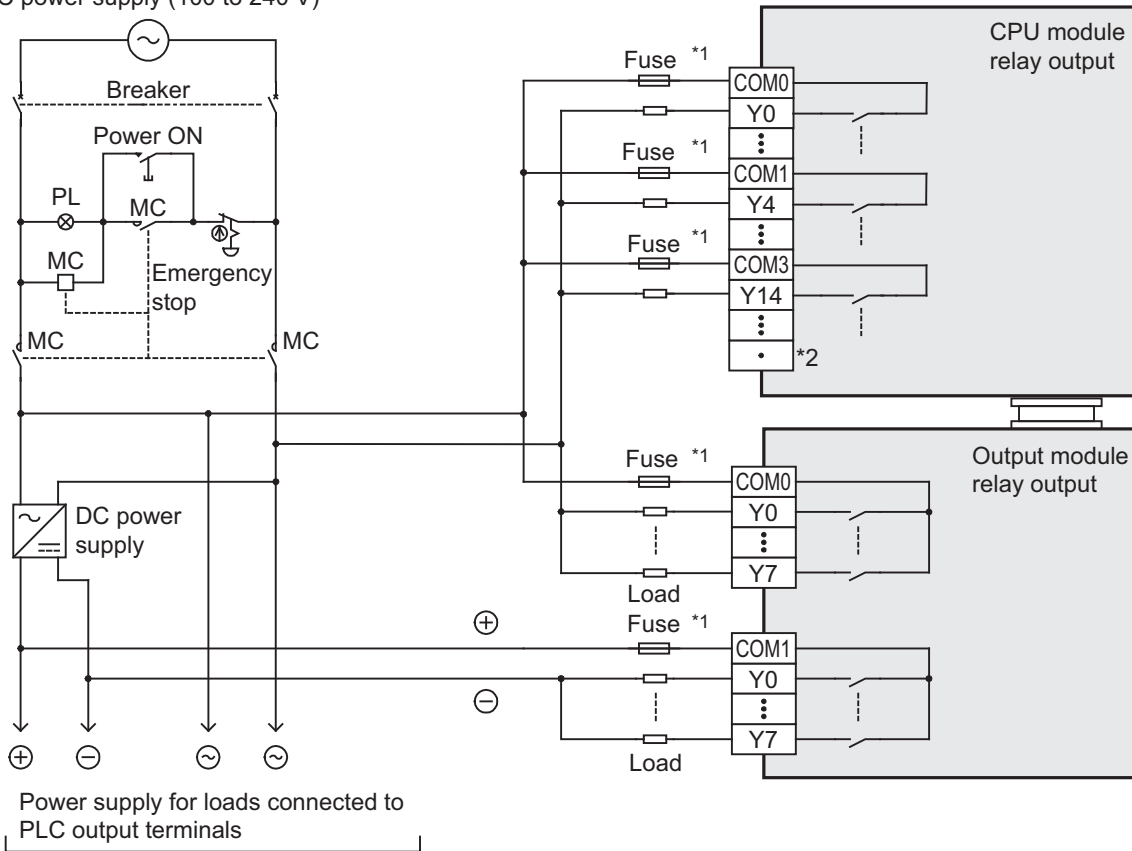

As for emergency stop operation, see "DESIGN PRECAUTIONS" at "Safety Precautions" field.

*1 The output circuit of the PLC does not have a built-in fuse.

Provide a fuse suitable for each load to prevent melting of the wires on the circuit board caused by output device breakdown due to load short-circuiting.

*2 "." represents vacant terminals.

Transistor output

■ Sink output type

AC power supply (100 to 240 V)

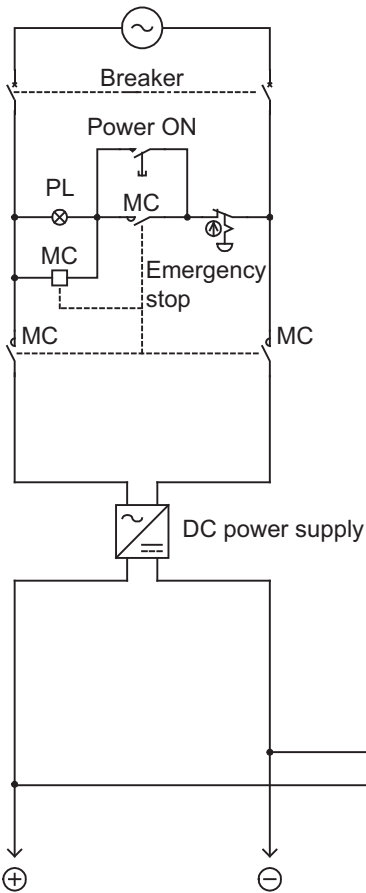

Power supply for loads connected to PLC output terminals

As for emergency stop operation, see "DESIGN PRECAUTIONS" at "Safety Precautions" field.

*1 The output circuit of the PLC does not have a built-in fuse.

Provide a fuse suitable for each load to prevent melting of the wires on the circuit board caused by output device breakdown due to load short-circuiting.

*2 "." represents vacant terminals.

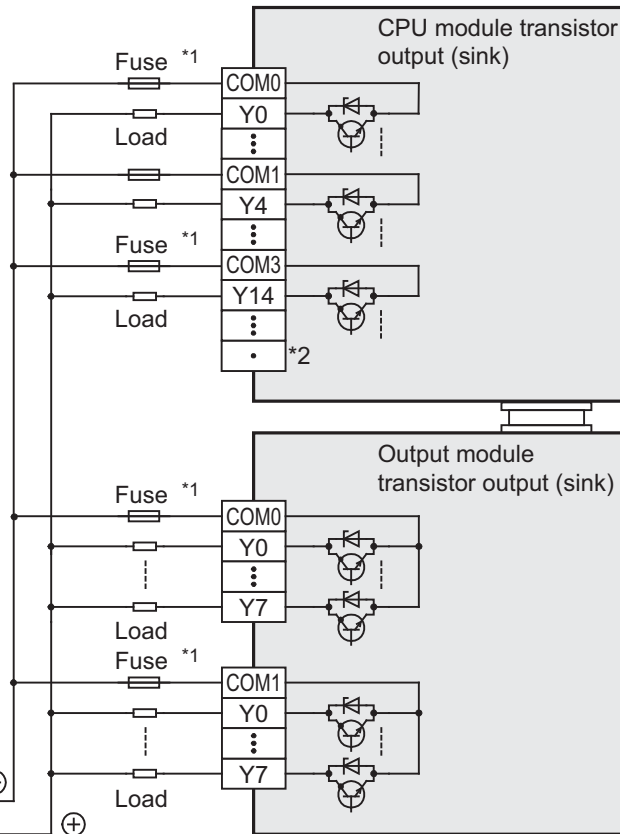

■ Source output type

AC power supply (100 to 240 V)

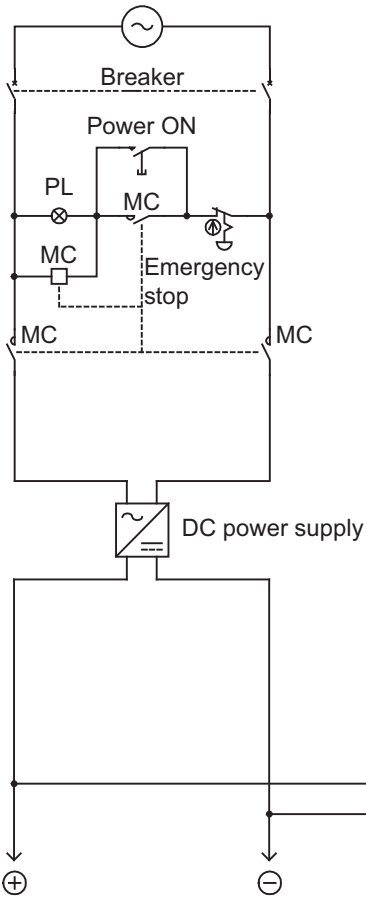

Power supply for loads connected to PLC output terminals

As for emergency stop operation, see "DESIGN PRECAUTIONS" at "Safety Precautions" field.

*1 The output circuit of the PLC does not have a built-in fuse.

Provide a fuse suitable for each load to prevent melting of the wires on the circuit board caused by output device breakdown due to load short-circuiting.

*2 "." represents vacant terminals.

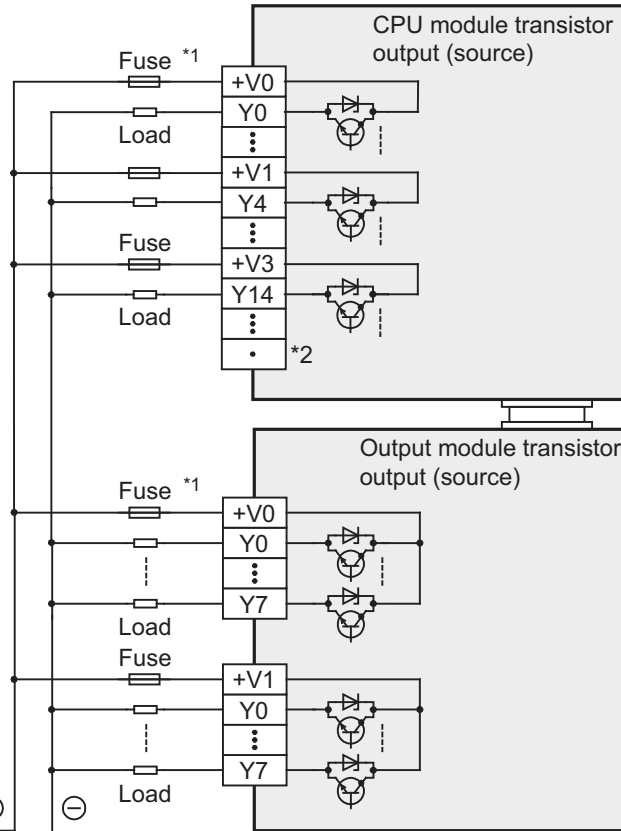

6.7 Analog Wiring

Wiring to the built-in analog I/O terminals of the CPU module is explained below.

For specifications of the built-in analog I/O terminals of the CPU module, refer to  Page 27 Built-in Analog Specifications.

Analog input wiring

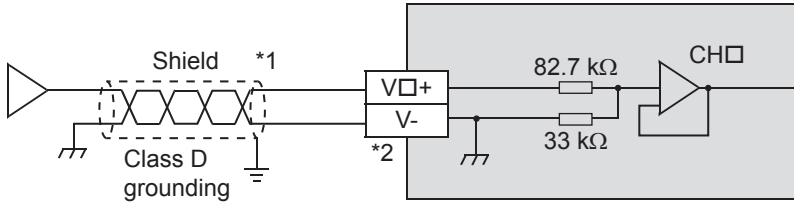

CH No. goes in □ of V□+, CH□.

- *1 For analog input wiring, use shielded twisted-pair cables (double-core type). Separate them from other power lines or lines which can be induced by others.
- *2 For unused channels, short-circuit the "V□+" and "V-" terminals.

Analog output wiring

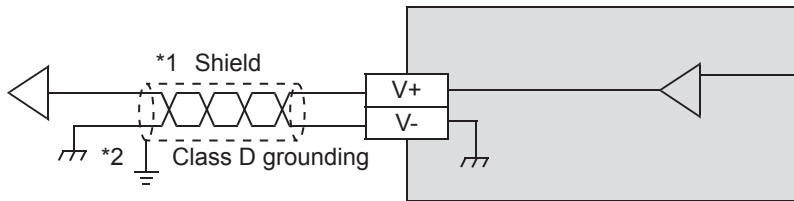

- *1 For analog output wiring, use shielded twisted-pair cables (double-core type). Separate them from other power lines or lines which can be induced by others.
- *2 Ground a shielded cable at one point on the signal receiving side.

6.8 Examples of Wiring for Various Uses

Notes about examples of wiring

The examples of wiring are given under the following conditions.

■Input/output number

The input/output numbers are the actual numbers on the program (They may differ from the numbers shown on the product terminals).

■Input/output specifications of products

Check the input/output specifications of products and examples of wiring.

- There are products for sink output and for source output.

■Examples of program

The examples of programming (instructions) are given based on the allocation of the input/output numbers for wiring.

For the instructions, refer to  MELSEC iQ-F FX5 Series Programming Manual [Instructions, Standard Functions/Function Blocks].

Built-in positioning function

For wiring examples for the built-in positioning function, refer to  MELSEC iQ-F FX5 Series User's Manual [Positioning Control].

Communication function

For wiring of the built-in RS-485 communication terminal block, communication boards and communication adapters, refer to the following.

 MELSEC iQ-F FX5 Series User's Manual [Serial Communication]

 MELSEC iQ-F FX5 Series User's Manual [MODBUS Communication]

For wiring of the built-in Ethernet, refer to the following.

 MELSEC iQ-F FX5 Series User's Manual [Ethernet Communication]

High-speed counter

Examples of wiring for high-speed counters are shown below.

When capturing pulses of a response frequency of 50 to 200 kHz, refer to Page 87 In the case of capturing high-speed pulses.

For details on the high-speed counters, refer to MELSEC iQ-F FX5 Series User's Manual [Application].

For the programs, refer to MELSEC iQ-F FX5 Series Programming Manual [Instructions, Standard Functions/Function Blocks].

1-phase 1-count

The wiring examples in this section use the following settings. When settings other than those in the table are used, use the examples shown in the following figures as references for wiring.

CH to be used	Pulse input mode	External preset input	External enable input	Operation mode
CH1	1-phase 1-input (S/W)	Invalid	Invalid	Normal mode

The settings of the high-speed counters are set by using the parameter settings of the engineering tool.

For details, refer to MELSEC iQ-F FX5 Series User's Manual [Application].

■ Example of wiring (When 24 V DC service power supply is used)

• NPN open collector transistor output rotary encoder

In the case of sink wiring

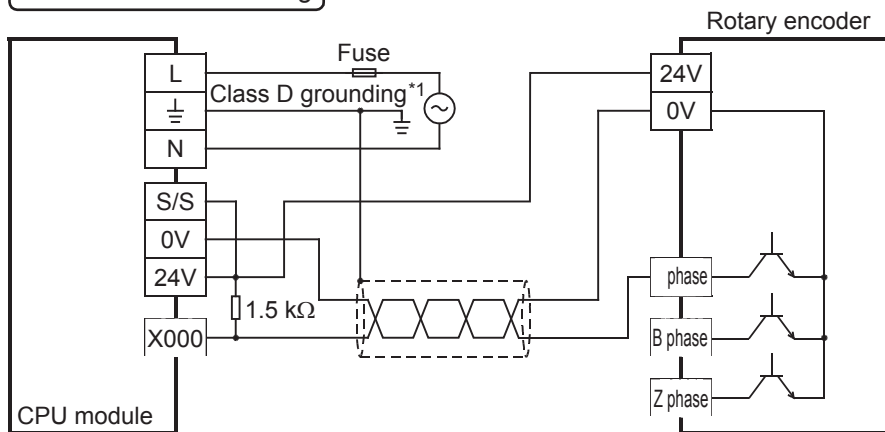

• PNP open collector transistor output rotary encoder

In the case of source wiring

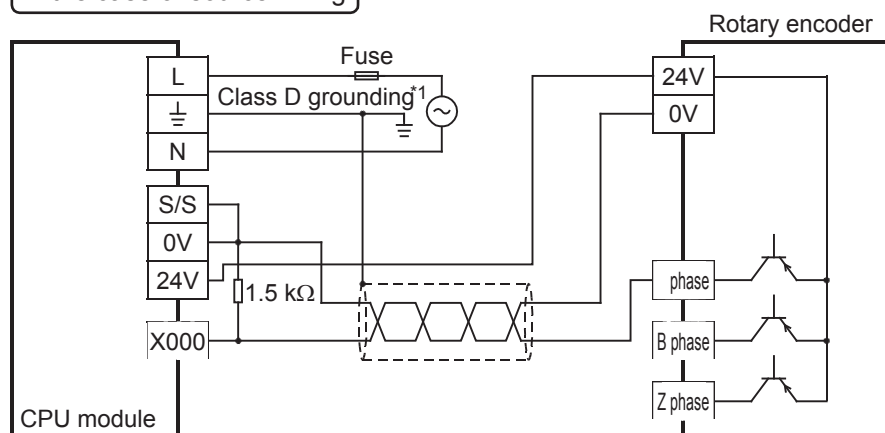

*1 The grounding resistance should be 100 Ω or less.

■ Example of wiring (When 24 V DC external power supply is used)

• NPN open collector transistor output rotary encoder

In the case of sink wiring

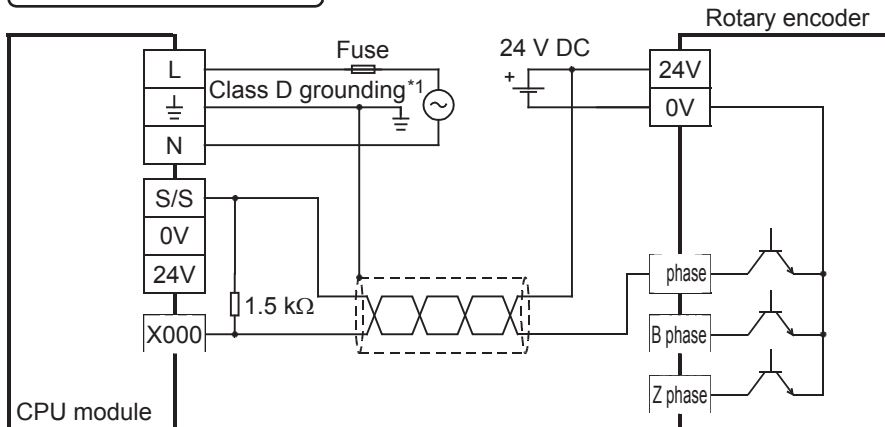

• PNP open collector transistor output rotary encoder

In the case of source wiring

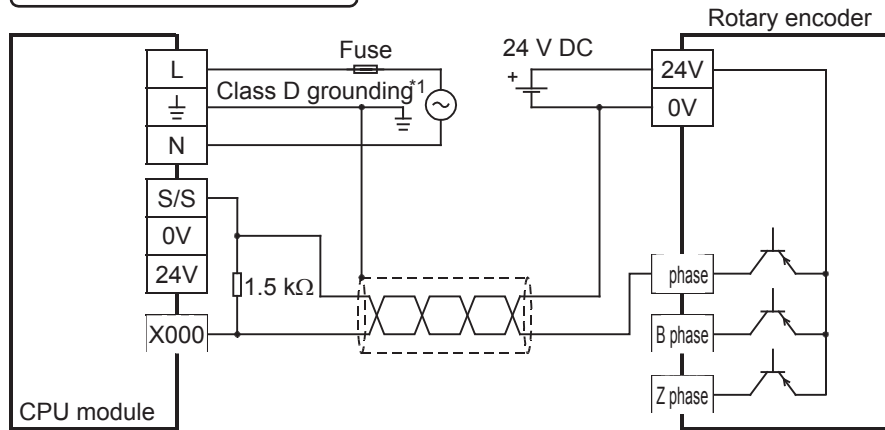

*1 The grounding resistance should be 100 Ω or less.

2-phase 2-count

The wiring examples in this section use the following settings. When settings other than those in the table are used, use the examples shown in the following figures as references for wiring.

CH to be used	Pulse input mode	External preset input	External enable input	Operation mode
CH2	2-phase 2-input	Invalid	Invalid	Normal mode

The settings of the high-speed counters are set by using the parameter settings of the engineering tool.

For details, refer to [GX Works3 Operating Manual](#).

■ Example of wiring (When 24 V DC service power supply is used)

• NPN open collector transistor output rotary encoder

In the case of sink wiring

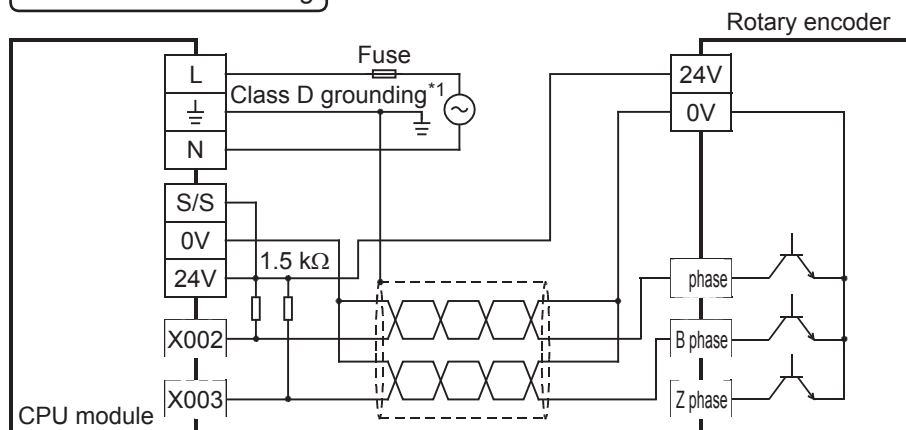

• PNP open collector transistor output rotary encoder

In the case of source wiring

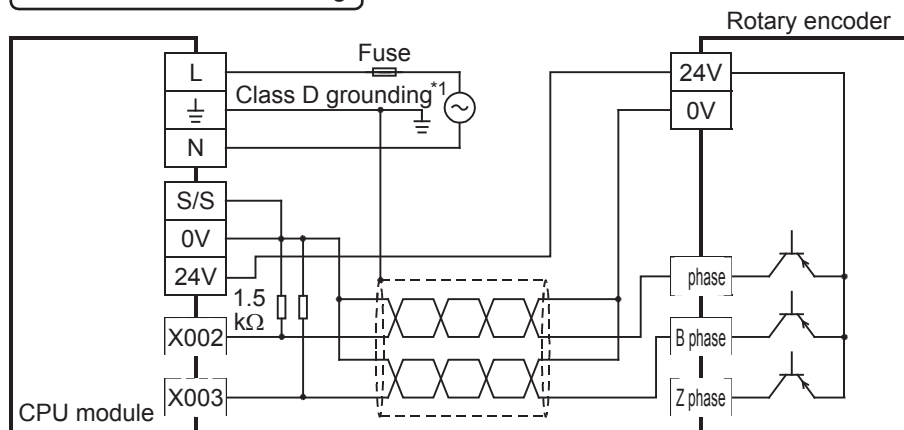

*1 The grounding resistance should be 100 Ω or less.

■ Example of wiring (When 24 V DC external power supply is used)

• NPN open collector transistor output rotary encoder

In the case of sink wiring

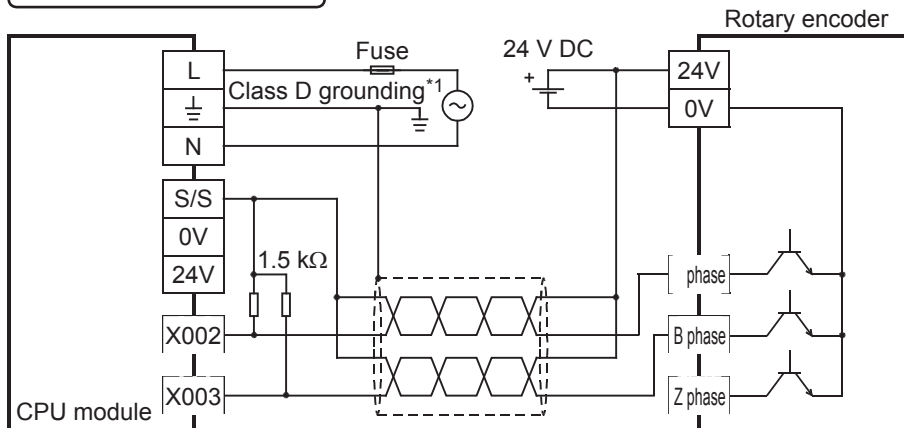

• PNP open collector transistor output rotary encoder

In the case of source wiring

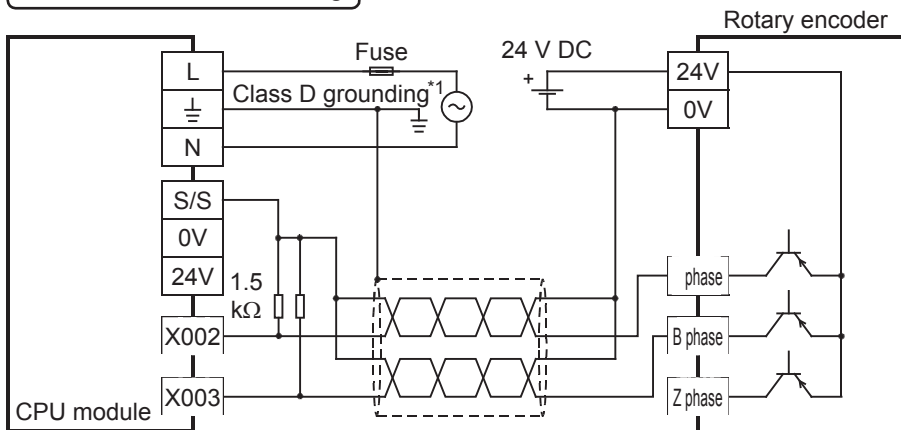

*1 The grounding resistance should be 100 Ω or less.

Interruption

Examples of wiring for when the input interruption function of the CPU module is used are shown below.

The same wiring is used for the pulse catch and pulse width measurement functions.

When capturing pulses of a response frequency of 50 to 200 kHz, refer to Page 87 In the case of capturing high-speed pulses.

For details on the input interruption function, pulse catch function and pulse width measurement function, refer to MELSEC iQ-F FX5 Series User's Manual [Application].

Example of wiring

■When 24 V DC service power supply is used

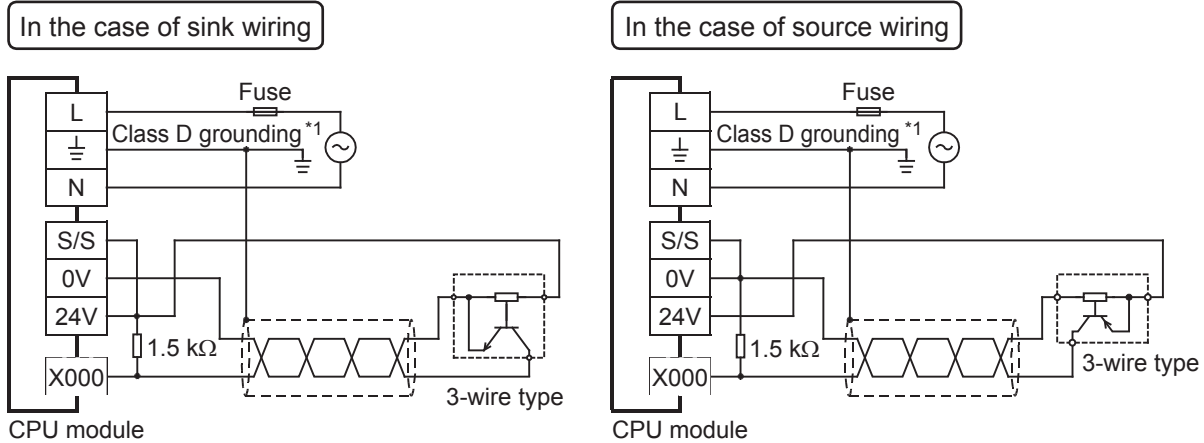

■When 24 V DC external power supply is used

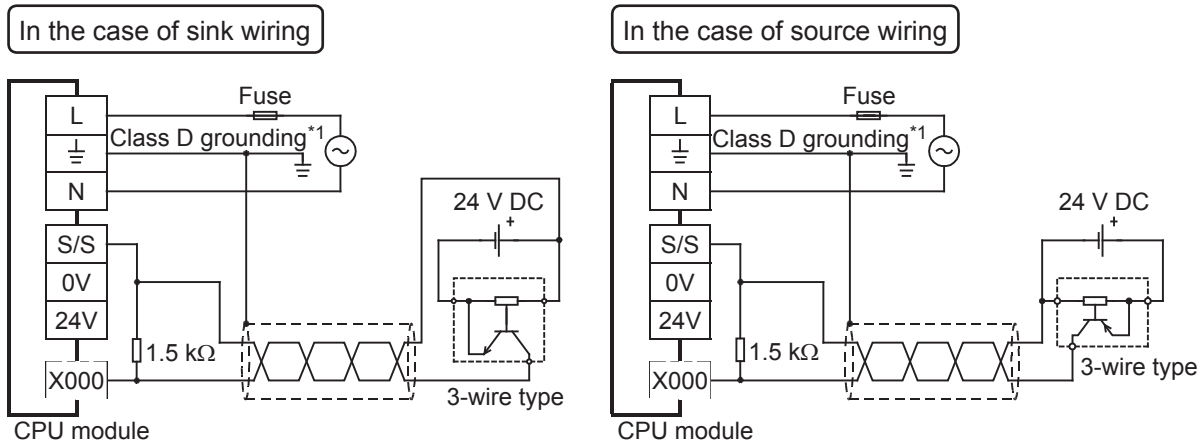

*1 The grounding resistance should be 100 Ω or less.

7 OPERATION ADJUSTMENT

7.1 Preparation for Operation

Preliminary inspection

Incorrect connection of the power supply terminal, contact of the DC input wire and power supply wire, or short-circuiting of output wires may result in serious damage.

Before applying power, check that the power supply and ground terminals are connected correctly and input/output devices are wired properly.

Dielectric withstand voltage test and insulation resistance test

The dielectric withstand voltage and insulation resistance test of the PLC should be measured in accordance with the following procedure.

1. Remove all input/output wires and power supply wires from the PLC.
2. Connect a crossing wire to each of the PLC terminals (power supply terminal, input terminals and output terminals) except the ground terminal. For the dielectric withstand voltage test of each terminal, refer to the generic specifications for the product (refer to  Page 19 Generic Specifications).
3. Measure the dielectric withstand voltage and insulation resistance between each terminal and the ground terminal.
 - Dielectric withstand voltage 1.5 kV AC or 500 V AC for 1 min (The terminals vary in dielectric withstand voltage.)
 - Insulation resistance 10 MΩ or higher by 500 V DC insulation resistance tester

Procedure until operation

The procedure until operation is explained below.

1. Turn on the power of the system.

Check the following items before turning on the power of the system.

- The power supply is wired properly.
- The power supply voltage is within the specified range.
- The CPU module is in the stopped status.

2. Connection with a personal computer

Connect the CPU module with a personal computer on which an engineering tool has been installed.

( Page 108 Connection with a personal computer)

3. Format CPU built-in memory.

Format the CPU built-in memory using the engineering tool.

( GX Works3 Operating Manual)

4. Parameter setting

Set the parameters needed for startup.

( MELSEC iQ-F FX5 Series User's Manual [Application])

( GX Works3 Operating Manual)

- System parameters
- CPU parameters
- Unit parameters

5. Programming

Create a program using the engineering tool. ( MELSEC iQ-F FX5 Series User's Manual [Application])

6. Check the program.

Check for circuit errors and syntax errors with the program check function of the engineering tool.

7. Write the parameters and the program.

Write the parameters and the program set with the engineering tool into the CPU module.

( GX Works3 Operating Manual)

8. Reboot the system.

Reboot the system by any of the following methods.

- Turning off and on the power
- Resetting the CPU module ( Page 110 Resetting method)

9. Check errors.

Check the ERR LED of the CPU module. If an error has occurred, eliminate the cause.

10. Run the program.

Set the CPU module to the RUN status and make sure that the P.RUN LED of the CPU module lights up.

Connection with a personal computer

Connect the CPU module with a personal computer on which an engineering tool has been installed. The system configuration examples and GX Works3 settings are described below. For details, refer to [GX Works3 Operating Manual](#).

Direct connection

Setting examples for accessing the CPU module that is connected directly with a personal computer are shown below.

■ Ethernet connection

- Ethernet port direct connection

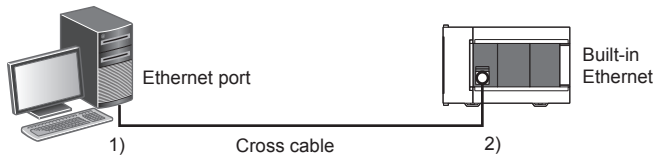

GX Works3 settings

No.	Item	Selection item	Internal setting	Input value
1)	PC side I/F	Ethernet Board	—	—
2)	PLC side I/F	PLC Module		Ethernet Port Direct Connection
	Other Station Setting	No Specification	Check at Communication Time	30 seconds
			Retry Times	0 times

- Connection via HUB

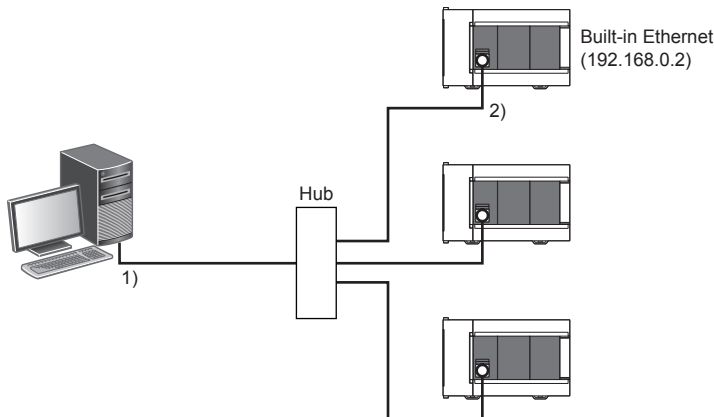

GX Works3 settings

No.	Item	Selection item	Internal setting	Input value
1)	PC side I/F	Ethernet Board	—	—
2)	PLC side I/F	PLC Module	Connection via Hub	IP Address 192.168.0.2
				Response Wait Time 2 seconds
	Other Station Setting	No Specification	Check at Communication Time	30 seconds
			Retry Times	0 times

Serial connection

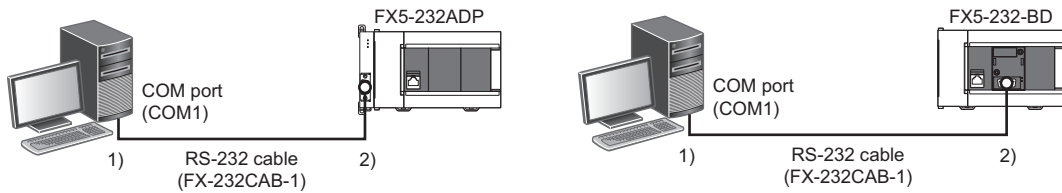

GX Works3 settings

No.	Item	Selection item	Internal setting	Input value
1)	PC side I/F	Serial/USB	RS-232C	—
			COM Port	COM1
			Transmission Speed	115.2Kbps
2)	PLC side I/F	PLC Module	PLC Mode	FX5CPU
	Other Station Setting	No Specification	Check at Communication Time	30 seconds
			Retry Times	0 times

7.2 Operation and Test

Self-diagnostic function

When the power of the CPU module is turned on, the self-diagnostic function to check for errors starts in the module. The CPU module boots when there is no error with the hardware, parameters and program.

When there are no errors, the module enters the RUN status (the P.RUN LED turns on) in response to the RUN instruction (☞ Page 110 Running, Stopping, and Resetting). If any error is detected, the "ERR" LED flashes or lights up.

Monitoring and debugging

The ON/OFF status of PLC's devices, current values or set values can be monitored or changed by using engineering tools. For details, refer to ☞ GX Works3 Operating Manual.

7.3 Running, Stopping, and Resetting

Methods of running, stopping, and resetting

The following two methods of running, stopping, and resetting the FX5U Series modules are provided.

Using the RUN/STOP/RESET switch

The operation status of the CPU module can be changed with the RUN/STOP/RESET switch.

Setting the RUN/STOP/RESET switch to the RUN position runs the program. Setting the switch to the STOP position stops the program.

Resetting method

Resetting can be performed with the RUN/STOP/RESET switch. Resetting is not performed immediately after the RUN/STOP/RESET switch is set to the RESET position.

Perform the following procedure to reset with the RUN/STOP/RESET switch.

1. Set the RUN/STOP/RESET switch (1) to the RESET position for at least one second.
2. Make sure that the ERR LED (2) flashes several times and the light goes off.
3. Return the RUN/STOP/RESET switch to the STOP position.

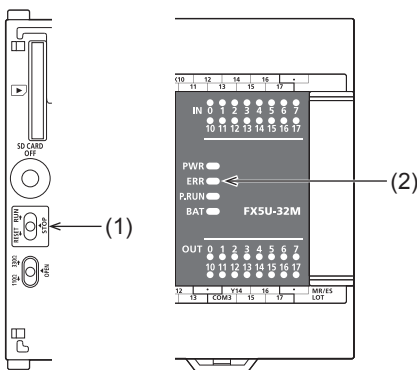

Remote operation

The operation status of the CPU module can be changed externally with the RUN/STOP/RESET switch set to the RUN position. The operation status of the CPU module can be set to the PAUSE status.

Remote operation can be performed by either of the following methods.

- Using contacts (MELSEC iQ-F FX5 Series User's Manual [Application])
- Using engineering tools (GX Works3 Operating Manual)
- Using external devices using SLMP (MELSEC iQ-F FX5 Series User's Manual [SLMP])

Use of several running/stopping methods

When the RUN/STOP/RESET switch and RUN contact are used

- The RUN/STOP status of the PLC is determined by the conditions shown in the following table.



RUN/STOP/RESET switch status	Condition of the input specified as the RUN terminal by parameters	CPU module status
RUN	RUN	RUN
	STOP	STOP
STOP	RUN	STOP
	STOP	STOP

8 MAINTENANCE AND INSPECTION

To keep using the PLC in the optimal condition, perform the following inspections daily or periodically.

8.1 Daily Inspection

Perform the following inspections on a daily basis.

Item	Inspection item	Description	
1	Installation status of the module	Looseness of mounting screws	Retighten the mounting screws.
		Mounting status of the module	The module should be securely mounted.
		Looseness of cover	The cover should not be off.
2	Connection status	Looseness of terminal screws	Retighten the terminal screws.
		Proximity of crimp terminals	Check the proximity between crimp terminals and correct the clearance.
		Looseness of connectors	Connect cable connectors securely.
3	LED status	Check that the LED status is normal.  Page 116 Checking with LEDs  User's manuals for each module	

8.2 Periodic Inspection

Perform the following inspections once or twice every 6 months to a year.

Also perform the inspections when facilities have been relocated or modified or when wiring has been changed.

Item	Inspection item	Description	
1	Ambient environment	Operating ambient temperature	The temperature in the panel should be 0 to 55°C (32 to 131°F).
		Operating ambient humidity	The humidity in the panel should be 5 to 95%RH.
		Working atmosphere	Free from corrosive or flammable gas and excessive conductive dust
2	Power supply voltage	Voltage within the specified range should be supplied.	
3	Installation status	Looseness, rattling	Retighten mounting screws.
		Dirt, foreign matter	Wipe away any dirt or foreign matter. Clean the module.
4	Connection status	Looseness of terminal screws	Retighten the terminal screws.
		Proximity of crimp terminals	Check the proximity between crimp terminals and correct the clearance.
		Looseness of connectors	Connect cable connectors securely.
5	Battery	BAT LED	The BAT LED should be turned off. When the BAT LED lights up, replace the battery with new one.
		Period following the battery purchase	Replace the battery with new one if 5 years or more have passed since the battery was purchased.
		OFF status of SM51 (SM8005), SM52 (SM8006)	SM51 (SM8005) and SM52 (SM8006) should be off. If SM51 (SM8005) and SM52 (SM8006) are on, replace the battery with new one.
6	Relay contacts	Check the product life of relay outputs.  Page 90 Product life of relay output contacts	

Point

The product life of relay contacts varies considerably depending on the load type used. Note that loads generating reverse electromotive force or rush current may cause poor contact or welding of contacts which may lead to considerable reduction of the contact product life.

 Page 90 Product life of relay output contacts

8.3 Battery

Part names

The Latch device memory and clock data upon power interruption. The battery is not incorporated in the CPU module during shipment from the factory. Order it if necessary. Parameter setting is required to back up the device memory and current time. ( Page 113 Setting an optional battery using the engineering tool)

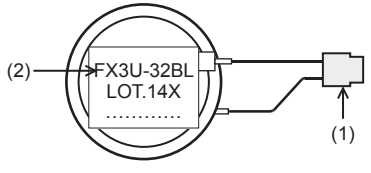
External appearance	No.	Name	Description
	(1)	Connector	Connected to the battery connector of the CPU module.
	(2)	Nameplate	Displays the model name and lot number.

Specifications

The following shows functional specifications of the battery.

Item	FX3U-32BL
Battery type	Lithium manganese dioxide battery
Nominal voltage	3.0 V
Life	Standard life: 5 years (at ambient temperature of 25°C (77°F)) ^{*1}

*1 The life of the battery changes with respect to ambient temperature. ( Page 114 Battery life and replacement guidelines)

Battery attachment

The battery is not incorporated in the CPU module during shipment from the factory. To use the battery, attach it following the procedure below. Parameter setting is required to back up the device memory and current time using the battery. ( Page 113 Setting an optional battery using the engineering tool)

Attachment procedure

1. Turn the power supply off.
2. Remove the expansion board connector cover (A in figure below). If an expansion board is installed, remove it.

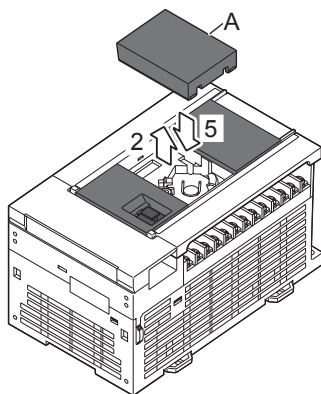

3. Insert the battery connector (B in the figure below) of the battery.
4. Set the battery inside the lower hook (C in the following figure), push up the upper hook (D in the following figure), and then fit the battery in the battery holder (E in the following figure).
The following figure shows the position of the battery.

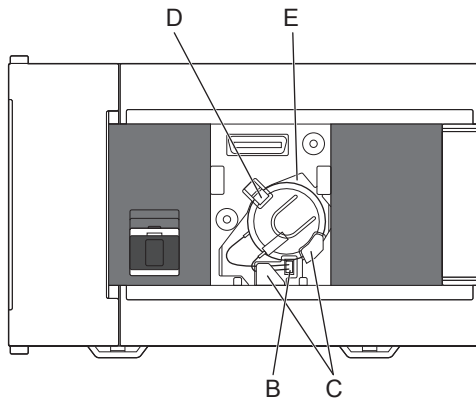

5. Attach the expansion board connector cover. If an expansion board was removed in step 2, reinstall it.

Setting an optional battery using the engineering tool

The following setting is required when the capacity of the latch device/latch label is increased using the optional battery. Note that the battery does not back up the data if the following setting is not provided.

Navigation window ⇒ [Parameter] ⇒ [FX5UCPU] ⇒ [CPU Parameter] ⇒ [Memory/Device Setting] ⇒ [Device/Label Memory Area Setting] ⇒ [Option Battery Setting] ⇒ [Mounted] is chosen.

Item	Setting
Device/Label Memory Area Setting	
Option Battery Setting	Mounted
Device/Label Memory Area Capacity Setting	
Device Area	
Device (high speed) Area Capacity	12 K Word
Device (standard) Area Capacity	35 K Word
Label Area	
Label/Latch Label Use Device Area Setting	Standard Area
Label Area Capacity	12 K Word
Latch Label Area Capacity	1 K Word
Device/Label Memory Area Detailed Setting	
Device (high speed) Setting	<Detailed Setting>
Device (Standard) Setting	<Detailed Setting>
Latch type setting of the latch relay (L)	Latch (1)
Latch Label Latch Type	Latch (1)
Latch area of the latch label	Standard Latch Area

Battery replacement

Battery life and replacement guidelines

When the battery voltage is low, the BAT LED is lit red while the power is on, and SM51 (SM8005) and SM52 (SM8006) are turned ON. The memory can be retained for about one month after the LED is turned on. However, the drop in battery voltage may not be detected immediately. Prepare a new battery and replace the battery with the new one promptly.

Point

Standard life of FX3U-32BL: 5 years (at ambient temperature of 25°C (77°F))

The life of the battery changes with respect to ambient temperature.

When planning for battery replacement, please estimate the battery life according to the graph below and order replacement batteries in advance.

Battery life vs. temperature

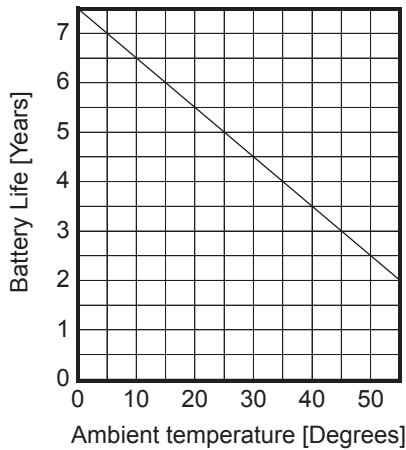

Replacement procedure

If the battery voltage is reduced, replace it following the procedure below.

Even with the battery removed, the built-in capacitor holds the data of the memory for the power interruption time (20 sec.). Battery replacement steps 3 and 4 must be completed within 20 seconds. If the time taken for battery replacement is longer than the power interruption time, the data of the memory may be lost.

1. Turn the power supply off.
2. Remove the expansion board connector cover (A in figure below). If an expansion board is installed, remove it.

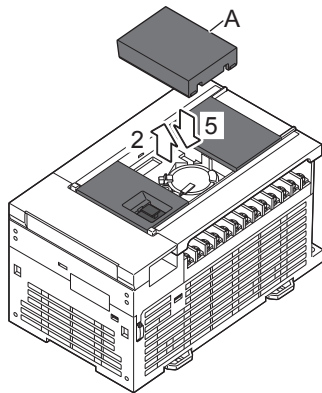

3. Extract the old battery from the battery holder ("B" in figure below), and disconnect the battery connector ("C" in figure below).

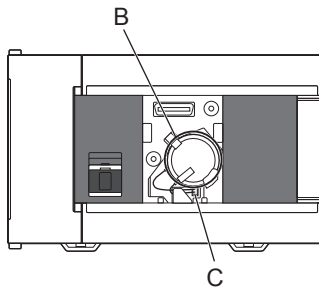

4. Install the new battery. (☞ Page 112 Battery attachment)
5. Attach the expansion board connector cover. If an expansion board was removed in step 2, reinstall it.

Point

- After replacing the battery, check whether the devices set by the latch and clock data are backed up correctly, confirm safety, and then run the PLC.
- If the devices set by the latch are not backed up correctly, clear them, and set their initial values and clock data again if necessary.

Reading the date of manufacture

How to read the battery lot number

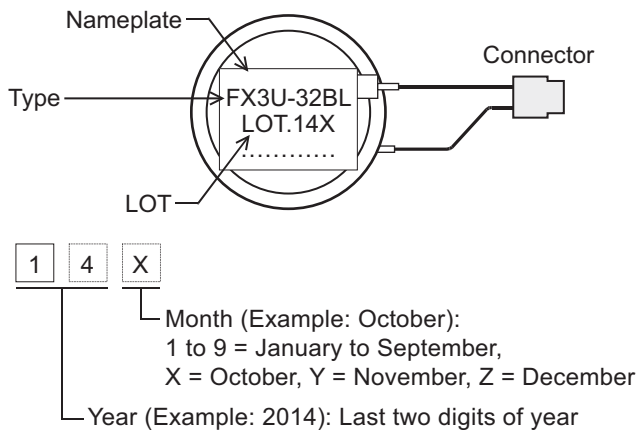

Special relay for low battery voltage

Prepare a system which allows constant external monitoring of the battery status, using a GOT, etc.

- SM52 (SM8005)

The special relay turns ON when the battery voltage is the specified value or less.

The special relay turns OFF when the battery voltage is normal.

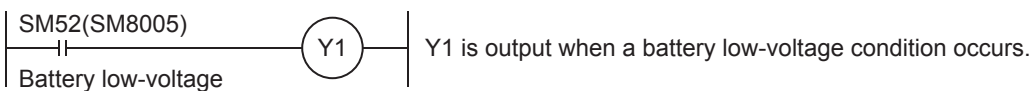

- SM51 (SM8006)

The special relay turns ON when the battery voltage is the specified value or less.

The special relay stays ON even when the battery voltage is normal.

- SD8005

Battery voltage can be monitored.

9 TROUBLESHOOTING



Details on errors occurring in the system, their causes, and corrective actions are explained below.
For details on troubleshooting for each module, refer to the manuals for the module.

Point

Saving the programs and devices used at the occurrence of an error helps in identifying the cause of the error.
( Page 118 Backing Up the Data)

9.1 Troubleshooting Procedure

If an error occurs, perform troubleshooting in the following order.

1. Check that each module is properly mounted and wired.
2. Check the LEDs of the CPU module. ( Page 116 Checking with LEDs)
3. Check the LEDs of each intelligent function module. ( Manuals for each module)
4. Check the cause of the error and take corrective actions.

9.2 Checking with LEDs

Check the module status with LEDs as a means to perform the primary diagnosis.

Checking the PWR LED

If the PWR LED is turned off, check the following items.

Item to check	Cause and action
Measure the voltage input to the CPU module.	If the power source is not supplying the proper voltage, provide a power source that does.
Remove extension modules and all wiring other than the one for the power supply, and turn on the power supply.	If the PWR LED turns on in this condition, the service power supply may be shorted or overloaded. Reconnect the modules and wire one by one to identify the cause.

If the PWR LED still does not turn on even after the items shown above are checked, there may be a hardware issue.
Consult your local Mitsubishi Electric representative.

Checking the BAT LED

If the BAT LED is turned on, check the following items.

The LED is valid when the optional battery is installed and the LED is set to "display" for battery errors by using the parameter.

Item to check	Cause and action
Check the installation of the battery.	Install the battery properly.
Check the battery voltage.	If the battery voltage is reduced, replace the battery with a new one. Battery voltage can be monitored with PLC data register SD8005. ( Page 112 Battery)

Checking the ERR LED

If the ERR LED is turned on

If the ERR LED is turned on, check the following items.

Item to check	Cause and action
Set the CPU module to the STOP status and turn on the power supply again.	When the ERR LED turns off, a watchdog timer error has probably occurred. Take any of the following measures. <ul style="list-style-type: none"> • Review the program and avoid the maximum value (SD524, SD525) of the scan time exceeding the scan time monitoring time setting value set by the parameter. • Check that the input used for input interruption or pulse catch is not being abnormally turned on and off in one scan. • Check that the frequency of the pulse input to the high-speed counter is within the specified range. • Add some WDT instructions to the program and reset the watchdog timer several times in one scan.
Provide a different power supply to the CPU module.	If the ERR LED turns off, noise may have affected the module. Consider taking the following measures. <ul style="list-style-type: none"> • Check the ground wiring, and reexamine the wiring route and installation location. • Fit a noise filter onto the power supply line.

If the ERR LED still does not turn off even after the items shown above are checked, there may be a hardware issue. Consult your local Mitsubishi Electric representative.

Checking the P.RUN LED

If the P.RUN LED is turned off, check the status of the ERR LED and take corrective actions. (☞ Page 117 Checking the ERR LED)

9.3 Error Status and Operations on Occurrence of an Error

When an error occurs, the CPU module performs preconfigured actions depending on the status of the error.

Error status

Errors are classified into the following three types according to the urgency of the errors.

Error status	Program execution status	Description	Required action
Major error	Stop	The module is unable to continue its operation due to a hardware issue.	Perform troubleshooting. If the error still persists, consult your local Mitsubishi Electric representative.
Moderate error	Stop	The module is unable to carry out programs or continue the data communication with stations on the network due to improper program or parameter settings and temporary noise.	To resume the execution of the program or the data communication with the stations on the network, use the engineering tool to identify the cause of the error and take corrective actions.
Minor error	Continue	The module has detected a minor error or alarm. However, the execution of the program and the data communication with the stations on the network continues.	Check the details on the error with the engineering tool. If necessary, take corrective actions for the error.

Operation at the occurrence of an error

Errors are classified into stop errors and continuable errors.

■ Stop error

When a stop error occurs, the CPU module stops operation and enters the STOP status. External outputs of the module follow the "STOP→RUN output mode" settings of parameters.

For details on parameters, refer to  MELSEC iQ-F FX5 Series User's Manual [Application].

■ Continuable error

When a continuable error occurs, the CPU module will keep the operation status and carry out operations.

Only continuable errors can be canceled. When a continuable error is canceled and the CPU module is restored, the CPU module returns to the status before the occurrence of the error. Continuable errors can be canceled by either of the following methods.

- Using engineering tools
- Using special relay (SM) ( Page 119 Canceling Errors)

Operation settings of the CPU module on occurrence of an intelligent function module error

The operation of the CPU module on occurrence of an intelligent function module error can be set with the engineering tool.

Configure the settings with [I/O assignment settings] in the system parameters.

9.4 Backing Up the Data

Saving the following information immediately after the occurrence of an error helps in analyzing the cause of the error.

- Parameters, programs, and device memory
- Error histories

Backing up parameters, programs, and device memory

The procedure for backing up parameters, programs, and device memory using the engineering tool is explained below.

 [Online]⇒[Read from PLC]

1. Check the parameters, programs, and device memory to back up.
2. Click the [Execute] button to read the data.

Backing up devices and buffer memory

The procedure for backing up devices and buffer memory using the engineering tool is explained below.

 [Online]⇒[Read from PLC]

1. Click the "Device memory" check box.
2. Click [Details].
3. Input character strings in "Device data name" and select the devices to back up.
4. Select the "Buffer memory Intelligent module number", and input module number.
5. Click [OK] and then click [Execute] to read the data from the PLC.

9.5 Canceling Errors

Only continuable errors can be canceled.

If an error is canceled and the CPU module is restored, the status of SM, SD, or LEDs returns to the status before the occurrence of the error. After an error is canceled and when the same error occurs again, this error is recorded again in the error history.

When all errors are cancelled at once, annunciators will also be cleared. To clear annunciators individually, use the RST instruction.

Continuable errors can be canceled by the following method.

Using special relays (SM)

Turning on and off SM50, all errors will be canceled.

9.6 Troubleshooting for Each Symptom

When the CPU module does not operate properly, check the appropriate item from the following and perform troubleshooting.

I/O operation (CPU module, I/O module)

Output does not turn on

Item to check	Action
Check for errors with external wiring.	Connect the external wiring properly.
Stop the PLC, and forcibly turn on or off the inoperable output with a peripheral device or the engineering tool.	<ul style="list-style-type: none"> ■When the output operates The output may be turned off unintentionally in the program. Review user program (Duplicate coils or RST instructions). ■When the output does not operate Check the configuration of the connected devices and the connection of the extension cables. If the configuration of the external wiring and connected devices and the connection of the extension cables are acceptable, there may be a hardware issue. Consult your local Mitsubishi Electric representative.

Output does not turn off

Item to check	Action
Check for errors with external wiring.	Connect the external wiring properly.
Stop the PLC and check that the output turns off.	<ul style="list-style-type: none"> ■When the output turns off The output may be turned off unintentionally in the program. Review user program (Duplicate coils or RST instructions). ■When the output does not turn off There may be a hardware fault. Consult your local Mitsubishi Electric representative.

Input does not turn on

Item to check	Action
Disconnect the external wiring and connect the [S/S] terminal and the [0V] terminal or the [24V] terminal. Short-circuit the [0V] terminal or [24V] terminal not connected to the [S/S] terminal and the input terminal, and check the LED or a peripheral device to check that the input turns on.	<ul style="list-style-type: none"> ■When the input turns on Check that the input device does not have a built-in diode or parallel resistance. If so, refer to  Page 86 Precautions for connecting input devices. ■When the input does not turn on Measure the voltage between the [0V] terminal or [24] V terminal not connected to the [S/S] terminal and the input terminal with a tester to check that the voltage is 24 V DC. Check the configuration of the external wiring and connected devices and the connection of the extension cables.

Input does not turn off

Item to check	Action
Check that there is no leakage current from input devices.	If the leakage current is 1.5 mA or more, connect a bleeder resistance. ( Page 86 Precautions for connecting input devices)

PLC write, PLC read

PLC write cannot be performed

If data cannot be written to the CPU module from the engineering tool, check the following items.

Item to check	Action
Check if a password is registered.	Cancel the password registration with the engineering tool.
When a SD memory card is the write destination, check that the write protection is not applied to the card.	Remove the write protection from the SD memory card.  Page 133 SD Memory Card
When a SD memory card is the write destination, check that the card is formatted.	Format the SD memory card.
Check that the size of the write data does not exceed the memory capacity.	<ul style="list-style-type: none">• Ensure sufficient empty capacity.• Clear the memory to which the data is to be written.

PLC read cannot be performed

If data cannot be read from the CPU module to the engineering tool, check the specification of the target memory to be read. Check the memory and reset the CPU module again. Then try PLC read again.

If reading still cannot be performed, there may be a hardware issue. Consult your local Mitsubishi Electric representative.

The program is unintentionally overwritten

The boot operation may be being performed. Read the parameters and review the boot file settings with the engineering tool. If the boot operation is not being performed, there may be a hardware issue. Consult your local Mitsubishi Electric representative.

For details on the boot operation, refer to  MELSEC iQ-F FX5 Series User's Manual [Application].

Boot operation

Boot operation cannot be performed from the SD memory card

Checking item	Action
Check for errors in the CPU module.	Remove the cause of the error.
Check that the file is set in the boot file settings of the parameters.	Set the file in the parameters.
Check that the file is set in the program file settings of the parameters.	
Check that the file to run is stored in the SD memory card.	Store the file to run.

If the boot operation cannot be performed even after the items shown above are checked, there may be a hardware issue. Consult your local Mitsubishi Electric representative.

APPENDIX

Appendix 1 How to Check the Date of Manufacture

Check the date of manufacture of the product (except the expansion board) as follows.

- Nameplate
- Module front surface (CPU module only)

Checking the nameplate

The date of manufacture of the product can be checked from the manufacturer's serial number "S/N" indicated on the nameplate of the product. (For details of the battery, refer to  Page 115 Reading the date of manufacture)

Ex.

CPU module

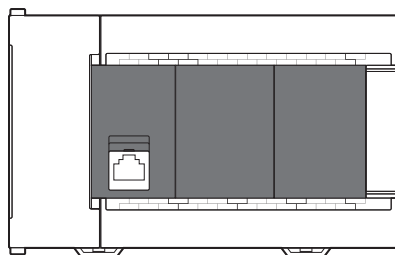

Example nameplate
(manufacturer's serial number: 1490001)

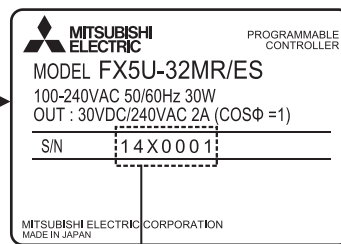

* Actual product nameplate differs from the example shown above.

1 4 X 0 0 0 1

Control number

Month (Example: October):
1 to 9 = January to September,
X = October, Y = November, Z = December

Year (Example: 2014): Last two digits of year

Check on the module front surface

The year and month of production of the product can be checked from the manufacturer's serial number LOT on the front (at the bottom) of the CPU module.

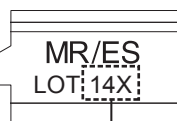
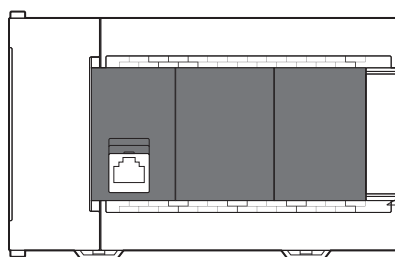

1 4 X

Month (Example: October):
1 to 9 = January to September,
X = October, Y = November, Z = December

Year (Example: 2014): Last two digits of year

Appendix 2 Standards

Certification of UL, cUL standards

FX5 series PLCs supports UL(UL, cUL) standards.

For models that support UL standards, refer to the following.

UL site <http://site.ul.com>

UL, cUL file number: E95239

Compliance with EC directive (CE Marking)

This note does not guarantee that an entire machine produced in accordance with the contents of this note will comply with the following standards.

Compliance to EMC directive and LVD directive of the entire mechanical module should be checked by the user/ manufacturer. For more details please contact to the local Mitsubishi Electric sales site.

Requirement for compliance with EMC directive

The following products have shown compliance through direct testing (of the identified standards below) and design analysis (through the creation of a technical construction file) to the European Directive for Electromagnetic Compatibility (2004/108/EC) when used as directed by the appropriate documentation.

Caution

- This product is designed for use in general industrial applications.

Note

- The manufacturer, manufacturing location, and authorized representative in EU are as follows.

Manufacturer: Mitsubishi Electric Corporation

Address: 2-7-3 Marunouchi, Chiyoda-ku, Tokyo, 100-8310 Japan

Manufacturing location: Mitsubishi Electric Corporation Himeji Works

Address: 840 Chiyoda-machi, Himeji, Hyogo, 670-8677 Japan

Authorized representative in EU: Mitsubishi Electric Europe B.V.

Address: Gothaer Str. 8, 40880 Ratingen, Germany

Product compatibility

Type: Programmable controller (open type equipment)

Models: FX5 series manufactured

from October 1st, 2014	FX5U-32MR/ES	FX5U-32MT/ES	FX5U-32MT/ESS		
	FX5U-64MR/ES	FX5U-64MT/ES	FX5U-64MT/ESS		
	FX5U-80MR/ES	FX5U-80MT/ES	FX5U-80MT/ESS		
	FX5-8EX/ES	FX5-8EYR/ES	FX5-8EYT/ES	FX5-8EYT/ESS	
	FX5-16EX/ES	FX5-16EYR/ES	FX5-16EYT/ES	FX5-16EYT/ESS	
	FX5-32ER/ES	FX5-32ET/ES	FX5-32ET/ESS		
	FX5-232ADP	FX5-485ADP	FX5-232-BD	FX5-485-BD	FX5-422-BD-GOT
	FX5-1PSU-5V	FX5-CNV-BUS			

Electromagnetic compatibility (EMC) directive	Remarks
EN61131-2:2007 Programmable controllers - Equipment requirements and tests	Compliance with all relevant aspects of the standard. EMI • Radiated emission • Conducted emission EMS • Radiated electromagnetic field • Fast transient burst • Electrostatic discharge • High-energy surge • Voltage drops and interruptions • Conducted RF • Power frequency magnetic field

Requirement for compliance with LVD directive

The following products have shown compliance through direct testing (of the identified standards below) and design analysis (through the creation of a technical construction file) to the European Directive for Low Voltage (2006/95/EC) when used as directed by the appropriate documentation.

Type: Programmable controller (open type equipment)

Models: FX5 series manufactured

from October 1st, 2014	FX5U-32MR/ES	FX5U-32MT/ES	FX5U-32MT/ESS
	FX5U-64MR/ES	FX5U-64MT/ES	FX5U-64MT/ESS
	FX5U-80MR/ES	FX5U-80MT/ES	FX5U-80MT/ESS
	FX5-8EYR/ES	FX5-16EYR/ES	
	FX5-32ER/ES	FX5-32ET/ES	FX5-32ET/ESS
	FX5-1PSU-5V		

Electromagnetic compatibility (EMC) directive	Remarks
EN61131-2:2007 Programmable controllers - Equipment requirements and tests	The equipment has been assessed as a component for fitting in a suitable enclosure which meets the requirements of EN61131-2:2007.

Caution for compliance with EC Directive

Installation in enclosure

PLCs are open-type devices that must be installed and used within shielded conductive control boxes.

Please use the FX5 series PLCs while installed in conductive shielded control boxes. Please secure the control box lid to the control box (for conduction). Installation within a control box greatly improves the safety of the system and aids in shielding noise from the PLC.

Caution for when analog products are used

It is recommended to perform the following when precision of measuring and control is required.

As analog devices are sensitive by nature, their use should be considered carefully. For users of proprietary cables (integral with sensors or actuators), these users should follow those manufacturers' installation requirements.

Mitsubishi Electric recommends that shielded cables be used. If no other EMC protection is provided, users may experience temporary loss of accuracy between +10%/-10% in very heavy industrial areas.

However, Mitsubishi Electric suggests that if adequate EMC precautions are followed with general good EMC practice for the user's complete control system, users should expect normal errors as specified in this manual.

- Sensitive analog cables should not be laid in the same trunking or cable conduit as high voltage cabling. Where possible, users should run analog cables separately.
- Good cable shielding should be used. When terminating the shield at Earth - ensure that no earth loops are accidentally created.
- When reading analog values, EMC induced errors can be smoothed out by averaging the readings. This can be achieved either through functions on the analog special adapters/blocks or through a user's program in the FX5U Series PLC main unit.

Caution for when the built-in Ethernet port is used

- Use a shielded twisted pair cable for the 10BASE-T or 100BASE-TX cable. Strip a part of the jacket of the shielded twisted pair cable as shown below and ground as much of the exposed shield as possible to both sides of the cable.
- Connect a ferrite core to both ends of the cable. (Ferrite core used in tests by Mitsubishi: ZCAT2035-0930A manufactured by TDK Co.)

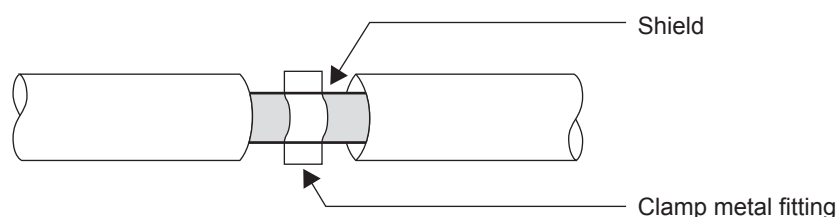

Appendix 3 I/O Module

Product configuration

There are various types of I/O module. They differ in supply voltage, number of input/output points, input form, output form and connection type.

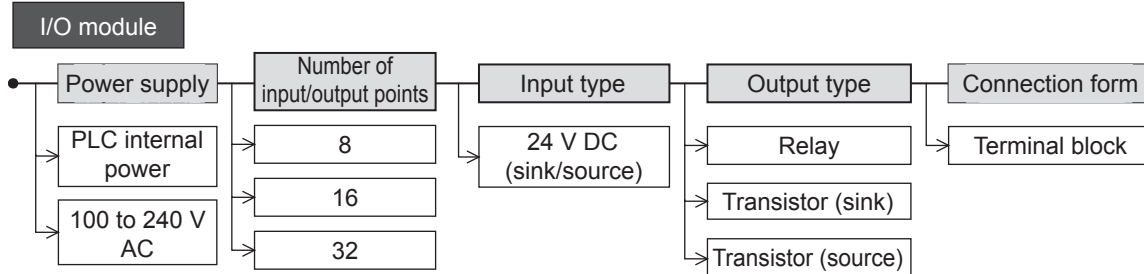

Product list

Input modules

Sink : Sink, Source : Source

Model	Input			Output			Connection type
	Type	No. of points	Common wiring system	Type	No. of points	Common wiring system	
■Common to input extension/sink and source input							
FX5-8EX/ES	24 V DC	8	<input type="checkbox"/> Sink <input checked="" type="checkbox"/> Source	—	—	—	Terminal block
FX5-16EX/ES	24 V DC	16	<input type="checkbox"/> Sink <input checked="" type="checkbox"/> Source	—	—	—	Terminal block

Output module

Sink : Sink, Source : Source

Model	Input			Output			Connection type
	Type	No. of points	Common wiring system	Type	No. of points	Common wiring system	
■Output extension/relay output type							
FX5-8EYR/ES	—	—	—	Relay	8	—	Terminal block
FX5-16EYR/ES	—	—	—	Relay	16	—	Terminal block
■Output extension/dedicated to sink output only							
FX5-8EYT/ES	—	—	—	Transistor	8	<input type="checkbox"/> Sink	Terminal block
FX5-16EYT/ES	—	—	—	Transistor	16	<input type="checkbox"/> Sink	Terminal block
■Output extension/dedicated to source output only							
FX5-8EYT/ESS	—	—	—	Transistor	8	<input checked="" type="checkbox"/> Source	Terminal block
FX5-16EYT/ESS	—	—	—	Transistor	16	<input checked="" type="checkbox"/> Source	Terminal block

Powered input/output module

Sink : Sink, Source : Source

Model	Input			Output			Connection type
	Type	No. of points	Common wiring system	Type	No. of points	Common wiring system	
■Input/output extension/sink and source input/relay output type							
FX5-32ER/ES	24 V DC	16	<input type="checkbox"/> Sink <input checked="" type="checkbox"/> Source	Relay	16	—	Terminal block
■Input/output extension/sink and source input/dedicated to sink output only							
FX5-32ET/ES	24 V DC	16	<input type="checkbox"/> Sink <input checked="" type="checkbox"/> Source	Transistor	16	<input type="checkbox"/> Sink	Terminal block
■Input/output extension/sink and source input/dedicated to source output only							
FX5-32ET/ESS	24 V DC	16	<input type="checkbox"/> Sink <input checked="" type="checkbox"/> Source	Transistor	16	<input checked="" type="checkbox"/> Source	Terminal block

Specifications

The generic specifications are the same as those for the CPU module. ( Page 19 Generic Specifications)

Power supply specifications

■Input modules

Item	Specifications
Voltage rating	24 V DC (supplied from service power supply or external power supply) 5 V DC (supplied from PLC)
Current consumption (5 V DC)	FX5-8EX/ES 75 mA
	FX5-16EX/ES 100 mA
Current consumption (24 V DC)	FX5-8EX/ES 50 mA
	FX5-16EX/ES 85 mA

■Output modules

Item	Specifications
Voltage rating	24 V DC (supplied from service power supply or external power supply) 5 V DC (supplied from PLC)
Current consumption (5 V DC)	FX5-8EY□ 75 mA
	FX5-16EY□ 100 mA
Current consumption (24 V DC)	FX5-8EY□ 50 mA
	FX5-16EY□ 85 mA

■Powered input/output module(FX5-32E□)

Item	Specifications
Voltage rating	100 to 240 V AC
Allowable supply voltage range	85 to 264 V AC
Rated frequency	50/60 Hz
Allowable instantaneous power failure time	Operation can be continued upon occurrence of instantaneous power failure for 10 ms or less.
Power fuse	250 V, 3.15 A time-lag fuse
Rush current	30 A max. 5 ms or less/100 V AC 65 A max. 5 ms or less/200 V AC
Power consumption*1	25 W
24 V DC service power supply*2	250 mA (Supply capacity when service power supply is used for input circuit of the powered input/output module)
	310 mA (Supply capacity when external power supply is used for input circuit of the powered input/output module)
5 V DC power supply	965 mA

*1 This item shows value when all 24 V DC service power supplies are used in the maximum configuration connectable to the CPU module. (The current of the input circuit is included.)

*2 When I/O modules are connected, they consume current from the 24 V DC service power. For details on the service power supply, refer to  Page 49 Limitation on Current Consumption.

External color, weight, accessories

■ Input module/output module

Item		Specifications
External color		Munsell 0.6B7.6/0.2
Mass (weight)	FX5-8E□	Approx. 0.2 kg (0.44 lbs)
	FX5-16E□	Approx. 0.25 kg (0.55 lbs)
Accessories		Dust proof protection sheet

■ Powered input/output module (FX5-32E□)

Item		Specifications
External color		Munsell 0.6B7.6/0.2
Mass (weight)		Approx. 0.65 kg (1.43 lbs)
Accessories		Extension cable, dust proof protection sheet

Input specifications

There is the simultaneous ON ratio of available PLC inputs or outputs with respect to the ambient temperature.

For details, refer to  Page 24 Input/Output Derating Curve

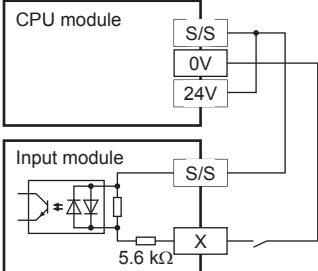
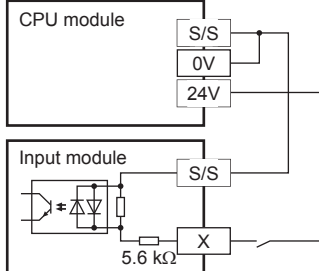
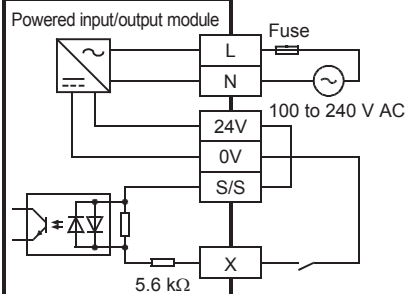
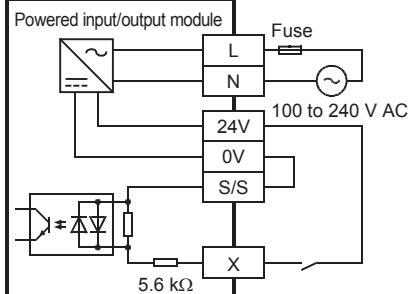
Item		Specifications
No. of input points	FX5-8EX/ES	8 points
	FX5-16EX/ES	16 points
	FX5-32E□	16 points
Connection type		Terminal block (M3 screws)
Input type		Sink/source
Input signal voltage		24 V DC +20%, -15%
Input signal current		4 mA/24 V DC
Input impedance		5.6 kΩ
Input sensitivity current	ON	3.0 mA or more
	OFF	1.5 mA or less
Input response time		ON: 50 μs or less OFF: 150 μs or less
Input signal format		No-voltage contact input Sink: NPN open collector transistor Source: PNP open collector transistor
Input circuit insulation		Photo-coupler insulation
Indication of input operation		LED is lit when input is on
Input circuit configuration		<ul style="list-style-type: none"> When using service power supply by input module <div style="display: flex; justify-content: space-around;"> <div style="text-align: center;"> <p>Sink input wiring</p>  </div> <div style="text-align: center;"> <p>Source input wiring</p>  </div> </div> When using service power supply by powered input/output module <div style="display: flex; justify-content: space-around;"> <div style="text-align: center;"> <p>Sink input wiring</p>  </div> <div style="text-align: center;"> <p>Source input wiring</p>  </div> </div>

Item	Specifications
Input circuit configuration	<ul style="list-style-type: none"> When using service power supply by input module <div style="display: flex; justify-content: space-around;"> <div style="text-align: center;"> <p>Sink input wiring</p> </div> <div style="text-align: center;"> <p>Source input wiring</p> </div> </div> When using service power supply by powered input/output module <div style="display: flex; justify-content: space-around;"> <div style="text-align: center;"> <p>Sink input wiring</p> </div> <div style="text-align: center;"> <p>Source input wiring</p> </div> </div>

Output specifications

There is the simultaneous ON ratio of available PLC inputs or outputs with respect to the ambient temperature. For details, refer to [Page 24 Input/Output Derating Curve](#)

Relay output

Item	Specifications	
No. of output points	FX5-8EYR/ES	8 points
	FX5-16EYR/ES	16 points
	FX5-32ER/ES	16 points
Connection type	Terminal block (M3 screws)	
Output type	Relay	
External power supply	30 V DC or less 240 V AC or less (250 V AC or less when the module does not comply with CE UL, cUL standards)	
Output circuit insulation	Mechanical insulation	
Indication of output operation	LED is lit when output is on	
Max. load	2 A/point The total load current of resistance loads per common terminal should be the following value. <ul style="list-style-type: none"> 4 output points/common terminal: 8 A or less 8 output points/common terminal: 8 A or less 	
Open circuit leakage current	—	
Min. load	5 V DC, 2 mA (reference values)	
Response time	OFF→ON	Approx. 10 ms
	ON→OFF	Approx. 10 ms
Output circuit configuration		

■ Transistor output (sink output)

Item		Specifications
No. of output points	FX5-8EYT/ES	8 points
	FX5-16EYT/ES	16 points
	FX5-32ET/ES	16 points
Connection type		Terminal block (M3 screws)
Output type		Transistor/sink output
External power supply		5 to 30 V DC
Output circuit insulation		Photo-coupler insulation
Indication of output operation		LED is lit when output is on
Max. load		0.5 A/point The total load current of resistance loads per common terminal should be the following value. <ul style="list-style-type: none"> • 4 output points/common terminal: 0.8 A or less • 8 output points/common terminal: 1.6 A or less
Open circuit leakage current		0.1 mA/30 V DC
Min. load		—
Response time	OFF→ON	0.2 ms or less/200 mA (at 24 V DC)
	ON→OFF	0.2 ms or less/200 mA (at 24 V DC)
Voltage drop when ON		1.5 V or less
Output circuit configuration		

■ Transistor output (source output)

Item		Specifications
No. of output points	FX5-8EYT/ESS	8 points
	FX5-16EYT/ESS	16 points
	FX5-32ET/ESS	16 points
Connection type		Terminal block (M3 screws)
Output type		Transistor/source output
External power supply		5 to 30 V DC
Output circuit insulation		Photo-coupler insulation
Indication of output operation		LED is lit when output is on
Max. load		0.5 A/point The total load current of resistance loads per common terminal should be the following value. <ul style="list-style-type: none"> • 4 output points/common terminal: 0.8 A or less • 8 output points/common terminal: 1.6 A or less
Open circuit leakage current		0.1 mA/30 V DC
Min. load		—
Response time	OFF→ON	0.2 ms or less/200 mA (at 24 V DC)
	ON→OFF	0.2 ms or less/200 mA (at 24 V DC)
Voltage drop when ON		1.5 V or less
Output circuit configuration		

External dimensions and component names

Input module/output module

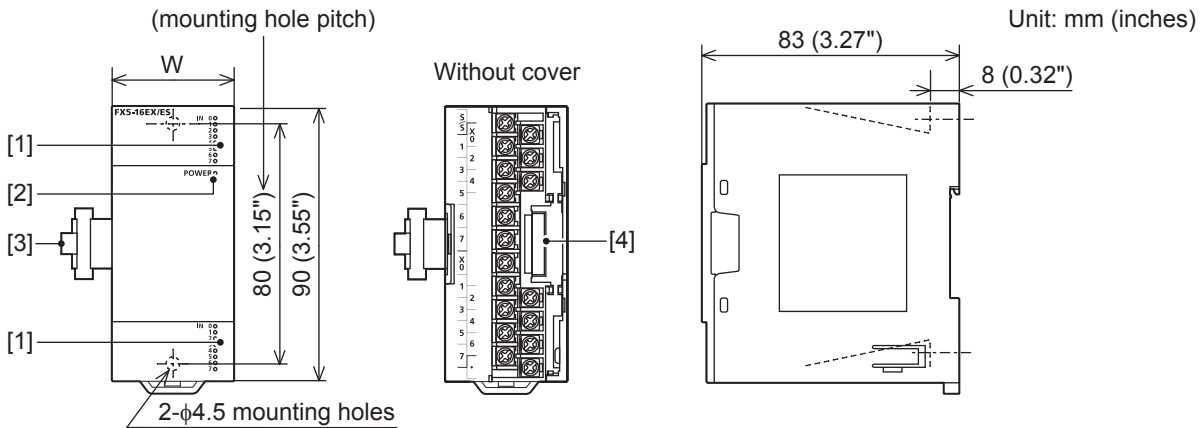

External dimensions

Model	W: mm (inches)
FX5-8EX/ES	40 (1.58")
FX5-8EYR/ES, FX5-8EYT/ES, FX5-8EYT/ESS	
FX5-16EX/ES	
FX5-16EYR/ES, FX5-16EYT/ES, FX5-16EYT/ESS	

Part names

No.	Name	Description
[1]	Input display LED, output display LED	Lit when input or output is on.
[2]	POWER LED	Indicates whether the input modules/output modules is powered or not. Lit: Powered Off: Not powered or hardware error
[3]	Pullout tab	They are used when drawing out an extension cable.
[4]	Extension connector	Connector for connecting the extension cable of an extension module.

Powered input/output module

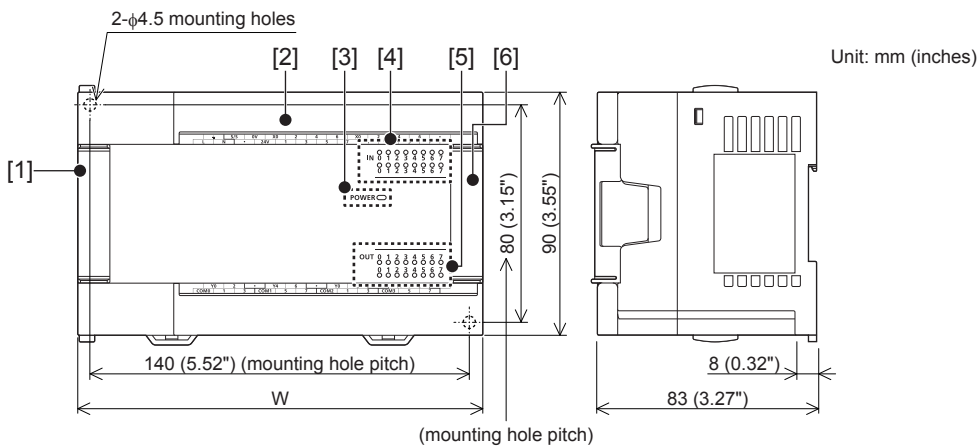

[Without cover]

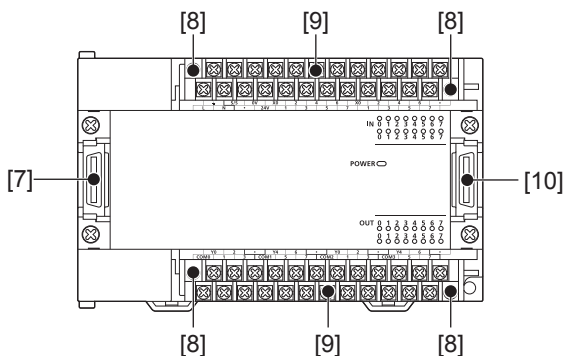

External dimensions

Model	W: mm (inches)
FX5-32ER/ES, FX5-32ET/ES, FX5-32ET/ESS	150 (5.91")

Part names

No.	Name	Description
[1]	Extension connector cover (for preceding module)	Cover for protecting the extension connector cover (for preceding module).
[2]	Terminal block cover	Cover for protecting the terminal block. The cover can be opened for wiring. Keep the covers closed while equipment is running (power is on).
[3]	POWER LED	Indicates whether the powered input/output module is powered or not. Lit: Powered Off: Not powered or hardware error
[4]	Input display LED	Lit when input is on.
[5]	Output display LED	Lit when output is on.
[6]	Extension connector cover (for next module)	Cover for protecting the extension connector cover (for next module).
[7]	Extension connector (for preceding module)	Connector for connecting the supplied extension cable that connects to the preceding module (the CPU module side).
[8]	Terminal block mounting screws	Gradually loosen the left and right screws (alternatingly) to remove the upper part of the terminal block.
[9]	Terminal	Terminals for power, input, and output. For details on the terminal layout, refer to Page 132 Terminal layout
[10]	Extension connector (for next module)	Connector for connecting the extension cable of an extension module.

Terminal layout

FX5-8EX/ES



FX5-16EX/ES

FX5-8EYR/ES
FX5-8EYT/ES

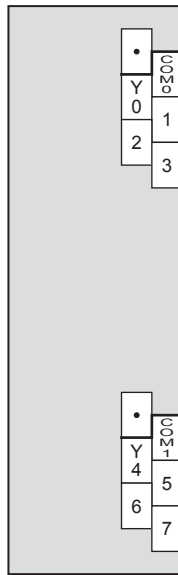

FX5-16EYR/ES
FX5-16EYT/ES

FX5-8EYT/ESS

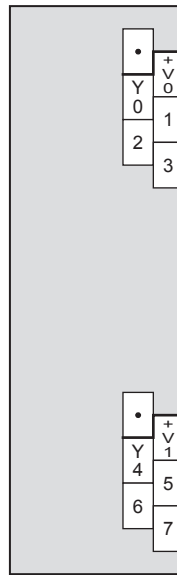

FX5-16EYT/ESS

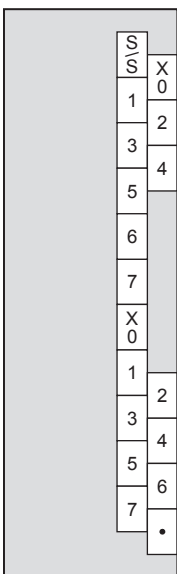

FX5-32E□

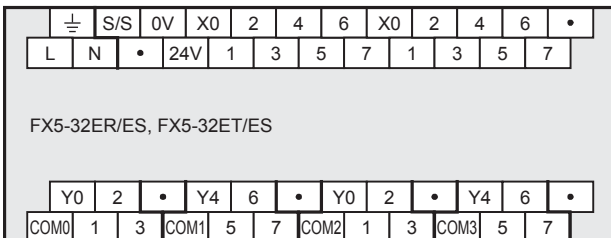
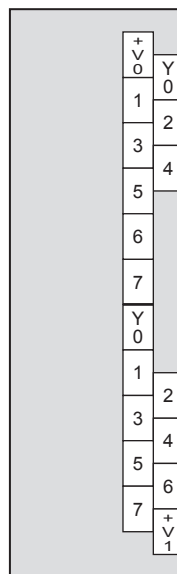
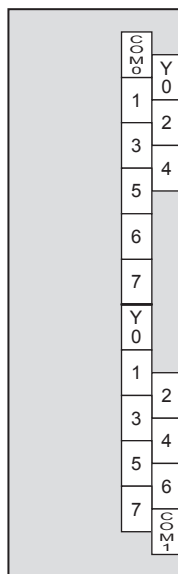

FX5-32ET/ESS

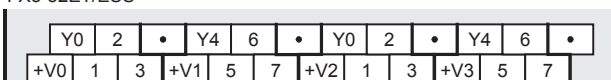

Appendix 4 SD Memory Card

Part names

An SD memory card is installed in the CPU module to operate the module based on the project data in the card.

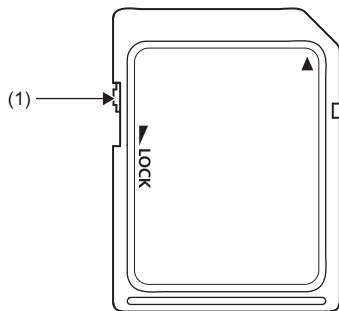

No.	Name	Description
(1)	Protect switch	Setting the switch in the lock position prevents the data in the SD memory card from being deleted and overwritten.

Specifications

The following shows functional specifications of the SD memory card.

Item	L1MEM-2GBSD	L1MEM-4GBSD
Type	SD memory card	SDHC memory card
Capacity	2 Gbytes	4 Gbytes
File storage capacity	511 ^{*1}	65534 ^{*1}
No. of removals/insertions	500 or less	
External dimensions	Height	32 mm (1.25")
	Width	24 mm (0.94")
	Depth	2.1 mm (0.08")
Mass (weight)	2 g	

*1 The value listed above indicates the number of files stored in the root folder.

Handling of the SD memory card

- Use a Mitsubishi SD memory card (L1MEM-2GBSD or L1MEM-4GBSD). Use of SD memory card other than a Mitsubishi SD memory card may result in loss of the data stored in the SD memory card, or problems such as system stop.
- When mounted in the CPU module, L1MEM-2GBSD and L1MEM-4GBSD are compliant with IEC61131-2.
- The SDHC memory card can be used only with devices with an SDHC logo or whose user's manual lists an SDHC logo. Note that SDHC cards cannot be used with devices that support only "SD" specifications.
- Turning off or resetting the CPU module or removing the SD memory card while the card is being accessed may corrupt the data in the SD memory card. Always turn off or reset the CPU module or remove the SD memory card after disabling access to the SD memory card. With SM606 (SD memory card forced disable instruction) and SM607 (SD memory card forced disable status flag), the SD memory card can be disabled and its usage status can be checked.
- It is recommended that important data be periodically backed up to CD, DVD, or other media.

Formatting

To use any SD memory card in the CPU module, the card must be formatted. In the initial state after purchase, the SD memory card is not formatted. Insert the SD memory card to a CPU module and format the SD memory card using the engineering tool before use. Do not format the SD memory card using the personal computer. (IGX Works3 Operating Manual)

Insertion and removal of the SD memory card

The following explains insertion and removal of the SD memory card.

Insertion procedure

Mount the SD memory card. Pay attention to the direction of the card and follow the procedure below.

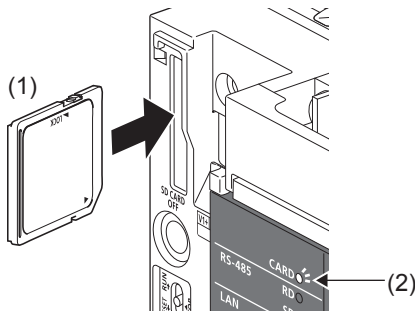

1. Insert the SD memory card (1) straight into the SD memory card slot. Make sure that the notch of the card is directed downward. After mounting, check that the card is mounted completely. If the card is mounted incompletely, malfunctions may occur because of poor contact.
2. The CARD LED (2) blinks until the SD memory card becomes available.
3. The CARD LED turns on when the SD memory card is available.
4. If the CARD LED does not turn on even though the SD memory card is mounted, make sure that SM606 (forcibly stop using SD memory card instruction) and SM607 (forcibly stop using SD memory card flag) are OFF by using engineering tools.

Removal procedure

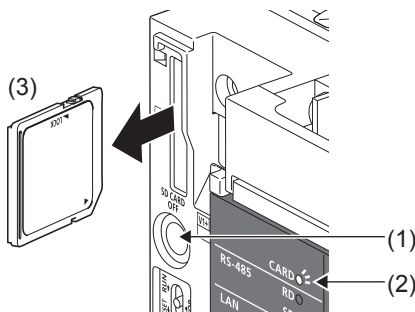

1. Press the SD memory card stop switch (1) for one second or more to stop access to the card. The CARD READY LED (2) blinks during the access stop operation, and then the LED is turned OFF when the operation is completed.
2. Insert the SD memory card (3) once, and then pull it straight.

Precautions

- When mounting or removing the SD memory card while the power is ON, follow the above-mentioned procedure. Otherwise, the data in the card may be broken.
- When removing the SD memory card which is being accessed by any function, the CARD LED is turned OFF after the access is completed. When the CARD LED is turned OFF depends on the accessing function.
- When SM605 (mount and remove memory card disabling flag) is ON, the CARD LED is not turned OFF even if the SD memory card stop switch is pressed. If the CARD LED is not turned OFF, turn ON SM606 (instruction of forcibly stop using SD memory card) so that the SD memory card cannot be used.

Appendix 5 Precautions for Battery Transportation

When transporting lithium batteries, follow required transportation regulations.
Batteries used in the FX5U series CPU module are classified as follows.

Control-subject product

Built-in

None (FX5U series CPU modules do not include batteries when shipped from the factory.)

Battery only (spare parts and optional parts)

Model	Battery type	Product form	Lithium contained (g/battery)	Weight ^{*1} (g/battery)
FX3U-32BL	Lithium-metal battery	Cell	0.15	30

*1 Weight in packaging.

Precautions for transportation

When transporting the product above, follow IATA Dangerous Goods Regulations, IMDG Code (International Maritime Dangerous Goods Code), and domestic transportation regulations in each country. For details, contact the transportation company to be used.

Appendix 6 Handling of Batteries and Devices with Built-in Batteries in EU Member States

This section describes the precautions for disposing of waste batteries in EU member states and exporting batteries and/or devices with built-in batteries to EU member states.

Disposal precautions

In EU member states, there is a separate collection system for waste batteries.

Dispose of batteries properly at the local community waste collection/recycling center.

The symbol shown in the following figure is printed on the batteries and packaging of batteries and devices with built-in batteries. This symbol indicates that batteries need to be disposed of separately from other wastes.



Restriction

This symbol is for EU member states only.

The symbol is specified in the new EU Battery Directive (2006/66/EC) Article 20 "Information for end-users" and Annex II.

Exportation precautions

The new EU Battery Directive (2006/66/EC) requires the following when marketing or exporting batteries and/or devices with built-in batteries to EU member states.

- To print the symbol on batteries, devices, or their packaging
- To explain the symbol in the manuals of the products

Labeling

To market or export batteries and/or devices with built-in batteries, which have no symbol, to EU member states, print the symbol shown in the figure above on the batteries, devices, or their packaging.

Explaining the symbol in the manuals

To export devices incorporating Mitsubishi programmable controller to EU member states, provide the latest manuals that include the explanation of the symbol. If no Mitsubishi manuals are provided, separately attach an explanatory note regarding the symbol to each manual of the devices.

Point

The requirements apply to batteries and/or devices with built-in batteries manufactured before the enforcement date of the new EU Battery Directive (2006/66/EC).

INDEX

B

BAT LED	16
Battery connector	17
Battery holder	17
Built-in analog I/O terminal block.	17
Built-in Ethernet communication connector	16
Built-in RS-485 communication terminal block	17

C

CARD LED	16
CPU module fixing screw hole	18

D

DIN rail mounting groove	18
DIN rail mounting hooks.	16

E

ERR LED	16
Expansion adapter connecting hooks	16
Expansion adapter connector cover	18
Expansion board connector	17
Expansion board connector cover.	16
Extension connector	17
Extension connector cover.	16

G

Genuine product certification label	18
---	----

I

Input display LED	16
Installing directly	65,68
Installing on DIN rail	65

M

Memory capacity.	25
--------------------------	----

N

Nameplate	18
Number of input/output points.	41
Number of remote I/O points	48

O

Output display LED	16
------------------------------	----

P

P.RUN LED	16
PWR LED	16

R

RD LED	16
------------------	----

RS-485 terminal resistor selector switch	17
RUN/STOP/RESET switch	17,110

S

SD LED	16
SD memory card disable switch	17
SD memory card slot.	17
SD/RD LED	16
Sink input.	84
Sink output.	93
Source input.	84
Source output.	93

T

Terminal	17
Terminal block cover.	16
Terminal block mounting screws.	17
Top cover	16



REVISIONS

Revision date	Revision	Description
October 2014	A	First edition

This manual confers no industrial property rights or any rights of any other kind, nor does it confer any patent licenses. Mitsubishi Electric Corporation cannot be held responsible for any problems involving industrial property rights which may occur as a result of using the contents noted in this manual.

©2014 MITSUBISHI ELECTRIC CORPORATION

WARRANTY

Please confirm the following product warranty details before using this product.

1. Gratis Warranty Term and Gratis Warranty Range

If any faults or defects (hereinafter "Failure") found to be the responsibility of Mitsubishi occurs during use of the product within the gratis warranty term, the product shall be repaired at no cost via the sales representative or Mitsubishi Service Company. However, if repairs are required onsite at domestic or overseas location, expenses to send an engineer will be solely at the customer's discretion. Mitsubishi shall not be held responsible for any re-commissioning, maintenance, or testing on-site that involves replacement of the failed module.

[Gratis Warranty Term]

The gratis warranty term of the product shall be for one year after the date of purchase or delivery to a designated place. Note that after manufacture and shipment from Mitsubishi, the maximum distribution period shall be six (6) months, and the longest gratis warranty term after manufacturing shall be eighteen (18) months. The gratis warranty term of repair parts shall not exceed the gratis warranty term before repairs.

[Gratis Warranty Range]

- 1) The range shall be limited to normal use within the usage state, usage methods and usage environment, etc., which follow the conditions and precautions, etc., given in the instruction manual, user's manual and caution labels on the product.
- 2) Even within the gratis warranty term, repairs shall be charged for in the following cases.
 - a) Failure occurring from inappropriate storage or handling, carelessness or negligence by the user. Failure caused by the user's hardware or software design.
 - b) Failure caused by unapproved modifications, etc., to the product by the user.
 - c) When the Mitsubishi product is assembled into a user's device, Failure that could have been avoided if functions or structures, judged as necessary in the legal safety measures the user's device is subject to or as necessary by industry standards, had been provided.
 - d) Failure that could have been avoided if consumable parts (battery, backlight, fuse, etc.) designated in the instruction manual had been correctly serviced or replaced.
 - e) Relay failure or output contact failure caused by usage beyond the specified life of contact (cycles).
 - f) Failure caused by external irresistible forces such as fires or abnormal voltages, and failure caused by force majeure such as earthquakes, lightning, wind and water damage.
 - g) Failure caused by reasons unpredictable by scientific technology standards at time of shipment from Mitsubishi.
 - h) Any other failure found not to be the responsibility of Mitsubishi or that admitted not to be so by the user.

2. Onerous repair term after discontinuation of production

- 1) Mitsubishi shall accept onerous product repairs for seven (7) years after production of the product is discontinued.
Discontinuation of production shall be notified with Mitsubishi Technical Bulletins, etc.
- 2) Product supply (including repair parts) is not available after production is discontinued.

3. Overseas service

Overseas, repairs shall be accepted by Mitsubishi's local overseas FA Center. Note that the repair conditions at each FA Center may differ.

4. Exclusion of loss in opportunity and secondary loss from warranty liability

Regardless of the gratis warranty term, Mitsubishi shall not be liable for compensation of damages caused by any cause found not to be the responsibility of Mitsubishi, loss in opportunity, lost profits incurred to the user or third person by failure of Mitsubishi products, special damages and secondary damages whether foreseeable or not, compensation for accidents, and compensation for damages to products other than Mitsubishi products, replacement by the user, maintenance of on-site equipment, start-up test run and other tasks.

5. Changes in product specifications

The specifications given in the catalogs, manuals or technical documents are subject to change without prior notice.

6. Product application

- 1) In using the Mitsubishi MELSEC programmable controller, the usage conditions shall be that the application will not lead to a major accident even if any problem or fault should occur in the programmable controller device, and that backup and fail-safe functions are systematically provided outside of the device for any problem or fault.
- 2) The Mitsubishi programmable controller has been designed and manufactured for applications in general industries, etc. Thus, applications in which the public could be affected such as in nuclear power plants and other power plants operated by respective power companies, and applications in which a special quality assurance system is required, such as for railway companies or public service purposes shall be excluded from the programmable controller applications.
In addition, applications in which human life or property that could be greatly affected, such as in aircraft, medical applications, incineration and fuel devices, manned transportation, equipment for recreation and amusement, and safety devices, shall also be excluded from the programmable controller range of applications.
However, in certain cases, some applications may be possible, providing the user consults their local Mitsubishi representative outlining the special requirements of the project, and providing that all parties concerned agree to the special circumstances, solely at the user's discretion.

TRADEMARKS

Microsoft® and Windows® are either registered trademarks or trademarks of Microsoft Corporation in the United States and/or other countries.

Ethernet is a trademark of Xerox Corporation.

Anywire is a registered trademark of the Anywire Corporation.

MODBUS® is a registered trademark of Schneider Electric SA.

Phillips is a registered trademark of Phillips Screw Company.

SD logo and SDHC logo are trademarks or registered trademarks of SD-3C, LLC.



The company name and the product name to be described in this manual are the registered trademarks or trademarks of each company.

Manual number: JY997D55301A

Model: FX5U-U-HW-E

Model code: 09R536

When exported from Japan, this manual does not require application to the Ministry of Economy, Trade and Industry for service transaction permission.

mitsubishi electric corporation

HEAD OFFICE: TOKYO BUILDING, 2-7-3 MARUNOUCHI, CHIYODA-KU, TOKYO 100-8310, JAPAN
HIMEJI WORKS: 840, CHIYODA MACHI, HIMEJI, JAPAN

Specifications are subject to change without notice.