

R88A-MCW151-□

1.5 axis motion controller

Advanced motion made perfectly intuitive

- Connects directly to the Sigma-II series drive
- Controls 1 real axis, 1 virtual axis and a configurable third axis
- Provides an additional encoder input/output to the servo drive
- Simple to develop and modify using BASIC
- Built-in local I/O for easy operation
- Provides two additional hardware registration inputs to the drive
- Electronic CAM profiles and axes synchronization
- Multi-tasking functionality
- Friendly and powerful Windows-based software
- Network connectivity via HostLink or DeviceNet
- Supports HMI connection without the need of a PLC



System configuration

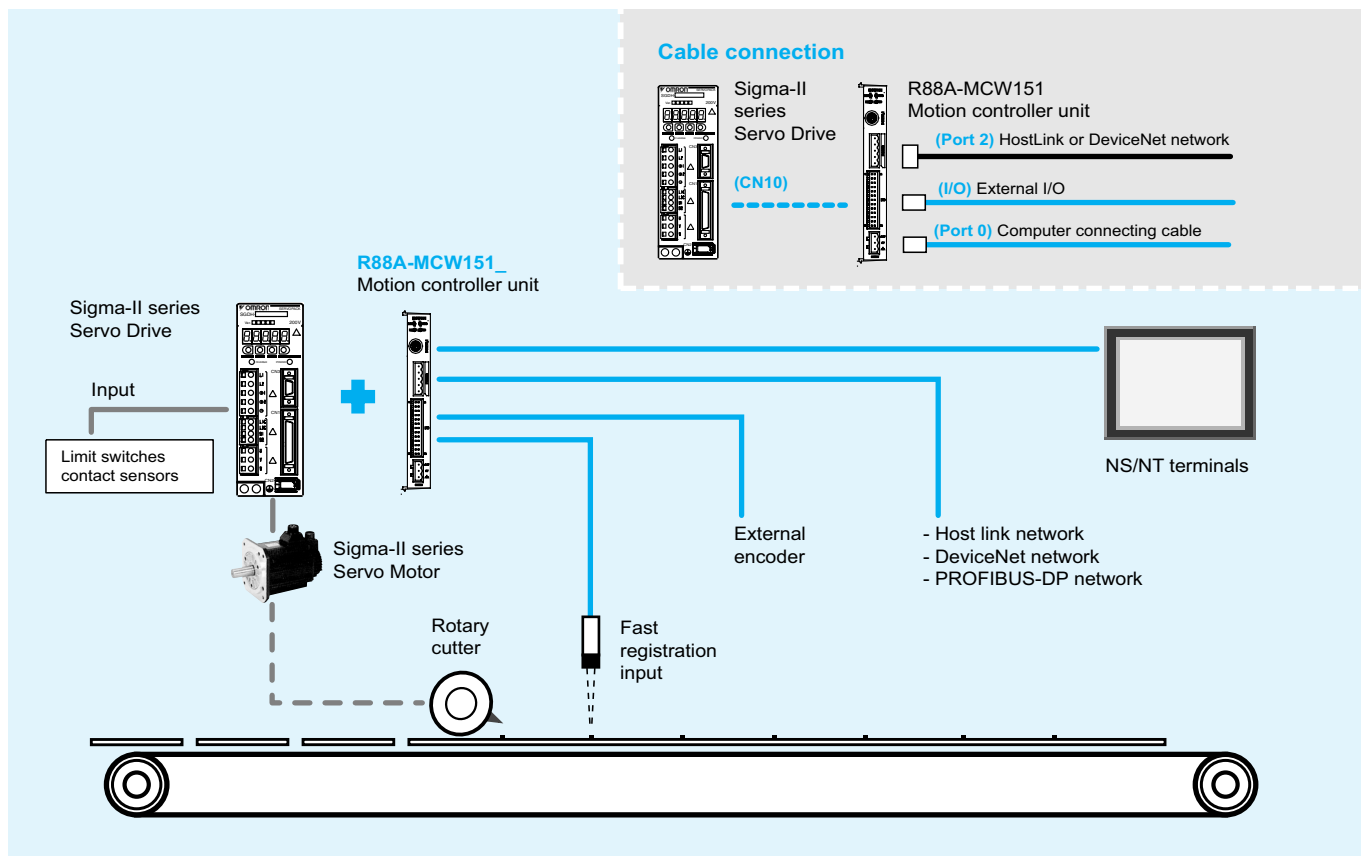

Specifications

General specifications

Item	Details	
Type	R88A-MCW151-E, R88A-MCW151-DRT-E	
Applicable servo drive	SGDH-□□□E models (software version 14 or later)	
Installation method	Mounted on the SGDh servo drive side: CN10.	
Basic specifications	Power supply method	24 VDC (supplied from external power supply) 5 VDC (supplied from the servo drive control power supply)
	Power consumption	4.0 W
	External dimensions	20x142x128 mm (HxWxD)
	Approx. mass	200 g
	Current consumption	170 mA for 24 VDC
	Output power supply	5 VDC, maximum 160 mA (to external encoder)
Environment	Operating temperature	0 ... +55 °C
	Storage temperature	-20 ... +75 °C
	Operating and storage humidity	90% RH max. (no condensation)
	Vibration resistance	0.5 G (4.9 m/s ²)
	Shock resistance	2 G (19.6 m/s ²)
Functional specifications	Number of axes	- 1 controlled servo drive axis - 1 master axis, encoder output axis or virtual axis - 1 virtual axis
	Servo loop cycle	Selectable to 0.5 ms or 1.0 ms.
	Registration inputs	2x MCW151 unit for encoder input axis 1x Sigma-II servo drive axis
	Measurement units	User definable
Programming	Programming language	BASIC
	Number of tasks	Up to 3 tasks running simultaneously plus the command line task
	Max. number of programs	14
	Available memory for user programs	128 KB
	Data storage capacity	251 (VR) + 8000 (table)
	Saving program data, motion controller	Random access memory (RAM) and flash memory backup.
Saving program data, personal computer	Motion perfect software manages a backup on the hard disk of the personal computer.	
Motion control	Speed control	Inferred closed loop with PID, output speed and speed feed forward gains Speed reference (open loop) Possible torque limit operation
	Torque control	Torque reference (open loop) Possible speed limit operation
	Control switch	Speed / torque control switching during operation
	Positioning operations	Linear interpolation Circular interpolation CAM profile movement Electronic gearbox link Linked CAM profile movement Linked move for any two axes Adding axes
	Acceleration/deceleration curves	Trapezoidal or S-curve
Servo drive access	Motion control	Speed control Torque control Position feedback Driver enable Driver print registration
	Monitoring	Driver alarm and warning status General driver status Driver digital input Driver analogue input Driver limit switches
	General control	Driver alarm reset Driver reset
	Parameter access	Read and write Pn parameters Read Un parameters
External I/O	Encoder input	Line receiver input; maximum response frequency: 1500 kHz pulses (before multiplication) Pulse multiplication: x4
	Encoder output	Line receive output; maximum frequency: 500 kHz pulses Internal counts to output pulse ratio: 64:1
	Digital inputs	Total of 8 digital inputs can be wired and used for instance for limit switches, emergency stop and proximity inputs. Two inputs can be used for registration of the encoder input/output axis.
	Digital outputs	Total of 6 digital outputs can be wired and used for position dependent switching or other general purposes.
	Registration inputs	Two registration inputs can be used (simultaneously) to capture the position in hardware.
Serial communications	RS-232C	Port 0: Connection to PC (motion perfect software) Port 1: Host link master protocol Host link slave protocol General-purpose

RS-422A/485 interface specifications (R88A-MCW151-E only)

Item	Details	
Electrical characteristics	Conform to EIA RS-422A/485	
Synchronization	Start-stop synchronization (asynchronous)	
Baud rate	1200 / 2400 / 4800 / 9600 / 19200 / 38400 bps	
Transmission format	Databit length	7 or 8 bit
	Stop bit	1 or 2 bit
	Parity bit	Even/odd/none
Transmission mode	Point-to-multipoint (1:N)	
Transmission protocol	RS-422A	Host link master protocol, Host link slave protocol, ASCII general-purpose
	RS-485	ASCII general-purpose
Galvanic isolation	Yes	
Connector type	Phoenix MSTB 2.5/5-ST-5.08 (included in package).	
Communication buffers	254 bytes	
Flow control	None	
Terminator	Yes, internal 220 Ω selectable by DIP-switch SW2	
Cable length	500 m max.	

DeviceNet specifications (R88A-MCW151-DRT-E only)

Item	Details	
Communications protocol	DeviceNet	
Supported connections (communications)	Remote I/O polling messages Explicit messages Both conform to DeviceNet specifications	
Baud rate	500 kbps, 250 kbps, 125 kbps (switchable)	
Communications media	Special 5-wire cables (2 signal lines, 2 power lines, 1 shield line)	
Communications distances		
500 kbps	Network length:	100 m max. (thin cable: 100 m max.)
	Drop line length:	6 m max.
	Total drop line length:	39 m max.
250 kbps	Network length:	250 m max. (thin cable: 100 m max.)
	Drop line length:	6 m max.
	Total drop line length:	78 m max.
125 kbps	Network length:	500 m max. (thin cable: 100 m max.)
	Drop line length:	6 m max.
	Total drop line length:	156 m max.

Nomenclature

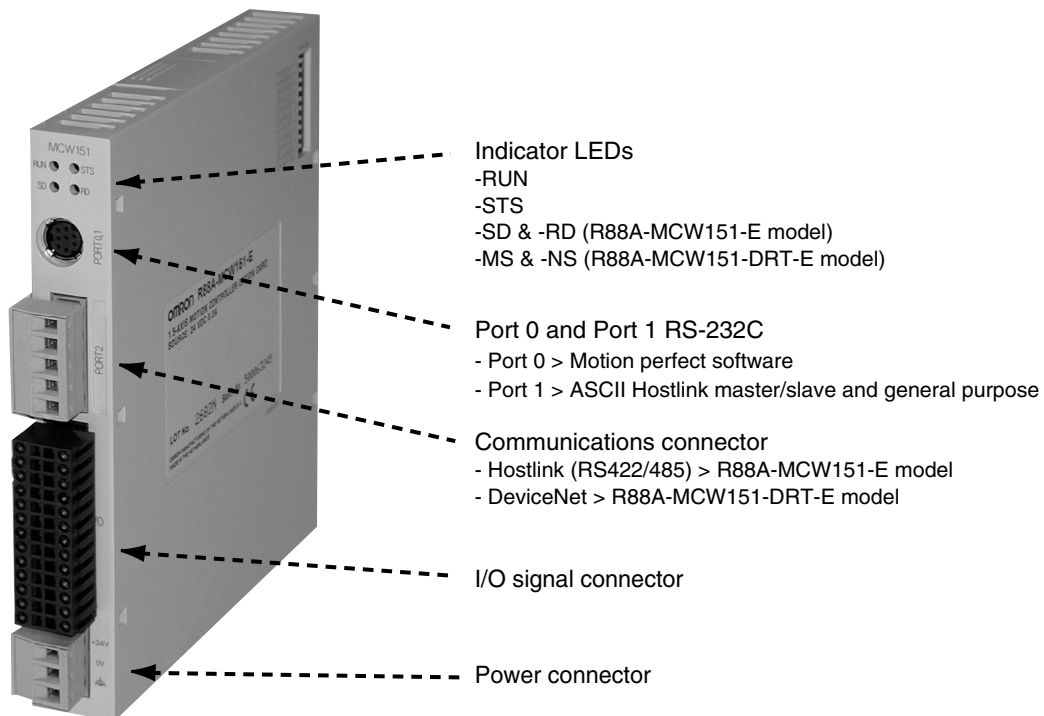

Dimensions

R88A-MCW151-(DRT)-E - 1.5 axes motion controller unit

Units: mm Approx. weight: 0.2 kg

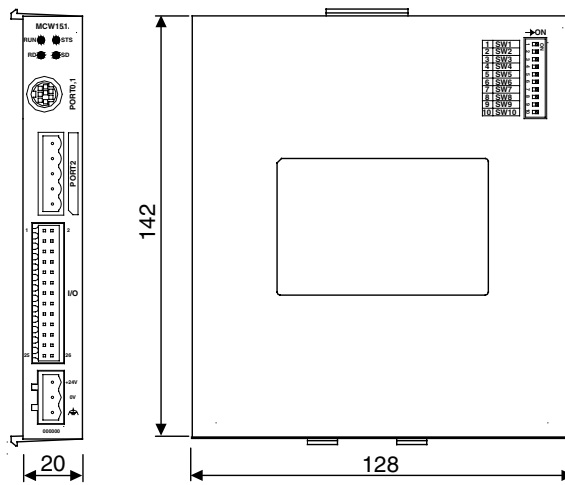

Installation

I/O connector

Connector pin arrangement

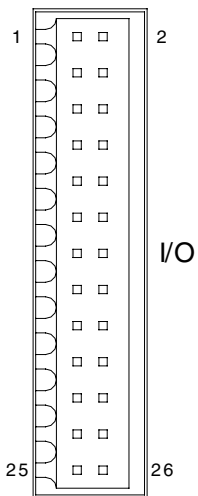

A+	1	2	A-
B+	3	4	B-
Z+	5	6	Z-
0V_ENC	7	8	5V_ENC
I0 / R0	9	10	FG
I2	11	12	I1 / R1
I4	13	14	I3
I6	15	16	I5
0V_IN	17	18	I7
O8	19	20	O9
O10	21	22	O11
O12	23	24	O13
0V_OP	25	26	24V_OP

I/O connector pin functions

Pin	Signal	
	Name	Function
1	A+	Encoder phase A+ (input / output)
2	A-	Encoder phase A- (input / output)
3	B+	Encoder phase B+ (input / output)
4	B-	Encoder phase B- (input / output)
5	Z+	Encoder phase Z+ (input / output)
6	Z-	Encoder phase Z- (input / output)
7	0V_ENC	Encoder 0V common
8	5V_ENC	Encoder 5 V power supply output
9	I0 / R0	(Registration) Input 0
10	FG	Frame ground
11	I2	Input 2
12	I1 / R1	(Registration) Input 1
13	I4	Input 4
14	I3	Input 3
15	I6	Input 6
16	I5	Input 5
17	0V_IN	Inputs 0 V common
18	I7	Input 7
19	O8	Output 8
20	O9	Output 9
21	O10	Output 10
22	O11	Output 11
23	O12	Output 12
24	O13	Output 13
25	0V_OP	Outputs 0 V common
26	24V_OP	Outputs 24 V power supply input

Power connector

The power connector is used to connect the 24 V power supply to the controller unit

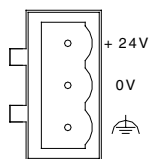

Pin	Name	Function
1	+24 V	Power supply 24 V
2	0 V	Power supply 0 V
3	FG	Frame ground

RS-232C connections (port 0 and port 1)

The controller unit has two serial RS-232C ports for communication with external devices.

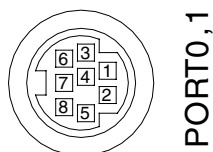

Pin	Symbol	Name	Port	Direction
1	-	Not used	-	
2	RS-1	Request to send	1	Output
3	SD-0	Send data	0	Output
4	SG-0	Signal ground	0	-
5	RD-0	Receive data	0	Input
6	SD-1	Send data	1	Output
7	SG-1	Signal ground	1	-
8	RD-1	Receive data	1	Input

RS-422A/485 connections (R88A-MCW151-E only)

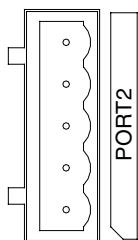

Pin	Symbol	Name	Port	Direction
1	RD-	Receive data (-)	2	Input
2	RD+	Receive data (+)	2	Input
3	FG	Frame ground	2	-
4	SD-	Send data (-)	2	Output
5	SD+	Send data (+)	2	Output

DeviceNet connections (R88A-MCW151-DRT-E only)

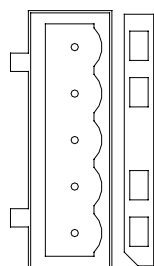

Pin	Symbol	Signal	Color of cable
1	V+	Power line, positive voltage	Red
2	CAN-H	Communications line, high	White
3	Shield	Shield	-
4	CAN-L	Communications line, low	Blue
5	V-	Power line, negative voltage	Black

Ordering information

System configuration

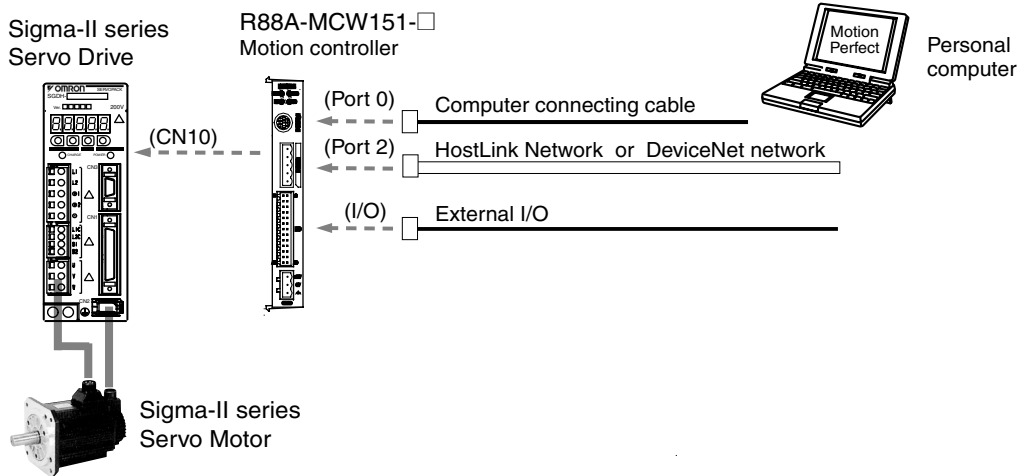

Motion controller unit

Name	Model
1.5 axis advanced motion controller with Host Link interface	R88A-MCW151-E
1.5 axis advanced motion controller with DeviceNet interface	R88A-MCW151-DRT-E

PROFIBUS connectivity

Name	Model
PROFIBUS-DP module interface for R88A-MCW151-E motion controllers	PRT1-SCU11

Serial cables (for port 0, 1)

Name	Model
Programing cable, 2 m. (Port 0)	R88A-CCM002P4-E
Splitter cable, 1 m (Port 0 & 1). Combined with R88A-CCM002P4-E cable allows using motion perfect and a general purpose application.(e.g. terminal)	R88A-CCM001P5-E

Connectors

Specification	Model
I/O connector (Included in package)	B2L 3.5/26 SN SW (Weidmüller)
Power connector (Included in package)	MSTB 2.5/3-ST-5.08 (Phoenix)
Port 2 connector (Included in package)	MSTB 2.5/5-ST-5.08 (Phoenix)

Note: For a complete view of DeviceNet network accessories, refer to automation systems catalogue or contact your OMRON representative.

Computer software

Specifications	Model
Motion perfect	MOTION TOOLS CD
EDS file	

Servo system

Note: Refer to the servo systems section for more information

ALL DIMENSIONS SHOWN ARE IN MILLIMETERS.
To convert millimeters into inches, multiply by 0.03937. To convert grams into ounces, multiply by 0.03527.