

MP2200 - MECHATROLINK-II

Motion controller

Stand-alone solution for advanced motion control

- Up to 256 axes controlled with minimum wiring
- Self configuration of nodes for an easy setup
- DeviceNet, PROFIBUS and ethernet network interfaces provide easy connectivity to any system
- Supports position, speed and torque control
- Electronic CAM profiles and axes synchronization
- The high-speed bus MECHATROLINK-II is specially designed for motion control
- Support for I/Os and pulse inputs locally and over the network
- Access to the complete system from one point.



System configuration

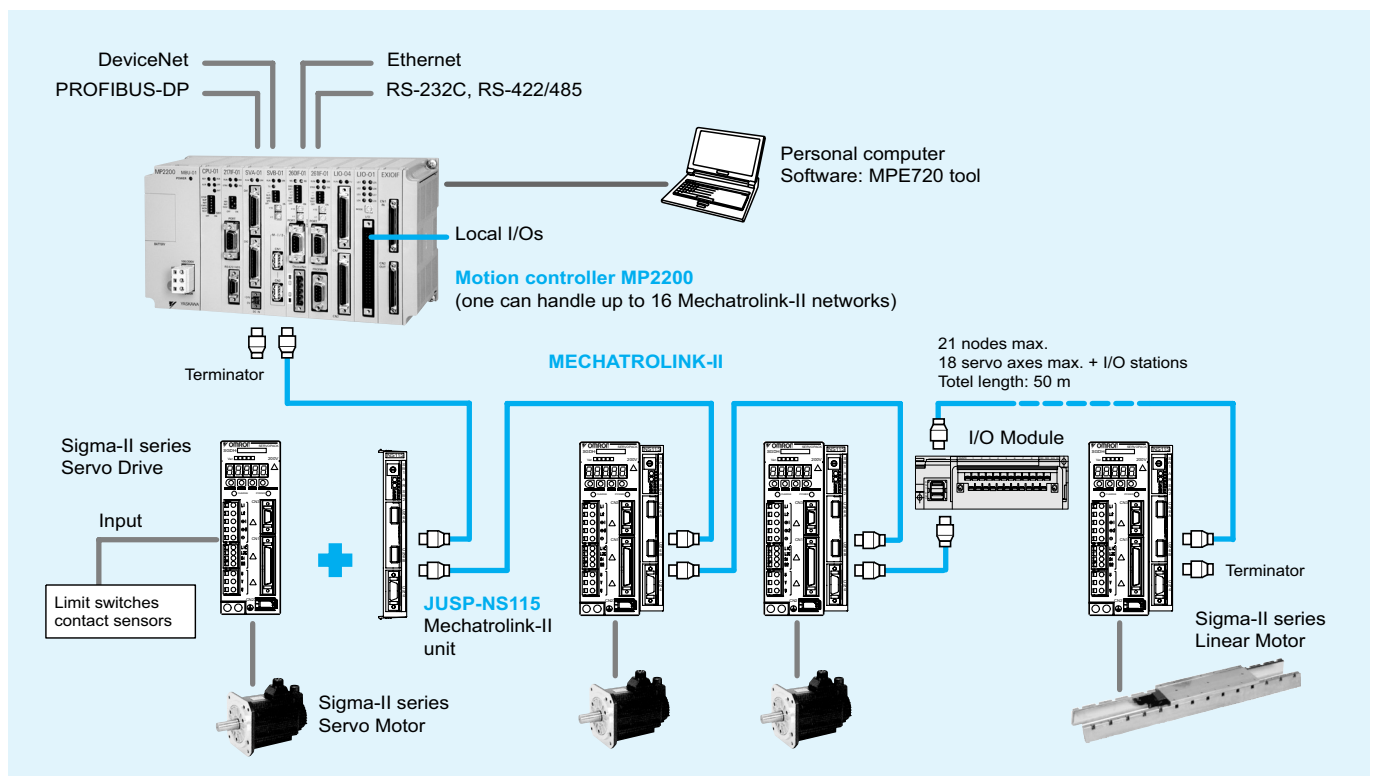

Specifications

General specifications

Hardware specifications

Items	Specifications	
Environmental conditions	Ambient operating temperature	0 to 55 °C
	Ambient storage temperature	-25 to 85 °C
	Ambient operating humidity	30% to 95% (with no condensation)
	Ambient storage humidity	5% to 95% (with no condensation)
	Pollution level	Pollution level 1 (conforming to JIS B 3501)
	Corrosive gas	There must be no combustible or corrosive gas.
	Operating altitude	2,000 m above sea level or lower
Mechanical operating conditions	Vibration resistance	Conforming to JIS B 3502: 10 to 57 Hz with single-amplitude of 0.075 mm 57 to 150 Hz with fixed acceleration of 1 G 10 sweeps each in X, Y, and Z directions (sweep time: 1 octave/min)
	Shock resistance	Conforming to JIS B 3502: Peak acceleration of 147 m/s ² (15 G) twice for 11 ms each in the X, Y, and Z directions
Electrical operating conditions	Noise resistance	Conforming to EN 61000-6-2, EN 55011 (Group 1, Class A)
Installation requirements	Ground	Ground to 100 Ω max.
	Cooling method	Natural cooling

Sequential function specifications

Items	Specifications
Control method	Sequence: High-speed and low-speed scan methods
Programming language	Ladder diagram: Relay circuit Text-type language: Numeric operations, logic operations, etc.
Scanning	Two scan levels: High-speed scan and low-speed scan High-speed scan time setting: 0.5 to 32 ms (integral multiple of MECHATROLINK communication cycle) Low-speed scan time setting: 2 to 300 ms (integral multiple of MECHATROLINK communication cycle)
User drawings, functions and motion programs	Startup drawings (DWG.A): 64 drawings max. up to three hierarchical drawing levels Interrupt processing drawings (DWG.I): 64 drawings max. up to three hierarchical drawing levels High-speed scan process drawings (DWG.H): 200 drawings max. up to three hierarchical drawing levels Low-speed scan process drawings (DWG.L): 500 drawings max. up to three hierarchical drawing levels Number of steps: Up to 1,000 steps per drawing User functions: Up to 500 functions Motion programs: Up to 256 Revision history of drawings and motion programs Security function for drawings and motion programs
Data memory	Common data (M) registers: 64 Kwords System (S) registers: 8 Kwords Drawing local (D) registers: Up to 16 Kwords per drawing Drawing constant (#) registers: Up to 16 Kwords per drawing Input (I) registers: 5 Kwords (including internal input registers) Output (O) registers: 5 Kwords (including internal output registers) Constant (C) registers: 16 Kwords
Trace memory	Data trace: 128 Kwords (32 Kwords, 4 groups), 16 points defined
Memory backup	Program memory: Flash memory: 8 MBytes (User area: 5.5 MBytes) definition files, ladder programs, motion programs, etc. Data memory: Battery backup: 256 Kbytes, M registers, S registers, alarm history, trace data
Data types	Bit (relay): ON/OFF Integer: -32768 to +32767 Double-length integer: -2147483648 to +2147483647 Real number: ± (1.175E-38 to 3.402E+38)
Register designation method	Register number: Direct designation of register number Symbolic designation: Up to 8 alphanumeric characters (up to 200 symbols per drawing) With automatic number or symbol assignment

Motion control function specifications

Item	Specifications		
Interface	MECHATROLINK-I, MECHATROLINK-II		
Number of controlled axes/module	Up to 16 axes		
Control specifications	PTP control	Linear, rotary, and infinite-length	
	Interpolation	Up to 16 linear axes, 2 circular axes, and 3 helical axes	
	Speed reference output	Yes	
	Torque reference output	Yes	
	Phase control	Yes	
	Position control	Positioning	Yes
		External positioning	Yes
		Zero point return	Yes
		Interpolation	Yes
		Interpolation with position detection function	Yes
JOG operation		Yes	
STEP operation		Yes	
Parameter changes during motion command execution	Yes		
Reference unit	mm, inch, deg, or pulse		
Reference unit minimum setting	1, 0.1, 0.01, 0.001, 0.0001, 0.00001		
Maximum programmable value	-2147483648 to +2147483647 (signed 32-bit value)		
Speed reference unit	Reference unit/s designation: mm/s, inch/s, deg/s, pulse/s Reference unit/min. designation: mm/min, inch/min, deg/min, pulse/min Percentage designation: Percentage of rated speed		
Acceleration/deceleration type	Linear, asymmetric, S-curve, exponent		
Acceleration/deceleration reference unit	Reference unit/s ² designation: mm/s ² , inch/s ² , deg/s ² , pulse/s ² Acceleration/deceleration time constant: Time from 0 to rated speed (ms)		
Override function	Positioning: 0.01% to 327.67% by axis		
Coordinate system	Rectangular coordinates		
Zero point return	DEC1+ phase-C pulse	Yes	
	ZERO signal	Yes	
	DEC1+ ZERO signal	Yes	
	Phase-C pulse	Yes	
	Only phase-C pulse	Yes	
	POT and phase-C pulse	Yes	
	POT	Yes	
	Home limit switch and phase-C pulse	Yes	
	HOME	Yes	
	NOT and phase-C pulse	Yes	
	NOT	Yes	
	INPUT and phase-C pulse	Yes	
INPUT	Yes		
Applicable servo drives	SGDH-□□□E-OY + NS115		
Applicable frequency inverters	Varispeed V7, F7, G7 with MECHATROLINK-II interface (for inverter version support contact your OMRON sales office)		
Encoders	Incremental encoder Yaskawa absolute encoder		

MP2200 base units

Items	Specifications	Appearance
Model	JEPMC-BU2200 (MBU-01) JEPMC-BU2210 (MBU-02)	
Power supply	Input power voltage: 85 VAC to 276 VAC Current consumption: 1.5 A or less with I/O rating Inrush current: 10 A or less when completely discharged, 200 VAC input, output rating	
Motion network	Not available for the base unit	
I/O signals	Not available for the base unit	
Slot for optional modules	9 slots	
Expansion configuration	Maximum of 4 base units can be connected using the EXIOIF.	
Dimensions (mm)	130x240x108 (HxWxD)	
Weight	665 g 640 g	

CPU module (CPU-01)

Items	Specifications	Appearance
Model	JAPMC-CP2200	
Max. number of controlled axes	256 axes	
High-speed scan	0.5 ms to 32 ms (in units of 0.5 ms)	
Low-speed scan	2.0 ms to 300.0 ms (in units of 0.5 ms)	
User memory capacity	8 MB	
Weight	80 g	

Connection module between racks (EXIOIF)

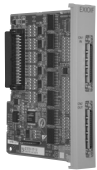
Items	Specifications	Appearance
Model	JAPMC-EX2200	
Number of expansion racks	4 racks max.	
Rack No.	Automatically identified	
Weight	70 g	

General-purpose serial communication module (217IF-01)

Items	Specifications	Appearance	
Model	JAPMC-CM2310		
Port	For RS-232C communication		For RS-422/485 communication
Interface	One port		One port (RS-422 or -485)
Connector	D-sub 9 pins (female)		MDR 14 pins (female)
Max. transmission distance	15 m		300 m
Transmission speed	76.8 kbps		76.8 kbps
Access mode	Asynchronous (start-stop synchronization)		Asynchronous (start-stop synchronization)
Communication protocols	MEMOBUS (master or slave) MELSEC, HostLink, or non-protocol		MEMOBUS (master or slave) MELSEC, HostLink, or non-protocol
Media access control method	1:1		1:1 (RS-422), 1:N (RS-485)
Transmission format (can be set)	Data bit length: 7 or 8 bits Stop bits: 1 or 2 bits Parity bits: even, odd, or none		Data bit length: 7 or 8 bits Stop bits: 1 or 2 bits Parity bits: even, odd, or none

Ethernet communication module (218IF-01)

Items	Specifications	Appearance		
Model	JAPMC-CM2300			
Port	For ethernet communication		Port	For RS-232C communication
Interface	One port (10BaseT) (RJ-45 modular jack)		Interface	One port
Max. segment length	100m		Connector	D-sub 9 pins (female)
Transmission speed	10 Mbps		Max. transmission distance	15 m
Access mode	IEEE802.3		Transmission speed	76.8 kbps
Flame format	Ethernet ver.2 (conforming to DIX)		Access mode	Asynchronous (Start-stop synchronization)
Connections	TCP/UDP/IP/ARP		Communication protocols	MEMOBUS (master or slave) MELSEC, HostLink, or non-protocol
Max. number of words in transmission	512 words (1024 bytes)		Media access control method	1:1
Communication protocols	Extended MEMOBUS, MEMOBUS, MELSEC-A, non-protocol, or MODBUS/TCP		Transmission format (can be set)	Data bit length: 7 or 8 bits Stop bits: 1 or 2 bits Parity bits: Even, odd, or none
Max. number of connections	20 stations			

DeviceNet communication module (260IF-01)

Items	Specifications	Appearance			
Model	JAPMC-CM2320				
Port	For DeviceNet communication		Port	For RS-232C communication	
Number of circuits	1		Interface	One Port	
Applicable communication	Conforms to DeviceNet master or slave - I/O transmission (polled I/O and bisstrobed I/O) - Explicit messaging		Connector	D-sub 9 pins (female)	
I/O communication	Max. number of slaves		Max. transmission distance	15m	
	Max. I/O bytes				1024 bytes, 256 bytes per node
Message Communication (only for master)	Max. number of nodes		Transmission speed	76.8kbps	
	Max. message length				256 bytes
	Executed functions				MSG-SND function
Switches on the front	Two rotary switches: Node address settings DIP switch: Settings for transmission speed and switching master or slave		Access mode	Asynchronous (start-stop synchronization)	
Indicators	2 LEDs: MS or NS		Communication protocols	MEMOBUS (master or slave) MELSEC, HostLink, or non-protocol	
Power voltage for communication	24 VDC±10% (Using the specially designed cable)		Media access control method	1:1	
Max. current consumption	Communication power: 45 mA (supplied by transmission connectors)		Transmission format (can be set)	Data bit length: 7 or 8 bits Stop bits: 1 or 2 bits Parity bits: Even, odd, or none	

PROFIBUS communication module (261IF-01)

Items	Specifications		Appearance	
Model	JAPMC-CM2330			
Port	For PROFIBUS communication	Port		For RS-232C communication
Functions	DP slave	Interface		One port
	Cyclic communication (DP standard function)	Connector		D-sub 9 pins (female)
Transmission speed	12M/6M/4M/3M/1.5M/750k/500k/187.5k/93.75k/19.2k/9.6kbps (automatic detection)	Max. transmission distance		15 m
Configuration	By PROFIBUS master			
Slave address	1 to 64	Transmission speed		76.8 kbps
I/O processing	Total capacity of IW/OW registers: 64 words Max. I/O allocation (IN and OUT each): 64 words	Access mode		Asynchronous (start-stop synchronization)
		Communication protocols		MEMOBUS (master or slave) MELSEC, HostLink, or non-protocol
Diagnostic functions	Display for status and slave status using the EWS. I/O error display for SW registers	Media access control method		1:1
		Transmission format (can be set)	Data bit length: 7 or 8 bits Stop bits: 1 or 2 bits Parity bits: Even, odd, or none	

Analogue reference motion control module (SVA-01)

Items	Specifications	Appearance
Model	JAPMC-MC2300	
Number of axes	2 axes (CN1 & CN2) analogue output and encoder input.	
Digital inputs (per axis)	6 inputs, PNP or NPN (including alarm, ready, zero and latch)	
Digital outputs (per axis)	6 outputs, (including servo_on, alarm_reset, control_mode_select and SEN)	
Encoder input (per axis)	Differential line-driver (A,/A,B,/B,Z,/Z). 4 Mpps (before multiplication).	
Analog outputs (per axis)	2 outputs ±10 V 16 bits (typically speed and torque references)	
Analog inputs (per axis)	2 inputs ±10 V 16 bits	
External supply	24 VDC (in CN3)	
LED's	RUN (green) ERR(red)	

MECHATROLINK-II motion control module (SVB-01)

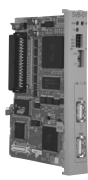
Items	Specifications	Appearance
Model	JAPMC-MC2310	
Communication circuits	1 circuit	
Communication ports	2 ports	
Terminator	External resistor (JEPMC-W6022 required)	
Transmission speed	10 Mbps	
Communication cycle	0.5 ms, 1 ms, 1.5 ms, 2 ms	
Number of connecting stations	21 stations (16 axes for servo drives and inverters) /2ms, 15 stations (15 axes for servo drives) /1.5 ms, 9 stations (9 axes for servo drives) /1 ms, 4 stations (4 axes for servo drives) /0.5 ms	
Retry function	Available with MECHATROLINK-II	
Slave function	Available with MECHATROLINK-II	
Transmission distance	See "MECHATROLINK-II repeater"	

I/O modules (LIO-01-02)

Items	Specifications	Appearance
Models	JAPMC-IO2300 (NPN output), JAPMC-IO2301 (PNP output)	
Digital I/O		
Input signals	16 points (all connected) and 24 VDC±20%, 5 mA (TYP) Sink mode or source mode input and photocoupler isolation Min. ON voltage/current: 15 V/1.6 mA Max. OFF voltage/current: 5 V/1.0 mA Max. response time: OFF→ON 1 ms and ON→OFF 1 ms Interruption (DI-00): DI-00 can be used for interruptions. If an interruption is enabled, the interrupt drawing is started when DI-00 is set to ON. Pulse latch (DI-01): DI-01 can be used for pulse latching. If pulse latching is enabled, the pulse counter is latched when DI-01 is set to ON.	
Output signals	16 points (all connected) and 24 VDC±20%, 100 mA max. Open collector: Sink mode output (LIO-01 module) Source mode output (LIO-02 module) Photocoupler isolation and max. OFF current: 0.1 mA Max. response time: OFF→ON 1 ms and ON→OFF 1 ms Output protection: Fuse (for protection against fires caused by an overcurrent when outputting after a short circuit occurred) If circuit protection is required, provide a fuse for each output circuit.	
Pulse input		
Number of channels	1 (phase A, B, or Z input)	
Input circuit	Phase A/B: 5 V differential inputs, no insulation, and max. frequency 4 MHz Phase Z: 5 V/12 V photocoupler inputs and max. frequency 500 kHz	
Input method	A/B (1, 2, or 4 multipliers), sign (1 or 2 multipliers), UP/DOWN (1 or 2 multipliers)	
Latch input	Pulse latch with phase Z or DI-01 Min. response time: 5 µs when input with phase Z; 60 µs when input with DI-01	
Others	Coincident detection; preset and clear functions for counter values	

I/O modules (LIO-04)

Items	Specifications	Appearance
Model	JAPMC-IO2303	
Input signals	<p>32 points (8 points common) and 24 VDC±20%, 5 mA (TYP) Sink mode or source mode input and photocoupler isolation Min. ON voltage/current: 15 V/1.6 mA Max. OFF voltage/current: 5 V/1.0 mA Max. response time: OFF→ON 0.5 ms and ON→OFF 0.5 ms Interruption (DI-00, DI-01, DI-16, DI-17): DI-00, DI-01, DI-16, and DI-17 can be used for interruptions. If an interruption is enabled, the interrupt drawing is started when DI-00, DI-01, DI-16, or DI-17 is set to ON. Note: See right for the derating conditions</p>	
Output signals	<p>32 points (8 points common) and 24 VDC±20%, 100 mA max. Open collector: Sink mode output (NPN) and photocoupler isolation Max. OFF current: 0.1 mA Max. response time: OFF→ON 0.5 ms and ON→OFF 1 ms Output protection: Fuse (for protection against fires caused by an overcurrent when outputting after a short-circuit occurred) If circuit protection is required, provide a fuse for each output circuit.</p>	

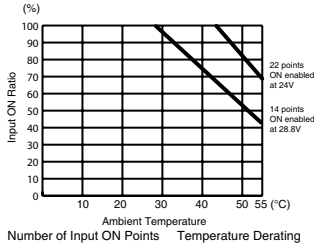

MECHATROLINK-II, 64 point I/O module (IO2310)

Items	Specifications	Appearance
Model	JEPMC-IO2310	
I/O signals	<p>Input: 64 points, 24 VDC, 5mA, sink/source mode input Output: 64 points, 24 VDC, 50mA when all points ON, (The Max. rating is 100 mA per point) sink mode output (NPN) Signal connection method: Connector (FCN360 series)</p>	
Module power supply	<p>24 VDC (20.4 V to 28.8 V) Rated current: 0.5 A Inrush current: 1 A</p>	
Weight	590 g	

MECHATROLINK-II, counter module (PL2900)

Items	Specifications	Appearance
Model	JEPMC-PL2900	
Number of input channels	2	
Functions	Pulse counter, notch output, registration input	
Pulse input method	Sign (1/2 multipliers), A/B (1/2/4 multipliers), UP/DOWN (1/2 multipliers)	
Max. counter speed	1200 kpps (4 multipliers)	
Pulse input voltage	3/5/12/24 VDC	
External power supply	24 VDC, 120 mA or less	
Weight	300 g	

MECHATROLINK-II, pulse output module (PL2910)

Items	Specifications	Appearance
Model	JEPMC-PL2910	
Number of output channels	2	
Functions	Pulse positioning, JOG run, zero-point return	
Pulse output method	CW, CCW pulse, sign	
Max. output speed	500 kpps	
Pulse output voltage	5 VDC	
Pulse interface circuit	Open collector output 5 VDC, 10 mA/circuit	
External control signal	Digital input: 8 points/module, 5 VDC x 4 points, 24 VDC x 4 points Digital output: 6 points/module, 5 VDC x 4 points, 24 VDC x 2 points	
Weight	300 g	

MECHATROLINK-II, analog input module (AN2900)

Items	Specifications	Appearance
Model	JEPMC-AN2900	
Number of input channels	4	
Input voltage range	-10 V to +10 V	
Input impedance	1 MΩ min.	
Data format	Binary, -32000 to +32000	
Input delay time	4ms max.	
Error	± 0.5% F.S. (at 25 °C), ± 1.0% F.S. (at 0 °C to 60 °C)	
External power supply	24 VDC (20.4 VDC to 26.4 VDC), 120 mA max.	
Weight	300 g	

MECHATROLINK-II, analog output module (AN2910)

Items	Specifications	Appearance
Model	JEPMC-AN2910	
Number of output channels	2	
Output voltage range	-10 V to +10 V	
Max. allowable load current	± 5 mA (2 kΩ)	
Data format	Binary, -32000 to +32000	
Output delay time	1 ms	
Error	± 0.2% F.S. (at 25 °C), ± 0.5% F.S. (at 0 °C to 60 °C)	
External power supply	24VDC (20.4 VDC to 26.4 VDC), 120mA max.	
Weight	300 g	

MECHATROLINK-II repeater

Items	Specifications	Appearance
Model	JEPMC-REP2000	
Communication type	MECHATROLINK-II	
Cable length	Between controller and repeater: 50 m., after repeater: 50 m	
Max. connected stations	Total stations on both sides of repeater: 30 (limited to the max. number of connectable stations of the controller (e.g., 21 stations for the MP2300 series))	
Restrictions	Between controller and repeater - Total cable length ≤ 30m: 15 stations max. including I/O and servo, etc. - 30m < total cable length ≤ 50m: 14 stations max. including I/O and servo, etc. After repeater: - Total cable length ≤ 30m: 16 stations max. including I/O and servo, etc. - 30m < total cable length ≤ 50m: 15 stations max. including I/O and servo, etc.	
Power supply	24VDC, 100mA	
Weight	340 g	
Dimensions (mm)	30x160x77 (HxWxD)	

MECHATROLINK-II servo drive interface unit

Item	Details		
Type	JUSP-NS115		
Applicable servo drive	SGDH-□□□□E models (version 38 or later)		
Installation method	Mounted on the SGDH servo drive side: CN10.		
Basic specifications	Power supply method	Supplied from the servo drive control power supply.	
	Power consumption	2 W	
MECHATROLINK-II communications	Baud rate/transmission cycle	10 Mbps / 1 ms or more. MECHATROLINK-II communications	
Command format	Operation specification	Positioning using MECHATROLINK-I/II communications.	
	Reference input	MECHATROLINK-I/II communications Commands: position, speed, torque, parameter read/write, monitor output	
Position control functions	Acceleration/deceleration method	Linear first/second-step, asymmetric, exponential, S-curve	
	Fully closed control	Position control with fully closed feedback is possible.	
Fully closed system specifications	Encoder pulse output in the servo drive	5 V differential line-driver output (complies with EIA Standard RS-422A)	
	Fully closed encoder pulse signal	A quad B line-driver	
	Maximum receivable frequency for servo drive	1 Mpps	
	Power supply for fully closed encoder	To be prepared by customer.	
Input signals in the servo drive	Signal allocation changes possible	Forward/reverse run prohibited, zero point return deceleration LS External latch signals 1, 2, 3 Forward/reverse torque control	
Internal functions	Position data latch function	Position data latching is possible using phase C, and external signals 1, 2, 3	
	Protection	Parameters damage, parameter setting errors, communications errors, WDT errors, fully closed encoder detecting disconnection	
	LED indicators	A: Alarm, R: MECHATROLINK-I/II communicating	

MECHATROLINK-II, frequency inverter interface units

Item	Details	
Type	SI-T/V7	SI-T
Applicable inverter	CIMR-V7 / 3G3-MV (firmware 5740 or newer)	CIMR-G7 / CIMR-F7 (firmware 656x/for G7 / 4011 or newer for F7)
	Contact your OMRON sales office for information about firmware compatibility	
Installation method	Mounted on the inverter	
Power supply	Supplied from the inverter	
MECHATROLINK-II communications	10 MHz, 0.5 ms to 8 ms for MECHATROLINK-II	
Operation	Read and write registers, read monitors, inverter operation, speed reference, torque reference (G7/F7 only).	
Inputs and outputs	The inputs and outputs in the inverter can be read and set by the MLII master	
Connectors	ML-II bus connector. DPRAM connector for the inverter	
Switches	Rotary switch for ML-II address (low byte) Dip switch for: ML-II address (high bit). ML-II/ML-I selection. 17 byte/32 byte data length selection.	

Dimensions

MP2200 basic unit

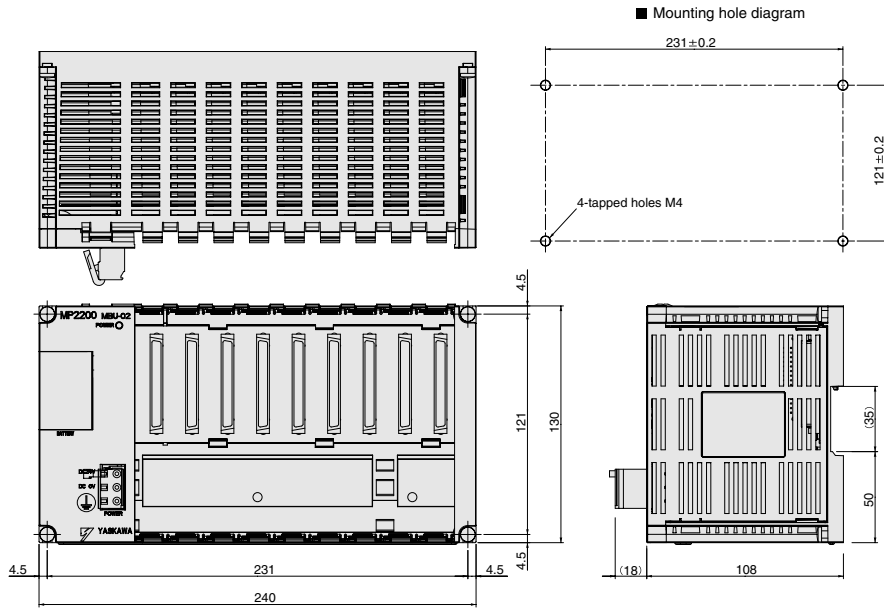

IO2310 I/O module

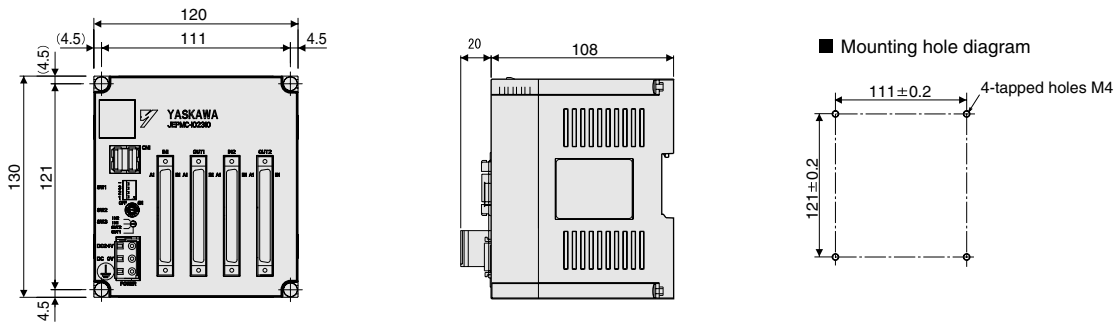

I/O modules PL2900, PL2910, AN2900, AN2910

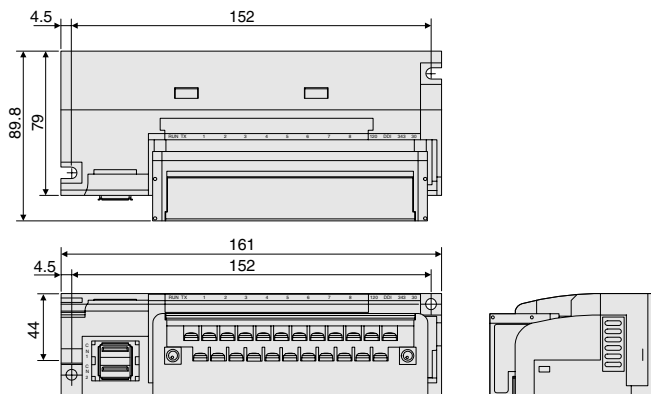

MECHATROLINK-II servo drive interface unit

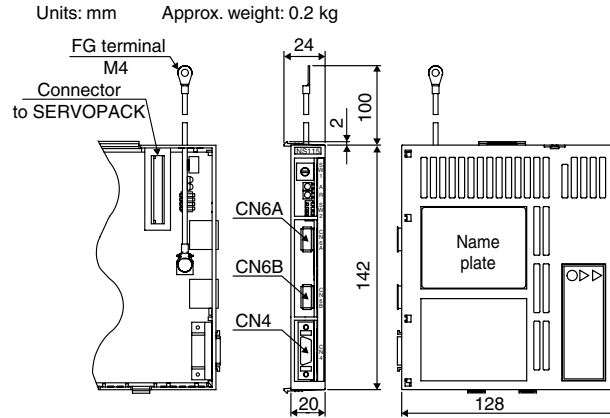

Ordering information

MP2200 - motion controller base unit

Name	Model name	Model
MP2200 base unit, 100 VAC/200 VAC input base unit	MBU-01	JEPMC-BU2200
MP2200 base unit, 24 VDC input base unit	MBU-02	JEPMC-BU2210

MP2200 - CPU module

Name	Model name	Model
CPU for MP2200	CPU-01	JAPMC-CP2200

MP2200 - motion control modules

Name	Model name	Model
Analogue reference motion control module (2 axes)	SVA-01	JAPMC-MC2300
1 channel for MECHATROLINK-II communication	SVB-01	JAPMC-MC2310

MP2200 - communication modules

Name	Model name	Model
General-purpose serial communication module (RS-232C / RS422 communication)	217IF-01	JAPMC-CM2310
Ethernet communication module (RS-232C / ethernet communication)	218IF-01	JAPMC-CM2300
DeviceNet communication module (RS-232C / DeviceNet communication)	260IF-01	JAPMC-CM2320
PROFIBUS communication module (RS-232C / PROFIBUS communication)	261IF-01	JAPMC-CM2330

MP2200 - I/O and expansion modules

Name	Model name	Model
16-point input, 16-point output (sink mode output / NPN), and 1-point pulse input	LIO-01	JAPMC-IO2300
16-point input, 16-point output (source mode output / PNP), and 1-point pulse input	LIO-02	JAPMC-IO2301
32-point input and 32-point output	LIO-04	JAPMC-IO2303
Expansion interface for MP2200	EXIOIF	JAPMC-EX2200

MECHATROLINK-II - elated devices

Name	Remarks	Model
Distributed I/O modules	64-point input and 64-point output	JEPMC-IO2310
	Reversible counter: 2 channels	JEPMC-PL2900
	Pulse output: 2 channels	JEPMC-PL2910
	Analog input: -10 V to +10 V, 4 channels	JEPMC-AN2900
	Analog output: -10 V to +10 V, 2 channels	JEPMC-AN2910
MECHATROLINK-II cables	0.5 meter	JEPMC-W6003-A5
	1 meter	JEPMC-W6003-01
	3 meters	JEPMC-W6003-03
	5 meters	JEPMC-W6003-05
	10 meters	JEPMC-W6003-10
	20 meters	JEPMC-W6003-20
	30 meters	JEPMC-W6003-30
MECHATROLINK-II terminator	Terminating resistor	JEPMC-W6022
MECHATROLINK-II interface unit	For Sigma-II series servo drives (firmware version 38 or later)	JUSP-NS115
	For Varispeed V7 inverter (for inverter's version supported contact your OMRON sales office)	SI-T/V7
MECHATROLINK-II repeater	For Varispeed F7, G7 inverter (for inverter's version supported contact your OMRON sales office)	SI-T
	MECHATROLINK-II repeater	JEPMC-REP2000

I/O cables

	Remarks	Length m	Model
I/O cable for LIO-01, 02	With connector on the LIO-01, -02 side	0.5	JEPMC-W2061-A5
		1.0	JEPMC-W2061-01
		3.0	JEPMC-W2061-03
I/O cable for LIO-04	With connector on the LIO-04 side	0.5	JEPMC-W6060-05
		1.0	JEPMC-W6060-10
		3.0	JEPMC-W6060-30
I/O cable for IO2310	With connector on the IO2310 side	0.5	JEPMC-W5410-05
		1.0	JEPMC-W5410-10
		3.0	JEPMC-W5410-30
EXIOIF cable	With connector on both sides	0.5	JEPMC-W2091-A5
		1.0	JEPMC-W2091-01
		3.0	JEPMC-W2091-2A5

Accessories

Name	Model
Battery ER3V 3.6V	JZSP-BA01
Empty slot cover	JEPMC-OP2300
Brackets for DIN rail	JEPMC-OP300

Computer software

Specifications	Model
Programming software support from system design to maintenance. Intuitive ladder programming and editing functions. CAM data generation. Windows-based (Windows 95/98/NT4.0/2000/XP)	CPMC-MPE720

Servo system

Note: Refer to servo systems section for detailed information

Frequency inverters

Note: Refer to frequency inverters section for detailed information

ALL DIMENSIONS SHOWN ARE IN MILLIMETERS.

To convert millimeters into inches, multiply by 0.03937. To convert grams into ounces, multiply by 0.03527.